



Program  
on  
Improved  
Seismic  
Safety  
Provisions

*Of the National Institute of Building Sciences*

**1997 Edition**

**NEHRP RECOMMENDED PROVISIONS  
FOR SEISMIC REGULATIONS  
FOR NEW BUILDINGS  
AND OTHER STRUCTURES**

**Part 1: Provisions (FEMA 302)**

The **Building Seismic Safety Council (BSSC)** was established in 1979 under the auspices of the National Institute of Building Sciences as an entirely new type of instrument for dealing with the complex regulatory, technical, social, and economic issues involved in developing and promulgating building earthquake hazard mitigation regulatory provisions that are national in scope. By bringing together in the BSSC all of the needed expertise and all relevant public and private interests, it was believed that issues related to the seismic safety of the built environment could be resolved and jurisdictional problems overcome through authoritative guidance and assistance backed by a broad consensus.

The BSSC is an independent, voluntary membership body representing a wide variety of building community interests. Its fundamental purpose is to enhance public safety by providing a national forum that fosters improved seismic safety provisions for use by the building community in the planning, design, construction, regulation, and utilization of buildings.

To fulfill its purpose, the BSSC: (1) promotes the development of seismic safety provisions suitable for use throughout the United States; (2) recommends, encourages, and promotes the adoption of appropriate seismic safety provisions in voluntary standards and model codes; (3) assesses progress in the implementation of such provisions by federal, state, and local regulatory and construction agencies; (4) identifies opportunities for improving seismic safety regulations and practices and encourages public and private organizations to effect such improvements; (5) promotes the development of training and educational courses and materials for use by design professionals, builders, building regulatory officials, elected officials, industry representatives, other members of the building community, and the public; (6) advises government bodies on their programs of research, development, and implementation; and (7) periodically reviews and evaluates research findings, practices, and experience and makes recommendations for incorporation into seismic design practices.

See Appendix E of the *Commentary* volume for a full description of BSSC activities.

#### **BOARD OF DIRECTION: 1997**

<b>Chairman</b>	Eugene Zeller, City of Long Beach, California
<b>Vice Chairman</b>	William W. Stewart, Stewart-Scholberg Architects, Clayton, Missouri (representing the American Institute of Architects)
<b>Secretary</b>	Mark B. Hogan, National Concrete Masonry Association, Herndon, Virginia
<b>Ex-Officio</b>	James E. Beavers, James E. Beavers Consultants, Oak Ridge, Tennessee
<b>Members</b>	Eugene Cole, Carmichael, California (representing the Structural Engineers Association of California); S. K. Ghosh, Portland Cement Association, Skokie, Illinois; Nestor Iwankiw, American Institute of Steel Construction, Chicago, Illinois; Gerald H. Jones, Kansas City, Missouri (representing the National Institute of Building Sciences); Joseph Nicoletti, URS/John A. Blume and Associates, San Francisco, California (representing the Earthquake Engineering Research Institute); Jack Prosek, Turner Construction Company, San Francisco, California (representing the Associated General Contractors of America); W. Lee Shoemaker, Metal Building Manufacturers Association, Cleveland, Ohio; John C. Theiss, Theiss Engineers, Inc., St. Louis, Missouri (representing the American Society of Civil Engineers); Charles Thornton, Thornton-Tomasetti Engineers, New York, New York (representing the Applied Technology Council); David P. Tyree, American Forest and Paper Association, Colorado Springs, Colorado; David Wismer, Department of Licenses and Inspections, Philadelphia, Pennsylvania (representing the Building Officials and Code Administrators International); Richard Wright, National Institute of Standards and Technology, Gaithersburg, Maryland (representing the Interagency Committee for Seismic Safety in Construction)
<b>BSSC Staff</b>	James R. Smith, Executive Director; Claret M. Heider, Technical Writer-Editor/Program Manager; Thomas Hollenbach, Deputy Executive; Lee Lawrence Anderson, Director, Special Projects; Mary Marshall, Administrative Assistant; Patricia Blasi, Administrative Assistant

*BSSC Program on Improved Seismic Safety Provisions*

# **NEHRP RECOMMENDED PROVISIONS**

**(National Earthquake Hazards Reduction Program)**

## **FOR SEISMIC REGULATIONS**

### **FOR NEW BUILDINGS AND**

### **OTHER STRUCTURES**

**1997 EDITION**

**Part 1: PROVISIONS**

**(FEMA 302)**

**Prepared by the  
Building Seismic Safety Council  
for the  
Federal Emergency Management Agency**

**BUILDING SEISMIC SAFETY COUNCIL  
Washington, D.C.  
1997**

NOTICE: Any opinions, findings, conclusions, or recommendations expressed in this publication do not necessarily reflect the views of the Federal Emergency Management Agency. Additionally, neither FEMA nor any of its employees make any warranty, expressed or implied, nor assume any legal liability or responsibility for the accuracy, completeness, or usefulness of any information, product, or process included in this publication.

This report was prepared under Contract EMW-C-4536 between the Federal Emergency Management Agency and the National Institute of Building Sciences.

Building Seismic Safety Council activities and products are described at the end of this report. For further information, contact the Building Seismic Safety Council, 1090 Vermont, Avenue, N.W., Suite 700, Washington, D.C. 20005; phone 202-289-7800; fax 202-289-1092; e-mail [bssc@nibs.org](mailto:bssc@nibs.org). Copies of this report may be obtained by contacting the FEMA Publication Distribution Facility at 1-800-480-2520.

## PREFACE

One of the primary goals of the Federal Emergency Management Agency (FEMA) and the National Earthquake Hazards Reduction Program (NEHRP) is to encourage design and building practices that address the earthquake hazard and minimize the resulting damage. Publication of the 1997 *NEHRP Recommended Provisions for Seismic Regulation of New Buildings and Other Structures* represents a significant milestone in the continuing FEMA-sponsored effort to improve the seismic safety of new structures in this country. Its publication marks the fourth in a planned updating of both the *Provisions* documents and several complementary publications. As in the case of the earlier editions of the *Provisions* (1985, 1988, 1991, and 1994), FEMA is proud to have been a participant in the Building Seismic Safety Council project and encourages widespread dissemination and voluntary use of this consensus resource document.

The 1997 *Provisions* contains several major changes that have truly made this a milestone document. Probably the most significant change is the adoption of new spectral response seismic design maps reflecting seismic hazard maps recently completed by the U.S. Geological Survey. The new maps and accompanying design procedure were developed by the BSSC Seismic Design Procedures Group in conjunction with Technical Subcommittee 2 of the Provisions Update Committee, and FEMA is grateful for the hard work of all involved. A second significant change is the improvement of design procedures for high-seismic, near-source areas, and FEMA wishes to thank those members of the Structural Engineers Association of California who devoted considerable time and energy to this aspect of the update process. Another change worth noting is that the steel structure design chapter now references a new consensus standard which addresses the problems highlighted by the Northridge earthquake and reflects work done in a FEMA-funded project to resolve the welded steel moment resisting frame problem.

The above changes are but three of over 150 changes that were balloted by the BSSC member organizations. The number of changes considered was three times that involved in any of the earlier update efforts and is testament to the increased attention being paid to the *Provisions*. This is due in large part to the decision to use the 1997 *Provisions* as the basis for the seismic requirements in the new *International Building Code*. FEMA welcomes this increased scrutiny and the chance to work with the International Code Council.

Looking ahead, FEMA has already contracted with BSSC for and work already has begin on the update process that will lead to the 2000 *Provisions*. In addition to the normal update procedure, this project is designed to continue the *Provisions/International Building Code* cooperative effort and to permit development of a simplified design procedure for use in areas of lower seismicity.

In conclusion, FEMA wishes to express its sincere gratitude for the unstinting efforts of a large number of volunteer experts and the BSSC Board of Directors and staff who made possible the 1997 *Provisions* documents. Americans unfortunate enough to experience the earthquakes that will inevitably occur in this country in the future will owe much, perhaps even their very lives, to the contributions of these individuals to the seismic safety of buildings. Without the dedication

and hard work of these men and women, this document and all it represents with respect to earthquake risk mitigation would not have been possible.

*Federal Emergency Management Agency*

## INTRODUCTION and ACKNOWLEDGMENTS

The 1997 Edition of the *NEHRP Recommended Provisions for Seismic Regulations for New Buildings and Other Structures* is the fifth edition of the document and, like the 1985, 1988, 1991 and 1994 Editions that preceded it, has the consensus approval of the Building Seismic Safety Council membership. It represents a major product of the Council's multiyear, multitask Program on Improved Seismic Safety Provisions and is intended to continue to serve as a source document for use by any interested members of the building community. (For readers unfamiliar with the program, a detailed description of the BSSC's purpose and activities concludes the *Commentary* volume.)

In September 1994, NIBS entered into a contract with FEMA for initiation of the 39-month BSSC 1997 *Provisions* update effort. Late in 1994, the BSSC member organization representatives and alternate representatives and the BSSC Board of Direction were asked to identify individuals to serve on the 1997 Provisions Update Committee (PUC) and its Technical Subcommittees (TSs).

The 1997 PUC was constituted early in 1995, and 12 PUC Technical Subcommittees were established to address design criteria and analysis, foundations and geotechnical considerations, cast-in-place/precast concrete structures, masonry structures, steel structures, wood structures, mechanical-electrical systems and building equipment and architectural elements, quality assurance, interface with codes and standards, composite steel and concrete structures, energy dissipation and base isolation, and nonbuilding structures.

As part of this effort, the BSSC has developed a revised seismic design procedure for use by engineers and architects for inclusion in the 1997 *NEHRP Recommended Provisions*. Unlike the design procedure based on U.S. Geological Survey (USGS) peak acceleration and peak velocity-related acceleration ground motion maps developed in the 1970s and used in earlier editions of the *Provisions*, the new design procedure is based on recently revised USGS spectral response maps. The design procedure involves new design maps based on the USGS hazard maps and a process specified within the body of the *Provisions*. This task has been conducted with the cooperation of the USGS (under a Memorandum of Understanding signed by the BSSC and USGS) and under the guidance of a five-member Management Committee (MC). A Seismic Design Procedure Group (SDPG) has been responsible for developing the design procedure.

More than 200 individuals have participated in the 1997 update effort, and more than 165 substantive proposals for change were developed. A series of editorial/organizational changes also have been made. All draft TS, SDPG, and PUC proposals for change were finalized in late February 1997. In early March, the PUC Chairman presented to the BSSC Board of Direction the PUC's recommendations concerning proposals for change to be submitted to the BSSC member organizations for balloting, and the Board accepted these recommendations.

The first round of balloting concluded in early June 1997. Of the 158 items on the official ballot, only 8 did not pass; however, many comments were submitted with "no" and "yes with

reservations” votes. These comments were compiled for distribution to the PUC, which met in mid-July to review the comments, receive TS responses to the comments and recommendations for change, and formulate its recommendations concerning what items should be submitted to the BSSC member organizations for a second ballot. The PUC deliberations resulted in the decision to recommend to the BSSC Board that 28 items be included in the second ballot. The PUC Chairman subsequently presented the PUC’s recommendations to the Board, which accepted those recommendations.

The second round of balloting was completed in late October 1997. All but one proposal passed; however, a number of comments on virtually all the proposals were submitted with the ballots and were immediately compiled for consideration by the PUC. The PUC Executive Committee met in December to formulate its recommendations to the Board, and the Board subsequently accepted those recommendations. The final versions of the *Provisions* and *Commentary* volumes, including as Appendix A in the *Provisions* volume a summary of the differences between the 1994 and 1997 Editions, then were prepared and transmitted to FEMA for publication.

In presenting this 1997 Edition of the *Provisions*, the BSSC wishes to acknowledge the accomplishments of the many individuals and organizations involved over the years. The BSSC program resulting in the first four editions of the *Provisions*, the 1997 update effort, and the information development/dissemination activities conducted to stimulate use of the *Provisions* has benefitted from the expertise of hundreds of specialists, many of whom have given freely of their time over many years.

With so many volunteers participating, it is difficult to single out a given number or group for special recognition without inadvertently omitting others without whose assistance the BSSC program could not have succeeded; nevertheless, the 1997 Edition of the *Provisions* would not be complete without at least recognizing the following individuals to whom I, acting on behalf of the BSSC Board of Direction, heartily express sincerest appreciation:

- The members of the BSSC Provisions Update Committee, especially Chairman William Holmes;
- The mapping Management Committee and its Seismic Design Procedures Group, especially Chairman R. Joe Hunt;
- The members of the 12 PUC Technical Subcommittees; and
- Michael Mahoney, the FEMA Project Officer.

Appreciation also is due to the BSSC Executive Director James R. Smith and BSSC staff members Claret Heider and Thomas Hollenbach, all of whose talents and experience were crucial to conduct of the program.

At this point I, as Chairman, would like to express my personal gratitude to the members of the BSSC Board of Direction and to all those who provided advice, counsel, and encouragement during conduct of the update effort or who otherwise participated in the BSSC program that resulted in the 1997 *NEHRP Recommended Provisions*.

*Eugene Zeller, Chairman, BSSC Board of Direction*



# CONTENTS

## *NEHRP RECOMMENDED PROVISIONS FOR SEISMIC REGULATIONS FOR NEW BUILDINGS AND OTHER STRUCTURES*

1997 EDITION

### Part 1: PROVISIONS

<b>PREFACE</b> .....	<b>iii</b>
<b>INTRODUCTION and ACKNOWLEDGMENTS</b> .....	<b>v</b>
<b>Chapter 1, GENERAL PROVISIONS</b> .....	<b>1</b>
1.1 PURPOSE .....	1
1.2 SCOPE AND APPLICATION .....	1
1.2.1 Scope .....	1
1.2.2 Additions .....	2
1.2.3 Change of Use .....	2
1.2.4 Alterations .....	2
1.2.5 Alternate Materials and Alternate Means and Methods of Construction .....	2
1.3 SEISMIC USE GROUPS .....	2
1.3.1 Seismic Use Group III .....	2
1.3.2 Seismic Use Group II .....	3
1.3.3 Seismic Use Group I .....	3
1.3.4 Multiple Use .....	3
1.3.5 Seismic Use Group III Structure Access Protection .....	4
1.4 OCCUPANCY IMPORTANCE FACTOR .....	4
<b>Chapter 2, GLOSSARY AND NOTATIONS</b> .....	<b>5</b>
2.1 GLOSSARY .....	5
2.2 NOTATIONS .....	13
<b>Chapter 3, QUALITY ASSURANCE</b> .....	<b>27</b>
3.1 SCOPE .....	27
3.2 QUALITY ASSURANCE .....	27
3.2.1 Details of Quality Assurance Plan .....	28
3.2.2 Contractor Responsibility .....	28
3.3 SPECIAL INSPECTION .....	28
3.3.1 Piers, Piles, Caissons .....	28
3.3.2 Reinforcing Steel .....	28

3.3.3 Structural Concrete .....	29
3.3.4 Prestressed Concrete .....	29
3.3.5 Structural Masonry .....	29
3.3.6 Structural Steel .....	29
3.3.7 Structural Wood .....	29
3.3.8 Cold-Formed Steel Framing .....	29
3.3.9 Architectural Components .....	30
3.3.10 Mechanical and Electrical Components .....	30
3.4 TESTING .....	30
3.4.1 Reinforcing and Prestressing Steel .....	30
3.4.2 Structural Concrete .....	31
3.4.3 Structural Masonry .....	31
3.4.5 Mechanical and Electrical Equipment .....	31
3.4.6 Seismically Isolated Structures .....	31
3.5 STRUCTURAL OBSERVATIONS .....	31
3.6 REPORTING AND COMPLIANCE PROCEDURES .....	32
<b>Chapter 4, GROUND MOTION .....</b>	<b>33</b>
4.1 PROCEDURES FOR DETERMINING MAXIMUM CONSIDERED EARTHQUAKE AND DESIGN EARTHQUAKE GROUND MOTION ACCELERATIONS AND RESPONSE SPECTRA .....	33
4.1.1 Maximum Considered Earthquake Ground Motions .....	33
4.1.2 General Procedure for Determining Maximum Considered Earthquake and Design Spectral Response Accelerations: .....	33
4.1.3 Site-Specific Procedure for Determining Ground Motion Accelerations .....	39
4.2 SEISMIC DESIGN CATEGORY .....	40
4.2.1 Determination of Seismic Design Category .....	40
4.2.2 Site Limitation for Seismic Design Categories E and F .....	41
<b>Chapter 5, STRUCTURAL DESIGN CRITERIA .....</b>	<b>43</b>
5.1 REFERENCE DOCUMENT: .....	43
5.2 DESIGN BASIS .....	43
5.2.1 General .....	43
5.2.2 Basic Seismic-Force-Resisting Systems .....	43
5.2.3 Structure Configuration .....	52
5.2.4 Redundancy .....	55
5.2.5 Analysis Procedures .....	56
5.2.6 Design, Detailing Requirements, and Structural Component Load Effects .....	58
5.2.7 Combination of Load Effects .....	62
5.2.8 Deflection and Drift Limits .....	63
5.3 EQUIVALENT LATERAL FORCE PROCEDURE .....	64
5.3.1 General .....	64
5.3.2 Seismic Base Shear .....	64
5.3.3 Period Determination .....	66

5.3.4 Vertical Distribution of Seismic Forces	67
5.3.5 Horizontal Shear Distribution	68
5.3.6 Overturning	68
5.3.7 Drift Determination and <i>P</i> -Delta Effects	69
5.4 MODAL ANALYSIS PROCEDURE	71
5.4.1 General	71
5.4.2 Modeling	71
5.4.3 Modes	71
5.4.4 Modal Properties	71
5.4.5 Modal Base Shear	72
5.4.6 Modal Forces, Deflections, and Drifts	73
5.4.7 Modal Story Shears and Moments	74
5.4.8 Design Values	74
5.4.9 Horizontal Shear Distribution	75
5.4.10 Foundation Overturning	75
5.4.11 P-Delta Effects	75
5.5 SOIL-STRUCTURE INTERACTION EFFECTS	75
5.5.1 General	75
5.5.2 Equivalent Lateral Force Procedure	75
5.5.3 Modal Analysis Procedure	80

**Chapter 6, ARCHITECTURAL, MECHANICAL, AND ELECTRICAL COMPONENTS DESIGN REQUIREMENTS** ..... **83**

6.1 GENERAL	83
6.1.1 References and Standards	84
6.1.2 Component Force Transfer	85
6.1.3 Seismic Forces	86
6.1.4 Seismic Relative Displacements	87
6.1.5 Component Importance Factor	88
6.1.6 Component Anchorage	88
6.1.7 Construction Documents	89
6.2 ARCHITECTURAL COMPONENT DESIGN	90
6.2.1 General	90
6.2.2 Architectural Component Forces and Displacements	90
6.2.3 Architectural Component Deformation	91
6.2.4 Exterior Nonstructural Wall Elements and Connections	91
6.2.5 Out-of-Plane Bending	92
6.2.6 Suspended Ceilings	92
6.2.7 Access Floors	94
6.2.8 Partitions	94
6.2.9 Steel Storage Racks	94
6.3 MECHANICAL AND ELECTRICAL COMPONENT DESIGN	94
6.3.1 General	94
6.3.2 Mechanical and Electrical Component Forces and Displacements	95

6.3.3 Mechanical and Electrical Component Period . . . . .	96
6.3.4 Mechanical and Electrical Component Attachments . . . . .	96
6.3.5 Component Supports . . . . .	97
6.3.6 Component Certification . . . . .	97
6.3.7 Utility and Service Lines at Structure Interfaces . . . . .	97
6.3.8 Site-Specific Considerations . . . . .	97
6.3.9 Storage Tanks . . . . .	97
6.3.10 HVAC Ductwork . . . . .	97
6.3.11 Piping Systems . . . . .	98
6.3.12 Boilers and Pressure Vessels . . . . .	99
6.3.13 Mechanical Equipment, Attachments, and Supports . . . . .	100
6.3.14 Electrical Equipment, Attachments, and Supports: . . . . .	102
6.3.15 Alternative Seismic Qualification Methods . . . . .	103
6.3.16 Elevator Design Requirements . . . . .	103

**Chapter 7, FOUNDATION DESIGN REQUIREMENTS . . . . . 105**

7.1 GENERAL . . . . .	105
7.2 STRENGTH OF COMPONENTS AND FOUNDATIONS . . . . .	105
7.2.1 Structural Materials . . . . .	105
7.2.2 Soil Capacities . . . . .	105
7.3 SEISMIC DESIGN CATEGORIES A AND B . . . . .	105
7.4 SEISMIC DESIGN CATEGORY C . . . . .	105
7.4.1 Investigation . . . . .	105
7.4.2 Pole-Type Structures . . . . .	105
7.4.3 Foundation Ties . . . . .	106
7.4.4 Special Pile Requirements . . . . .	106
7.5 SEISMIC DESIGN CATEGORIES D, E, AND F . . . . .	107
7.5.1 Investigation . . . . .	107
7.5.2 Foundation Ties . . . . .	107
7.5.3 Liquefaction Potential and Soil Strength Loss . . . . .	107
7.5.4 Special Pile Requirements . . . . .	107

**Chapter 8, STEEL STRUCTURE DESIGN REQUIREMENTS . . . . . 109**

8.1 REFERENCE DOCUMENTS . . . . .	109
8.2 SEISMIC REQUIREMENTS FOR STEEL STRUCTURES . . . . .	109
8.3 SEISMIC DESIGN CATEGORIES A, B, AND C . . . . .	109
8.4 SEISMIC DESIGN CATEGORIES D, E, AND F . . . . .	109
8.5 COLD-FORMED STEEL SEISMIC REQUIREMENTS . . . . .	109
8.5.1 Modifications to Ref. 8.4 . . . . .	110
8.5.2 Modifications to Ref. 8.5 . . . . .	110
8.6 LIGHT-FRAMED WALLS . . . . .	110
8.6.1 Boundary Members . . . . .	110
8.6.2 Connections . . . . .	110

8.6.3 Braced Bay Members .....	110
8.6.4 Diagonal Braces .....	110
8.7 SEISMIC REQUIREMENTS FOR STEEL DECK DIAPHRAGMS .....	111
8.8 STEEL CABLES .....	111

**Chapter 9, CONCRETE STRUCTURE DESIGN REQUIREMENTS ..... 113**

9.1 REFERENCE DOCUMENTS: .....	113
9.1.1 Modifications to Ref. 9-1 .....	113
9.2 BOLTS AND HEADED STUD ANCHORS IN CONCRETE .....	123
9.2.1 Load Factor Multipliers .....	123
9.2.2 Strength of Anchors .....	123
9.2.3 Strength Based on Tests .....	123
9.2.4 Strength Based on Calculations .....	123
9.3 CLASSIFICATION OF SEISMIC-FORCE-RESISTING SYSTEMS .....	129
9.3.1 Classification of Moment Frames .....	129
9.3.2 Classification of Shear Walls .....	130
9.4 SEISMIC DESIGN CATEGORY A .....	130
9.5 SEISMIC DESIGN CATEGORY B .....	131
9.5.1 Moment Frames .....	131
9.6 SEISMIC DESIGN CATEGORY C .....	131
9.6.1 Seismic-Force-Resisting Systems .....	131
9.6.2 Discontinuous Members .....	131
9.6.3 Plain Concrete .....	131
9.7 SEISMIC DESIGN CATEGORIES D, E, OR F .....	132
9.7.1 Seismic-Force-Resisting Systems .....	132
9.7.2 Frame Members Not Proportioned to Resist Forces Induced by Earthquake Motions ..	132
9.7.3 Plain Concrete .....	132

Appendix to Chapter 9, REINFORCED CONCRETE STRUCTURAL SYSTEMS COMPOSED FROM INTERCONNECTED PRECAST ELEMENTS .....	133
--	-----

**Chapter 10, STEEL AND CONCRETE STRUCTURE DESIGN REQUIREMENTS .. 137**

10.1 REFERENCE DOCUMENTS .....	137
10.2 REQUIREMENTS .....	137

**Chapter 11, MASONRY STRUCTURE DESIGN REQUIREMENTS ..... 139**

11.1 GENERAL .....	139
11.1.1 Scope .....	139
11.1.2 Reference Documents .....	139
11.1.3 Definitions .....	139
11.1.4 Notations .....	142
11.2 CONSTRUCTION REQUIREMENTS .....	144

11.2.1	General	144
11.2.2	Quality Assurance	144
11.3	GENERAL REQUIREMENTS	144
11.3.1	Scope	144
11.3.2	Empirical Masonry Design	144
11.3.3	Plain (Unreinforced) Masonry Design	144
11.3.4	Reinforced Masonry Design	144
11.3.5	Seismic Design Category A	145
11.3.6	Seismic Design Category B	145
11.3.7	Seismic Design Category C	145
11.3.8	Seismic Design Category D	146
11.3.9	Seismic Design Categories E and F	147
11.3.10	Properties of Materials	147
11.3.11	Section Properties	149
11.4	DETAILS OF REINFORCEMENT	153
11.4.1	General	153
11.4.2	Size of Reinforcement	153
11.4.3	Placement Limits for Reinforcement	153
11.4.4	Cover for Reinforcement	153
11.4.5	Development of Reinforcement	154
11.5	STRENGTH AND DEFORMATION REQUIREMENTS	156
11.5.1	General	156
11.5.2	Strength	156
11.5.3	Design Strength	156
11.5.4	Deformation Requirements	157
11.6	FLEXURE AND AXIAL LOADS	158
11.6.1	Scope	158
11.6.2	Design Requirements of Reinforced Masonry Members	158
11.6.3	Design of Plain (Unreinforced) Masonry Members	159
11.7	SHEAR	159
11.7.1	Scope	159
11.7.2	Shear Strength	160
11.7.3	Design of Reinforced Masonry Members	160
11.7.4	Design of Plain (Unreinforced) Masonry Members	162
11.8	SPECIAL REQUIREMENTS FOR BEAMS	162
11.9	SPECIAL REQUIREMENTS FOR COLUMNS	163
11.10	SPECIAL REQUIREMENTS FOR WALLS	163
11.11	SPECIAL REQUIREMENTS FOR SHEAR WALLS	164
11.11.1	Ordinary Plain Masonry Shear Walls	164
11.11.2	Detailed Plain Masonry Shear Walls	164
11.11.3	Ordinary Reinforced Masonry Shear Walls	164
11.11.4	Intermediate Reinforced Masonry Shear Walls	164
11.11.5	Special Reinforced Masonry Shear Walls	164
11.11.6	Flanged Shear Walls	165
11.11.7	Coupled Shear Walls	165

11.12 SPECIAL MOMENT FRAMES OF MASONRY .....	166
11.12.1 Calculation of Required Strength .....	166
11.12.2 Flexural Yielding .....	166
11.12.3 Reinforcement .....	166
11.12.4 Wall Frame Beams .....	166
11.12.5 Wall Frame Columns .....	167
11.12.6 Wall Frame Beam-Column Intersection .....	168
11.13 GLASS-UNIT MASONRY AND MASONRY VENEER .....	170
11.13.1 Design Lateral Forces and Displacements .....	170
11.13.2 Glass-Unit Masonry Design .....	170
11.13.3 Masonry Veneer Design .....	170

Appendix to Chapter 11, ALTERNATIVE PROVISIONS FOR THE DESIGN OF MASONRY STRUCTURES .....	171
--	-----

**Chapter 12, WOOD STRUCTURE DESIGN REQUIREMENTS ..... 173**

12.1 GENERAL .....	173
12.1.1 Scope .....	173
12.1.2 Reference Documents .....	173
12.1.3 Notations .....	174
12.2 DESIGN METHODS .....	174
12.2.1 Engineered Wood Design .....	174
12.2.2 Conventional Light-Frame Construction .....	174
12.3 ENGINEERED WOOD CONSTRUCTION .....	175
12.3.1 General .....	175
12.3.2 Framing Requirements .....	175
12.3.3 Deformation Compatibility Requirements .....	175
12.3.4 Design Limitations .....	175
12.4 DIAPHRAGMS AND SHEAR WALLS .....	178
12.4.1 Diaphragm and Shear Wall Aspect Ratios .....	178
12.4.2 Shear Resistance Based on Principles of Mechanics .....	178
12.4.3 Sheathing Requirements .....	178
12.5 CONVENTIONAL LIGHT-FRAME CONSTRUCTION .....	180
12.5.1 Scope .....	180
12.5.2 Braced Walls .....	185
12.5.3 Detailing Requirements .....	185
12.6 SEISMIC DESIGN CATEGORY A .....	188
12.7 SEISMIC DESIGN CATEGORIES B, C, AND D .....	188
12.7.1 Conventional Light-Frame Construction .....	189
12.7.2 Engineered Construction .....	189
12.8 SEISMIC DESIGN CATEGORIES E AND F .....	189
12.8.1 Limitations .....	189

<b>Chapter 13, SEISMICALLY ISOLATED STRUCTURES DESIGN REQUIREMENTS</b> .....	<b>201</b>
13.1 GENERAL .....	201
13.2 CRITERIA SELECTION .....	201
13.2.1 Basis for Design .....	201
13.2.2 Stability of the Isolation System .....	201
13.2.3 Seismic Use Group .....	201
13.2.4 Configuration Requirements .....	201
13.2.5 Selection of Lateral Response Procedure .....	201
13.3 EQUIVALENT LATERAL FORCE PROCEDURE .....	203
13.3.1 General .....	203
13.3.2 Deformation Characteristics of the Isolation System .....	203
13.3.3 Minimum Lateral Displacements .....	302
13.3.4 Minimum Lateral Forces .....	206
13.3.5 Vertical Distribution of Force .....	207
13.3.6 Drift Limits .....	208
13.4 DYNAMIC LATERAL RESPONSE PROCEDURE .....	208
13.4.1 General .....	208
13.4.2 Isolation System and Structural Elements Below the Isolation System .....	208
13.4.3 Structural Elements Above the Isolation System .....	209
13.4.4 Ground Motion .....	209
13.4.5 Mathematical Model .....	210
13.4.6 Description of Analysis Procedures .....	211
13.4.7 Design Lateral Force .....	211
13.5 LATERAL LOAD ON ELEMENTS OF <i>STRUCTURES</i> AND NONSTRUCTURAL COMPONENTS SUPPORTED BY BUILDINGS .....	212
13.5.1 General .....	212
13.5.2 Forces and Displacements .....	212
13.6 DETAILED SYSTEM REQUIREMENTS .....	213
13.6.1 General .....	213
13.6.2 Isolation System .....	213
13.6.3 Structural System .....	214
13.7 FOUNDATIONS .....	215
13.8 DESIGN AND CONSTRUCTION REVIEW .....	215
13.8.1 General .....	215
13.8.2 Isolation System .....	215
13.9 REQUIRED TESTS OF THE ISOLATION SYSTEM .....	215
13.9.1 General .....	215
13.9.2 Prototype Tests .....	216
13.9.3 Determination of Force-Deflection Characteristics .....	217
13.9.4 Test Specimen Adequacy .....	218
13.9.5 Design Properties of the Isolation System .....	218
Appendix to Chapter 13, PASSIVE ENERGY DISSIPATION .....	221



<b>Chapter 14, NONBUILDING STRUCTURE DESIGN REQUIREMENTS</b> .....	<b>223</b>
14.1 GENERAL .....	223
14.1.1 Scope .....	223
14.1.2 Nonbuilding Structures Supported by Other Structures .....	223
14.1.3 Architectural, Mechanical, and Electrical Components .....	224
14.1.4 Loads .....	224
14.1.5 Fundamental Period .....	224
14.1.6 Drift Limitations .....	224
14.1.7 Materials Requirements .....	224
14.2 STRUCTURAL DESIGN REQUIREMENTS .....	224
14.2.1 Design Basis .....	224
14.2.2 Rigid Nonbuilding Structures .....	228
14.2.3 Deflection Limits and Structure Separation .....	228
14.3 NONBUILDING STRUCTURES SIMILAR TO BUILDINGS .....	228
14.3.1 General .....	228
14.3.2 Pipe Racks .....	229
14.3.3 Steel Storage Racks .....	229
14.3.4 Electrical Power Generating Facilities .....	230
14.3.5 Structural Towers for Tanks and Vessels .....	230
14.3.6 Piers and Wharves .....	231
14.4 NONBUILDING STRUCTURES NOT SIMILAR TO BUILDINGS .....	231
14.4.1 General .....	231
14.4.2 Earth Retaining Structures .....	231
14.4.3 Tanks and Vessels .....	231
14.4.4 Electrical Transmission, Substation, and Distribution Structures .....	232
14.4.5 Telecommunication Towers .....	232
14.4.6 Stacks and Chimneys .....	232
14.4.7 Amusement Structures .....	232
14.4.8 Special Hydraulic Structures .....	233
14.4.9 Buried Structures .....	233
14.4.10 Inverted Pendulums .....	233
Appendix to Chapter 14 .....	235
<b>Appendix A, DIFFERENCES BETWEEN THE 1994 AND 1997 EDITIONS OF THE NEHRP RECOMMENDED PROVISIONS</b> .....	<b>255</b>
<b>Appendix B, BSSC 1997 UPDATE PROGRAM PARTICIPANTS</b> .....	<b>301</b>

**NOTE:** Earlier editions of the *Provisions* featured marginal lines to highlight where changes had been made. Because the structure of the *Provisions* has been thoroughly revised for 1997 and a number of broad editorial changes have been made, the marginal lines are not used. Rather, readers are urged to review Appendix A of this *Provisions* volume for a description of the changes made and a comparison of the tables of contents of the 1994 and 1997 Editions.

# Chapter 1

## GENERAL PROVISIONS

**1.1 PURPOSE:** The *NEHRP Recommended Provisions for Seismic Regulations for New Buildings and Other Structures* (referred to hereinafter as the *Provisions*) present criteria for the design and construction of *structures* to resist earthquake ground motions. The purposes of these *Provisions* are as follows:

1. To provide minimum design criteria for *structures* appropriate to their primary function and use considering the need to protect the health, safety, and welfare of the general public by minimizing the earthquake-related risk to life and
2. To improve the capability of *essential facilities* and *structures* containing substantial quantities of hazardous materials to function during and after *design earthquakes*.

The *design earthquake ground motion* levels specified herein could result in both structural and nonstructural damage. For most *structures* designed and constructed according to these *Provisions*, structural damage from the *design earthquake ground motion* would be repairable although perhaps not economically so. For *essential facilities*, it is expected that the damage from the *design earthquake ground motion* would not be so severe as to preclude continued occupancy and function of the facility. The actual ability to accomplish these goals depends upon a number of factors including the structural framing type, configuration, materials, and as-built details of construction. For ground motions larger than the design levels, the intent of these *Provisions* is that there be a low likelihood of structural collapse.

### **1.2 SCOPE AND APPLICATION:**

**1.2.1 Scope:** These *Provisions* shall apply to the design and construction of *structures* including *additions*, change of use, and *alterations* to resist the effects of earthquake motions. Every *structure*, and portion thereof, shall be designed and constructed to resist the effects of earthquake motions as prescribed by these *Provisions*.

#### **Exceptions:**

1. Detached one- and two-family dwellings located where  $S_{DS}$  is less than 0.4g are exempt from all requirements of these *Provisions*.
2. Detached one- and two-family wood frame dwellings located where  $S_{DS}$  is equal to or greater than 0.4g and that are designed and constructed in accordance with the conventional light frame construction provisions in Sec. 12.5 are exempt from all other requirements of these *Provisions*.
3. Agricultural storage *structures* intended only for incidental human occupancy are exempt from all requirements of these *Provisions*.

4. Structures located where  $S_I$  is less than or equal to 0.04g and  $S_{DS}$  is less than or equal to 0.15g shall only be required to comply with Sec. 5.2.6.1.

Structures shall be designed and constructed in accordance with these Provisions.

**1.2.2 Additions:** Additions shall be designed and constructed in accordance with the following:

**1.2.2.1:** An addition that is structurally independent from an existing structure shall be designed and constructed as required for a new structure in accordance with Sec. 1.2.1.

**1.2.2.2:** An addition that is not structurally independent from an existing structure shall be designed and constructed such that the entire structure conforms to the seismic-force-resistance requirements for new structures unless all of the following conditions are satisfied:

1. The addition conforms with the requirements for new structures, and
2. The addition does not increase the seismic forces in any structural element of the existing structure by more than 5 percent, unless the capacity of the element subject to the increased forces is still in compliance with these Provisions, and
3. The addition does not decrease the seismic resistance of any structural element of the existing structure to less than that required for a new structure.

**1.2.3 Change of Use:** When a change of use results in a structure being reclassified to a higher Seismic Use Group, the structure shall conform to the requirements of Section 1.2.1 for a new structure.

**Exception:** When a change of use results in a structure being reclassified from Seismic Use Group I to Seismic Use Group II, compliance with these Provisions is not required if the structure is located where  $S_{DS}$  is less than 0.3.

**1.2.4 Alterations:** Alterations are permitted to be made to any structure without requiring the structure to comply with these Provisions provided the alterations conform to that required for a new structure. Alterations shall not decrease the lateral-force resisting system strength or stiffness to less than that required by these Provisions. The alteration shall not cause the existing structural elements to be loaded beyond their capacity.

**1.2.5 Alternate Materials and Alternate Means and Methods of Construction:** Alternate materials and alternate means and methods of construction to those prescribed in these Provisions are permitted if approved by the authority having jurisdiction. Substantiating evidence shall be submitted demonstrating that the proposed alternate, for the purpose intended, will be at least equal in strength, durability, and seismic resistance.

**1.3 SEISMIC USE GROUPS:** All structures shall be assigned to one of the following Seismic Use Groups:

**1.3.1 Seismic Use Group III:** Seismic Use Group III structures are those having essential facilities that are required for post-earthquake recovery and those containing substantial quantities of hazardous substances including:

1. Fire, rescue, and police stations

2. Hospitals
3. Designated medical facilities having emergency treatment facilities
4. Designated emergency preparedness centers
5. Designated emergency operation centers
6. Designated emergency shelters
7. Power generating stations or other utilities required as emergency back-up facilities for *Seismic Use Group III* facilities
8. Emergency vehicle garages and emergency aircraft hangars
9. Designated communication centers
10. Aviation control towers and air traffic control centers
11. *Structures* containing sufficient quantities of toxic or explosive substances deemed to be hazardous to the public
12. Water treatment facilities required to maintain water pressure for fire suppression.

**1.3.2 Seismic Use Group II:** *Seismic Use Group II structures* are those that have a substantial public hazard due to occupancy or use including:

1. Covered *structures* whose primary occupancy is public assembly with a capacity greater than 300 persons
2. Educational *structures* through the 12th grade with a capacity greater than
3. Day care centers with a capacity greater than 150
4. Medical facilities with greater than 50 resident incapacitated patients not otherwise designated a *Seismic Use Group III structure*
5. Jails and detention facilities
6. All *structures* with a capacity greater than 5,000 persons
7. Power generating stations and other public utility facilities not included in *Seismic Use Group III* and required for continued operation
8. Water treatment facilities required for primary treatment and disinfection for potable water
9. Waste water treatment facilities required for primary treatment

**1.3.3 Seismic Use Group I:** *Seismic Use Group I structures* are those not assigned to *Seismic Use Groups III* or *II*.

**1.3.4 Multiple Use:** *Structures* having multiple uses shall be assigned the classification of the use having the highest *Seismic Use Group* except in *structures* having two or more portions which are structurally separated in accordance with Sec. 5.2.8, each portion shall be separately classified. Where a structurally separated portion of a *structure* provides access to, egress from,

or shares life safety *components* with another portion having a higher *Seismic Use Group*, the lower portion shall be assigned the same rating as the higher.

**1.3.5 Seismic Use Group III Structure Access Protection:** Where operational access to a *Seismic Use Group III structure* is required through an adjacent *structure*, the adjacent *structure* shall conform to the requirements for *Seismic Use Group III structures*. Where operational access is less than 10 ft (3 m) from an interior lot line or less than 10 ft (3 m) from another *structure*, access protection from potential falling debris shall be provided by the *owner* of the *Seismic Use Group III structure*.

**1.4 OCCUPANCY IMPORTANCE FACTOR:** An *occupancy importance factor, I*, shall be assigned to each *structure* in accordance with Table 1.4.

**TABLE 1.4 Occupancy Importance Factors**

<b>Seismic Use Group</b>	<b><i>I</i></b>
I	1.0
II	1.25
III	1.5

## Chapter 2

# GLOSSARY AND NOTATIONS

### 2.1 GLOSSARY:

**Active Fault:** A fault for which there is an average historic slip rate of 1 mm per year or more and geologic evidence of seismic activity within Holocene times (past 11,000 years).

**Addition:** An increase in *building* area, aggregate floor area, height, or number of stories of a *structure*.

**Adjusted Resistance ( $D'$ ):** The reference resistance adjusted to include the effects of all applicable adjustment factors resulting from end use and other modifying factors. Time effect factor ( $\lambda$ ) adjustments are not included.

**Alteration:** Any construction or renovation to an existing *structure* other than an *addition*.

**Appendage:** An architectural *component* such as a canopy, marquee, ornamental balcony, or statuary.

**Approval:** The written acceptance by the authority having jurisdiction of documentation that establishes the qualification of a material, system, *component*, procedure, or person to fulfill the requirements of these provisions for the intended use.

**Architectural Component Support:** Those structural members or assemblies of members, including braces, frames, struts and attachments, that transmit all loads and forces between architectural systems, *components*, or *elements* and the *structure*.

**Attachments:** Means by which *components* and their supports are secured or connected to the *seismic-force-resisting system* of the *structure*. Such *attachments* include anchor bolts, welded connections, and mechanical fasteners.

**Base:** The level at which the horizontal seismic ground motions are considered to be imparted to the *structure*.

**Base Shear:** Total design lateral force or shear at the *base*.

**Basement.** A *basement* is any story below the lowest *story above grade*.

**Boundary Elements:** *Diaphragm* and *shear wall boundary members* to which sheathing transfers forces. *Boundary members* include chords and *drag struts* at *diaphragm* and *shear wall* perimeters, interior openings, discontinuities, and re-entrant corners.

**Braced Wall Line:** A series of *braced wall panels* in a single *story* that meets the requirements of Sec. 12.5.2.

**Braced Wall Panel:** A section of *wall* braced in accordance with Sec. 12.5.2.

**Building:** Any *structure* whose use could include shelter of human occupants.

**Boundary Members:** Portions along *wall* and *diaphragm* edges strengthened by longitudinal and transverse reinforcement and/or structural steel members.

**Cantilevered Column System:** A *seismic-force-resisting system* in which lateral forces are resisted entirely by columns acting as cantilevers from the foundation.

**Component:** A part or *element* of an architectural, electrical, mechanical, or structural system.

**Component, Equipment:** A mechanical or electrical *component* or *element* that is part of a mechanical and/or electrical system within or without a *building* system.

**Component, Flexible:** *Component*, including its *attachments*, having a fundamental period greater than 0.06 sec.

**Component, Rigid:** *Component*, including its *attachments*, having a fundamental period less than or equal to 0.06 sec.

**Concrete:**

**Plain Concrete:** *Concrete* that is either unreinforced or contains less reinforcement than the minimum amount specified in Ref. 6-1 for *reinforced concrete*.

**Reinforced Concrete:** *Concrete* reinforced with no less than the minimum amount required by Ref. 6-1, prestressed or nonprestressed, and designed on the assumption that the two materials act together in resisting forces.

**Confined Region:** That portion of a *reinforced concrete component* in which the concrete is confined by closely spaced *special transverse reinforcement* restraining the concrete in directions perpendicular to the applied stress.

**Construction Documents:** The written, graphic, electronic, and pictorial documents describing the design, locations, and physical characteristics of the project required to verify compliance with these *Provisions*.

**Container:** A large-scale independent *component* used as a receptacle or vessel to accommodate plants, refuse, or similar uses.

**Coupling Beam:** A beam that is used to connect adjacent concrete *wall* piers to make them act together as a unit to resist lateral loads.

**Deformability:** The ratio of the ultimate *deformation* to the limit *deformation*.

**High Deformability Element:** An *element* whose *deformability* is not less than 3.5 when subjected to four fully reversed cycles at the limit *deformation*.

**Limited Deformability Element:** An *element* that is neither a low *deformability* or a high *deformability element*.

**Low Deformability Element:** An *element* whose *deformability* is 1.5 or less.



**Deformation:**

**Limit Deformation:** Two times the initial *deformation* that occurs at a load equal to 40 percent of the maximum strength.

**Ultimate Deformation:** The *deformation* at which failure occurs and which shall be deemed to occur if the sustainable load reduces to 80 percent or less of the maximum strength.

**Design Earthquake Ground Motion:** The earthquake effects that *buildings* and *structures* are specifically proportioned to resist as defined in Sec. 4.1.

**Design Earthquake:** Earthquake effects that are two-thirds of the corresponding *maximum considered earthquake*.

**Designated Seismic System:** Those architectural, electrical, and mechanical systems and their *components* that require design in accordance with Sec. 6.1 and that have a *component* importance factor ( $I_p$ ) greater than 1.

**Diaphragm:** A horizontal or nearly horizontal system acting to transfer lateral forces to the vertical resisting *elements*. *Diaphragms* are classified as either flexible or rigid according to the requirements of Sec. 5.2.3.1 and 12.3.4.2.

**Diaphragm, Blocked:** A *diaphragm* in which all sheathing edges not occurring on a framing member are supported on and fastened to blocking.

**Diaphragm Boundary:** A location where shear is transferred into or out of the *diaphragm* sheathing. Transfer is either to a *boundary element* or to another force-resisting *element*.

**Diaphragm Chord:** A *diaphragm boundary element* perpendicular to the applied load that is assumed to take axial stresses due to the *diaphragm* moment in a manner analogous to the flanges of a beam. Also applies to *shear walls*.

**Displacement**

**Design Displacement:** The *design earthquake* lateral *displacement*, excluding additional *displacement* due to actual and accidental torsion, required for design of the *isolation system*.

**Total Design Displacement:** The *design earthquake* lateral *displacement*, including additional *displacement* due to actual and accidental torsion, required for design of the *isolation system* or an *element* thereof.

**Total Maximum Displacement:** The *maximum considered earthquake* lateral *displacement*, including additional *displacement* due to actual and accidental torsion, required for verification of the stability of the *isolation system* or *elements* thereof, design of *structure* separations, and vertical load testing of *isolator unit* prototypes.

**Displacement Restraint System:** A collection of structural *elements* that limits lateral *displacement* of seismically isolated structures due to *maximum considered earthquake* ground shaking.

**Drag Strut (Collector, Tie, Diaphragm Strut):** A *diaphragm* or *shear wall boundary element* parallel to the applied load that collects and transfers *diaphragm* shear forces to the vertical-force-resisting *elements* or distributes forces within the *diaphragm* or *shear wall*. A *drag strut*

often is an extension of a *boundary element* that transfers forces into the *diaphragm* or *shear wall*.

**Effective Damping:** The value of equivalent viscous damping corresponding to energy dissipated during cyclic response of the *isolation system*.

**Effective Stiffness:** The value of the lateral force in the *isolation system*, or an *element* thereof, divided by the corresponding lateral *displacement*.

**Enclosure:** An interior space surrounded by *walls*.

**Equipment Support:** Those structural members or assemblies of members or manufactured *elements*, including braces, frames, legs, lugs, snuggers, hangers or saddles, that transmit *gravity load* and operating load between the equipment and the *structure*.

**Essential Facility:** A facility or *structure* required for post-earthquake recovery.

**Factored Resistance ( $\lambda\phi D$ ):** *Reference resistance* multiplied by the time effect and resistance factors. This value must be adjusted for other factors such as size effects, moisture conditions, and other end-use factors.

**Flexible Equipment Connections:** Those connections between equipment *components* that permit rotational and/or translational movement without degradation of performance. Examples include universal joints, bellows expansion joints, and flexible metal hose.

**Frame:**

**Braced Frame:** An essentially vertical truss, or its equivalent, of the concentric or eccentric type that is provided in a *building frame system* or *dual frame system* to resist shear.

**Centrically Braced Frame (CBF):** A *braced frame* in which the members are subjected primarily to axial forces.

**Eccentrically Braced Frame (EBF):** A diagonally *braced frame* in which at least one end of each brace frames into a beam a short distance from a beam-column joint or from another diagonal brace.

**Ordinary Centrically Braced Frame (OCBF):** A steel *centrically braced frame* in which members and connections are designed in accordance with the provisions of Ref. 8-3 without modification.

**Special Centrically Braced Frame (SCBF):** A steel or composite steel and concrete *centrically braced frame* in which members and connections are designed for ductile behavior.

**Moment Frame:** A frame provided with restrained connections between the beams and columns to permit the frame to resist lateral forces through the flexural rigidity and strength of its members.

**Intermediate Moment Frame:** A *moment frame* of reinforced concrete meeting the detailing requirements of Ref. 9-1, Sec. 21.8, of structural steel meeting the detailing requirements of Ref. 8-3, Sec. 10, or of composite construction meeting the requirements of Ref. 10-3, Part II, Sec. 6.4b, 7, 8 and 10.

**Ordinary Moment Frame:** A *moment frame* of reinforced concrete conforming to the requirements of Ref. 9-1 exclusive of Chapter 21, of structural steel meeting the detailing requirements of Ref. 8-3, Sec. 12, or of composite construction meeting the requirements of Ref. 10-3, Part II, Sec. 6.4a, 7, 8 and 11.

**Special Moment Frame (SMF):** A *moment frame* of reinforced concrete meeting the detailing requirements of Ref. 9-1, Sec. 21.2 through 21.5, of structural steel meeting the detailing requirements of Ref. 8-3, Sec. 9, or of composite construction meeting the requirements of Ref. 10-3, Part II, Sec. 6.4a, 7, 8 and 9.

### Frame System:

**Building Frame System:** A structural system with an essentially complete *space frame system* providing support for vertical loads. Seismic-force resistance is provided by *shear walls* or *braced frames*.

**Dual Frame System:** A structural system with an essentially complete *space frame system* providing support for vertical loads. Seismic force resistance is provided by a *moment resisting frame* and *shear walls* or *braced frames* as prescribed in Sec. 5.2.2.1.

**Space Frame System:** A structural system composed of interconnected members, other than *bearing walls*, that is capable of supporting vertical loads and that also may provide resistance to shear.

**Grade Plane.** A reference plane representing the average of finished ground level adjoining the *structure* at all exterior *walls*. Where the finished ground level slopes away from the exterior walls, the reference plane shall be established by the lowest points within the area between the *buildings* and the lot line or, where the lot line is more than 6 ft. (1829 mm) from the *structure*, between the *structure* and a point 6 ft. (1829 mm) from the *structure*.

**Hazardous Contents:** A material that is highly toxic or potentially explosive and in sufficient quantity to pose a significant life-safety threat to the general public if an uncontrolled release were to occur.

**High Temperature Energy Source:** A fluid, gas, or vapor whose temperature exceeds 220 degrees F (378 K).

**Inspection, Special:** The observation of the work by the *special inspector* to determine compliance with the approved *construction documents* and these *Provisions*.

**Continuous Special Inspection:** The full-time observation of the work by an approved *special inspector* who is present in the area where work is being performed.

**Periodic Special Inspection:** The part-time or intermittent observation of the work by an approved *special inspector* who is present in the area where work has been or is being performed.

**Inspector, Special (who shall be identified as the Owner's Inspector):** A person approved by the authority having jurisdiction as being qualified to perform *special inspection* required by the approved *quality assurance plan*. The quality assurance personnel of a fabricator is permitted to be approved by the authority having jurisdiction as a *special inspector*.

**Inverted Pendulum Type Structures:** *Structures* that have a large portion of their mass concentrated near the top and, thus, have essentially one degree of freedom in horizontal translation. The *structures* are usually T-shaped with a single column supporting the beams or framing at the top.

**Isolation Interface:** The boundary between the upper portion of the *structure*, which is isolated, and the lower portion of the *structure*, which moves rigidly with the ground.

**Isolation System:** The collection of structural *elements* that includes all individual *isolator units*, all structural *elements* that transfer force between *elements* of the *isolation system*, and all connections to other structural *elements*. The *isolation system* also includes the *wind-restraint system*, energy-dissipation devices, and/or the *displacement restraint system* if such systems and devices are used to meet the design requirements of Chapter 13.

**Isolator Unit:** A horizontally flexible and vertically stiff structural *element* of the *isolation system* that permits large lateral *deformations* under design seismic load. An *isolator unit* is permitted to be used either as part of or in addition to the weight-supporting system of the *structure*.

**Joint:** That portion of a *column* bounded by the highest and lowest surfaces of the other members framing into it.

**Load:**

**Dead Load:** The *gravity load* due to the weight of all permanent structural and nonstructural *components* of a *building* such as *walls*, floors, roofs, and the operating weight of fixed service equipment.

**Gravity Load (W):** The total *dead load* and applicable portions of other loads as defined in Sec. 5.3.2.

**Live Load:** The load superimposed by the use and occupancy of the *building* not including the wind load, earthquake load, or *dead load*; see Sec. 5.3.2.

**Maximum Considered Earthquake Ground Motion:** The most severe earthquake effects considered by these *Provisions* as defined in Sec. 4.1.

**Nonbuilding Structure:** A *structure*, other than a *building*, constructed of a type included in Chapter 14 and within the limits of Sec. 14.1.1.

**Occupancy Importance Factor:** A factor assigned to each *structure* according to its *Seismic Use Group* as prescribed in Sec. 1.4.

**Owner:** Any person, agent, firm, or corporation having a legal or equitable interest in the property.

**Partition:** A nonstructural interior *wall* that spans from floor to ceiling, to the floor or roof structure immediately above, or to subsidiary structural members attached to the *structure* above.

**P-Delta Effect:** The secondary effect on shears and moments of structural members induced due to *displacement* of the *structure*.

**Quality Assurance Plan:** A detailed written procedure that establishes the systems and *components* subject to *special inspection* and testing.

**Reference Resistance ( $D$ ):** The resistance (force or moment as appropriate) of a member or connection computed at the reference end use conditions.

**Registered Design Professional:** An architect or engineer, registered or licensed to practice professional architecture or engineering, as defined by the statutory requirements of the professional registrations laws of the state in which the project is to be constructed.

**Roofing Unit:** A unit of roofing material weighing more than 1 pound (0.5 kg).

**Seismic Design Category:** A classification assigned to a *structure* based on its *Seismic Use Group* and the severity of the *design earthquake* ground motion at the site.

**Seismic-Force-Resisting System:** That part of the structural system that has been considered in the design to provide the required resistance to the *shear wall* prescribed herein.

**Seismic Forces:** The assumed forces prescribed herein, related to the response of the *structure* to earthquake motions, to be used in the design of the *structure* and its *components*.

**Seismic Response Coefficient:** Coefficient  $C_s$  as determined from Sec. 5.3.2.1.

**Seismic Use Group:** A classification assigned to a *structure* based on its use as defined in Sec. 1.3.

**Shallow Anchors:** Anchors with embedment length-to-diameter ratios of less than 8.

**Shear Panel:** A floor, roof, or *wall component* sheathed to act as a *shear wall* or *diaphragm*.

**Site Class:** A classification assigned to a site based on the types of soils present and their engineering properties as defined in Sec. 4.1.2.

**Site Coefficients:** The values of  $F_a$  and  $F_v$  indicated in Tables 1.4.2.3a and 1.4.2.3b, respectively.

**Special Transverse Reinforcement:** Reinforcement composed of spirals, closed stirrups, or hoops and supplementary cross-ties provided to restrain the concrete and qualify the portion of the *component*, where used, as a confined region.

**Storage Racks:** Include industrial pallet racks, movable shelf racks, and stacker racks made of cold-formed or hot-rolled structural members. Does not include other types of racks such as drive-in and drive-through racks, cantilever racks, portable racks, or racks made of materials other than steel.

**Story:** The portion of a *structure* between the top to top of two successive finished floor surfaces and, for the topmost story, from the top of the floor finish to the top of the roof structural *element*.

**Story Above Grade:** Any *story* having its finished floor surface entirely above grade, except that a *story* shall be considered as a *story above grade* where the finished floor surface of the *story* immediately above is more that 6

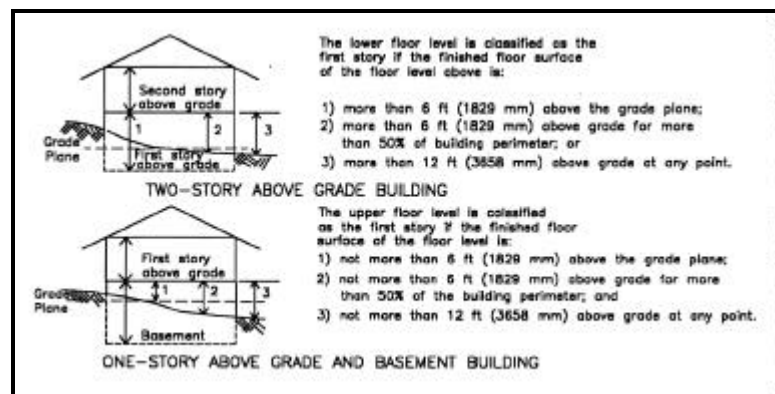

FIGURE 2.1 Definition of story above grade.

ft (1829 mm ) above the *grade plane*, more than 6 ft (1829 mm) above the finished ground level for more than 40 percent of the total *structure* perimeter, or more than 12 ft (3658mm ) above the finished ground level at any point. This definition is illustrated in Figure 2.1.

**Story Drift Ratio:** The *story drift*, as determined in Sec. 5.3.7, divided by the *story height*.

**Story Shear:** The summation of design lateral forces at levels above the *story* under consideration.

**Strength:**

**Design Strength:** *Nominal strength* multiplied by a strength reduction factor,  $\phi$ .

**Nominal Strength:** Strength of a member or cross section calculated in accordance with the requirements and assumptions of the strength design methods of these *Provisions* (or the referenced standards) before application of any strength reduction factors.

**Required Strength:** Strength of a member, cross section, or connection required to resist factored loads or related internal moments and forces in such combinations as stipulated by these *Provisions*.

**Structure:** That which is built or constructed and limited to *buildings* and *nonbuilding structures* as defined herein.

**Structural Observations:** The visual observations performed by the *registered design professional* in responsible charge (or another *registered design professional*) to determine that the *seismic-force-resisting system* is constructed in general conformance with the *construction documents*.

**Structural-Use Panel:** A wood-based panel product that meets the requirements of Ref. 12-10 or 12-11 and is bonded with a waterproof adhesive. Included under this designation are plywood, oriented strand board, and composite panels.

**Subdiaphragm:** A portion of a diaphragm used to transfer *wall* anchorage forces to *diaphragm* cross ties.

**Testing Agency:** A company or corporation that provides testing and/or inspection services. The person in responsible charge of the *special inspector(s)* and the testing services shall be a *registered design professional*.

**Tie-Down (Hold-Down):** A device used to resist uplift of the chords of *shear walls*. These devices are intended to resist load without significant slip between the device and the *shear wall* chord or be shown with cyclic testing to not reduce the *wall* capacity or ductility.

**Time Effect Factor ( $\lambda$ ):** A factor applied to the adjusted resistance to account for effects of duration of load.

**Torsional Force Distribution:** The distribution of horizontal *shear wall* through a rigid *diaphragm* when the center of mass of the *structure* at the level under consideration does not coincide with the center of rigidity (sometimes referred to as *diaphragm* rotation).

**Toughness:** The ability of a material to absorb energy without losing significant *strength*.

**Utility or Service Interface:** The connection of the *structure's* mechanical and electrical distribution systems to the utility or service company's distribution system.

**Veneers:** Facings or ornamentation of brick, concrete, stone, tile, or similar materials attached to a backing.

**Wall:** A *component* that has a slope of 60 degrees or greater with the horizontal plane used to enclose or divide space.

**Bearing Wall:** An exterior or interior *wall* providing support for vertical loads.

**Cripple Wall:** A framed stud *wall*, less than 8 feet (2400 mm) in height, extending from the top of the foundation to the underside of the lowest floor framing. *Cripple walls* can occur in both engineered *structures* and conventional construction.

**Light-Framed Wall:** A *wall* with wood or steel studs.

**Light-Framed Wood Shear Wall:** A *wall* constructed with wood studs and sheathed with material rated for shear resistance.

**Nonbearing Wall:** An exterior or interior *wall* that does not provide support for vertical loads other than its own weight or as permitted by the building code administered by the authority having jurisdiction.

**Nonstructural Wall:** All walls other than *bearing walls* or *shear walls*.

**Shear Wall (Vertical Diaphragm):** A *wall* designed to resist lateral forces parallel to the plane of the *wall* (sometimes referred to as a vertical *diaphragm*).

**Wall System, Bearing:** A structural system with *bearing walls* providing support for all or major portions of the vertical loads. *Shear walls* or *braced frames* provide seismic-force resistance.

**Wind-Restraint System:** The collection of structural *elements* that provides restraint of the seismic-isolated *structure* for wind loads. The *wind-restraint system* may be either an integral part of *isolator units* or a separate device.

## 2.2 NOTATIONS:

A, B, C, D, E, F	<i>Site classes</i> as defined in Sec. 4.1.2.
$A_b$	Area (in. <sup>2</sup> or mm <sup>2</sup> ) of anchor bolt or stud in Chapters 6 and 11.
$A_{ch}$	Cross-sectional area (in. <sup>2</sup> or mm <sup>2</sup> ) of a <i>component</i> measured to the outside of the special lateral reinforcement.
$A_n$	Net cross-sectional area of masonry (in. <sup>2</sup> or mm <sup>2</sup> ) in Chapter 11.
$A_o$	The area of the load-carrying foundation (ft <sup>2</sup> or m <sup>2</sup> ).
$A_p$	The area of an assumed failure surface taken as a pyramid in Eq. 9.2.4.1-3 or in Chapter 9.
$A_p$	Projected area on the masonry surface of a right circular cone for anchor bolt allowable shear and tension calculations (in. <sup>2</sup> or mm <sup>2</sup> ) in Chapter 11.
$A_s$	The area of an assumed failure surface taken as a pyramid in Eq. .2.4.1-3 or in Chapter 9.

$A_s$	Cross-sectional area of reinforcement (in. <sup>2</sup> or mm <sup>2</sup> ) in Chapters 6 and 11.
$A_{sh}$	Total cross-sectional area of hoop reinforcement (in. <sup>2</sup> or mm <sup>2</sup> ), including supplementary cross-ties, having a spacing of $s_h$ and crossing a section with a core dimension of $h_c$ .
$A_t$	The area (in. <sup>2</sup> or mm <sup>2</sup> ) of the flat bottom of the truncated pyramid of an assumed concrete failure surface in Sec. 9.2.4.1 or Eq. 9.2.4.1-3.
$A_{vd}$	Required area of leg (in. <sup>2</sup> or mm <sup>2</sup> ) of diagonal reinforcement.
$A_x$	The torsional amplification factor.
$a_b$	Length of compressive stress block (in. or mm) in Chapter 11.
$a_d$	The incremental factor related to <i>P-delta effects</i> in Sec. 5.3.6.2.
$a_p$	The <i>component</i> amplification factor as defined in Sec. 6.1.3.
$B_a$	Nominal axial strength of an anchor bolt (lb or N) in Chapter 11.
$B_D$	Numerical coefficient as set forth in Table 13.3.3.1 for effective damping equal to $D$ .
$B_M$	Numerical coefficient as set forth in Table 13.3.3.1 for effective damping equal to $M$ .
$B_v$	Nominal shear strength of an anchor bolt (lb or N) in Chapter 11.
$b$	The shortest plan dimension of the <i>structure</i> , in feet (mm), measured perpendicular to $d$ .
$b_a$	Factored axial force on an anchor bolt (lb or N) in Chapter 11.
$b$	The shortest plan dimension of the <i>structure</i> , in feet (mm), measured perpendicular to $d_p$ (Sec. 5.6).
$b_v$	Factored shear force on an anchor bolt (lb or N) in Chapter 11.
$b_w$	Web width (in. or mm) in Chapter 11.
$C_u$	Coefficient for upper limit on calculated period; see Table 5.3.3.
$C_d$	The deflection amplification factor as given in Table 5.2.2.
$C_s$	The <i>seismic response coefficient</i> (dimensionless) determined in Sec. 5.3.
$C_s$	The <i>seismic response coefficient</i> (dimensionless) determined in Sec. 5.5.2.1 and 5.5.3.1.
$C_{sm}$	The modal <i>seismic response coefficient</i> (dimensionless) determined in Sec. 5.4.5.
$C_T$	The <i>building</i> period coefficient in Sec. 5.3.3.1.
$C_{vx}$	The vertical distribution factor as determined in Sec. 5.3.4.
$c$	Distance from the neutral axis of a flexural member to the fiber of maximum compressive strain (in. or mm).



---

$c_{eq}$	Effective energy dissipation device damping coefficient (Eq. 13.3.2.1).
$D$	Reference resistance in Chapter 12.
$D$	The effect of <i>dead load</i> in Sec. 5.2.7 and Chapter 13.
$D'$	Adjusted resistance in Chapter 12.
$D_D$	Design displacement, in inches (mm), at the center of rigidity of the <i>isolation system</i> in the direction under consideration as prescribed by Eq. 13.3.3.1.
$D_D'$	Design displacement, in inches (mm), at the center of rigidity of the <i>isolation system</i> in the direction under consideration, as prescribed by Eq. 13.4.2-1.
$D_M$	Maximum displacement, in inches (mm), at the center of rigidity of the <i>isolation system</i> in the direction under consideration, as prescribed by Eq. 13.3.3.3.
$D_M'$	Maximum displacement, in inches (mm), at the center of rigidity of the <i>isolation system</i> in the direction under consideration, as prescribed by Eq. 13.4.2-2 .
$D_p$	Relative seismic displacement that the <i>component</i> must be designed to accommodate as defined in Sec. 6.1.4.
$D_s$	The total depth of the stratum in Eq. 5.5.2.1.2-4 (ft or m).
$D_{TD}$	Total design displacement, in inches (mm), of an <i>element</i> of the <i>isolation system</i> including both translational displacement at the center of rigidity and the <i>component</i> of torsional displacement in the direction under consideration as prescribed by Eq. 13.3.3.5-1.
$D_{TM}$	Total maximum displacement, in inches (mm), of an <i>element</i> of the <i>isolation system</i> including both translational displacement at the center of rigidity and the <i>component</i> of torsional displacement in the direction under consideration as prescribed by Eq. 13.3.3.5-2.
$d$	Overall depth of member (in. or mm) in Chapters 5 and 11.
$d$	The longest plan dimension of the <i>structure</i> , in ft (mm), in Chapter 13.
$d_b$	Diameter of reinforcement (in. or mm) in Chapter 11.
$d_e$	Distance from the anchor axis to the free edge (in. or mm) in Chapter 9.
$d_p$	The longest plan dimension of the <i>structure</i> , in feet (mm).
$E$	The effect of horizontal and vertical earthquake-induced forces (Sec. 5.2.7 and Chapter 13).
$E_{loop}$	Energy dissipated in kip-inches (kN-mm), in an <i>isolator unit</i> during a full cycle of reversible load over a test displacement range from $\Delta^+$ to $\Delta^-$ , as measured by the area enclosed by the loop of the force-deflection curve.
$E_m$	Chord modulus of elasticity of masonry (psi or MPa) in Chapter 11.
$E_s$	Modulus of elasticity of reinforcement (psi or MPa) in Chapter 11.

---

---

$E_v$	Modulus of rigidity of masonry (psi or MPa) in Chapter 11.
$e$	The actual eccentricity, in feet (mm), measured in plan between the center of mass of the <i>structure</i> above the isolation interface and the center of rigidity of the <i>isolation system</i> , plus accidental eccentricity, in feet (mm), taken as 5 percent of the maximum <i>building</i> dimension perpendicular to the direction of force under consideration.
$F_a$	Acceleration-based site coefficient (at 0.3 sec period).
$F^-$	Maximum negative force in an <i>isolator unit</i> during a single cycle of prototype testing at a <i>displacement</i> amplitude of $\Delta^-$ .
$F^+$	Positive force in kips (kN) in an <i>isolator unit</i> during a single cycle of prototype testing at a <i>displacement</i> amplitude of $\Delta^+$ .
$F_i, F_n, F_x$	The portion of the seismic base shear, $V$ , induced at Level $i, n$ , or $x$ , respectively, as determined in Sec. 5.3.4 (kip or kN).
$F_p$	The seismic design force center of gravity and distributed relative to the <i>component's</i> weight distribution as determined in Sec. 6.1.3.
$F_p$	The induced seismic force on connections and anchorages as determined in Sec. 5.2.5.1.
$F_u$	Specified ultimate tensile strength (psi or MPa) of an anchor (Sec. 9.2.4).
$F_v$	Velocity-based site coefficient (at 1.0 sec period).
$F_x$	Total force distributed over the height of the <i>structure</i> above the isolation interface as prescribed by Eq. 13.3.5.
$F_{xm}$	The portion of the seismic <i>base shear</i> , $V_m$ , induced at Level $x$ as determined in Sec. 5.4.6 (kip or kN).
$f_c'$	Specified compressive strength of concrete used in design.
$f_m'$	Specified compressive strength of masonry (psi or MPa) at the age of 28 days unless a different age is specified, Chapter 11.
$f_r$	Modulus of rupture of masonry (psi or MPa) in Chapter 11.
$f_s'$	Ultimate tensile strength (psi or MPa) of the bolt, stud, or insert leg wires. For A307 bolts or A108 studs, is permitted to be assumed to be 60,000 psi (415 MPa).
$f_y$	Specified yield strength of reinforcement (psi or MPa).
$f_{yh}$	Specified yield stress of the special lateral reinforcement (psi or kPa).
$G$	$v_s^2/g$ = the average shear modulus for the soils beneath the foundation at large strain levels (psf or Pa).
$G_o$	$v_{so}^2/g$ = the average shear modulus for the soils beneath the foundation at small strain levels (psf or Pa).
$g$	Acceleration of gravity in in./sec <sup>2</sup> (mm/s <sup>2</sup> ).

---

---

$H$	Thickness of soil.
$h$	The height of a <i>shear wall</i> measured as the maximum clear height from the foundation to the bottom of the floor or roof framing above or the maximum clear height from the top of the floor or roof framing to the bottom of the floor or roof framing above.
$\bar{h}$	The effective height of the <i>building</i> as determined in Sec. 5.5.2 or 5.5.3 (ft or m).
$h$	Height of a wood shear panel or <i>diaphragm</i> (ft or mm) in Chapter 12.
$h$	The roof elevation of a <i>structure</i> in Chapter 6.
$h$	Height of the member between points of support (in. or mm) in Chapter 11.
$h_c$	The core dimension of a <i>component</i> measured to the outside of the special lateral reinforcement (in. or mm).
$h_i, h_n, h_x$	The height above the <i>base</i> Level $I, n$ , or $x$ , respectively (ft or m).
$h_{sx}$	The <i>story</i> height below Level $x = h_x - h_{x-1}$ (ft or m).
$I$	The <i>occupancy importance factor</i> in Sec. 1.4.
$I_{cr}$	Moment of inertia of the cracked section (in. <sup>4</sup> or mm <sup>4</sup> ) in Chapter 11.
$I_n$	Moment of inertia of the net cross-sectional area of a member (in. <sup>4</sup> or mm <sup>4</sup> ) in Chapter 11.
$I_o$	The static moment of inertia of the load-carrying foundation; see Sec. 5.5.2.1 (in <sup>4</sup> or mm <sup>4</sup> ).
$I_p$	The <i>component</i> importance factor as prescribed in Sec. 6.1.5.
$I$	The <i>building</i> level referred to by the subscript $I$ ; $I = 1$ designates the first level above the <i>base</i> .
$K_p$	The stiffness of <i>component</i> or attachment as defined in Sec. 6.3.3.
$K_y$	The lateral stiffness of the foundation as defined in Sec. 5.5.2.1.1 (lb/in. or N/m).
$K$	The rocking stiffness of the foundation as defined in Sec. 5.5.2.1.1 (ft·lb/degree or N·m/rad).
$KL/r$	The lateral slenderness of a compression member measured in terms of its effective buckling length, $KL$ , and the least radius of gyration of the member cross section, $r$ .
$k$	The distribution exponent given in Sec. 5.3.4
$K_{dmax}$	Maximum effective stiffness, in kips/inch (kN/mm), of the <i>isolation system</i> at the <i>design displacement</i> in the horizontal direction under consideration as prescribed by Eq. 13.9.5.1-1.

---

$K_{Dmin}$	Minimum effective stiffness, in kips/inch (kN/mm), of the <i>isolation system</i> at the <i>design displacement</i> in the horizontal direction under consideration as prescribed by Eq. 13.9.5.1-2.
$K_{max}$	Maximum effective stiffness, in kips/inch (kN/mm), of the <i>isolation system</i> at the maximum <i>displacement</i> in the horizontal direction under consideration as prescribed by Eq. 13.9.5.1-3.
$K_{Min}$	Minimum effective stiffness, in kips/inch (kN/mm), of the <i>isolation system</i> at the maximum <i>displacement</i> in the horizontal direction under consideration, as prescribed by Eq. 13.9.5.1-4.
$k_{eff}$	Effective stiffness of an <i>isolator unit</i> , as prescribed by Eq. 13.9.3-1.
$\bar{k}$	The stiffness of the <i>building</i> as determined in Sec. 5.5.2.1.1 (lb/ft or N/m).
$L$	The overall length of the <i>building</i> (ft or m) at the <i>base</i> in the direction being analyzed.
$L$	Length of bracing member (in. or mm) in Chapter 8.
$L$	Length of coupling beam between coupled <i>shear walls</i> in Chapter 11 (in. or mm).
$L$	The effect of <i>live load</i> in Chapter 13.
$L_o$	The overall length of the side of the foundation in the direction being analyzed, Sec. 5.5.2.1.2 (ft or m).
$l$	The dimension of a <i>diaphragm</i> perpendicular to the direction of application of force. For open-front <i>structures</i> , $l$ is the length from the edge of the <i>diaphragm</i> at the open front to the vertical resisting <i>elements</i> parallel to the direction of the applied force. For a cantilevered <i>diaphragm</i> , $l$ is the length of the cantilever.
$l_b$	Effective embedment length of anchor bolt (in. or mm) in Chapter 11.
$l_{be}$	Anchor bolt edge distance (in. or mm) in Chapter 11.
$l_d$	Development length (in. or mm) in Chapter 11.
$l_{dh}$	Equivalent development length for a standard hook (in. or mm) in Chapter 11.
$l_{ld}$	Minimum lap splice length (in. or mm) in Chapter 11.
$M$	Moment on a masonry section due to unfactored loads (in.·lb or N·mm) in Chapter 11.
$M_a$	Maximum moment in a member at stage deflection is computed (in.·lb or N·mm) in Chapter 11.
$M_{cr}$	Cracking moment strength of the masonry (in.·lb or N·mm) in the Chapter 11.
$M_d$	Design moment strength (in.·lb or N·mm) in Chapter 11.
$M_f$	The foundation overturning design moment as defined in Sec. 5.3.6 (ft·kip or kN·m).

---

$M_o, M_{ol}$	The overturning moment at the foundation-soil interface as determined in Sec. 5.5.2.3 and 5.5.3.2 (ft·lb or N·m).
$M_{nb}$	Unfactored ultimate moment capacity at balanced strain conditions (Sec. 7.5.3.4).
$M_t$	The torsional moment resulting from the location of the <i>building</i> masses, Sec. 5.3.5.1 (ft·kip or kN·m).
$M_{ta}$	The accidental torsional moment as determined in Sec. 5.3.5.1 (ft·kip or kN·m).
$M_u$	Required flexural strength due to factored loads (in·lb or N·mm) in Chapter 11.
$M_1, M_2$	Nominal moment strength at the ends of the coupling beam (in·lb or N·mm) in Chapter 11.
$M_x$	The <i>building</i> overturning design moment at Level $x$ as defined in Sec. 5.3.6 or Sec. 5.4.10 (ft·kip or kN·m).
$m$	A subscript denoting the mode of vibration under consideration; i.e., $m = 1$ for the fundamental mode.
$N$	Number of <i>stories</i> , Sec. 5.3.3.1.
$N$	Standard penetration resistance, ASTM D1536-84.
$N$	Average field standard penetration test for the top 100 ft (30 m); see Sec. 4.1.2.1.
$N_{ch}$	Average standard penetration for cohesionless soil layers for the top 100 ft (30 m); see Sec. 4.1.2.1.
$N_v$	Force acting normal to shear surface (lb or N) in Chapter 11.
$n$	Designates the level that is uppermost in the main portion of the <i>building</i> .
$n$	Number of anchors (Sec. 9.2.4).
$P$	Axial load on a masonry section due to unfactored loads (lb or N) in Chapter 11.
$P_c$	Design tensile strength governed by concrete failure of anchor bolts (Sec. 9.2.4).
$P_D$	Required axial strength on a column resulting from application of <i>dead load</i> , $D$ , in Chapter 5 (kip or kN).
$P_E$	Required axial strength on a column resulting from application of the amplified earthquake load, $E'$ , in Chapter 5 (kip or kN).
$P_L$	Required axial strength on a column resulting from application of <i>live load</i> , $L$ , in Chapter 5 (kip or kN).
$P_n$	Nominal axial load strength (lb or N) in Chapter 8.

---

$P_n$	The algebraic sum of the <i>shear wall</i> and the minimum gravity loads on the joint surface acting simultaneously with the shear (lb or N).
$P_n$	Nominal axial load strength (lb or N) in Chapter 11.
$P_s$	Design tensile strength governed by steel of anchor bolts in Chapter 9.
$P_u$	Required axial load (lb or N) in Chapter 11.
$P_u$	Tensile strength required due to factored loads (lb or N) in Chapter 9.
$P_u^*$	Required axial strength on a brace (kip or kN) in Chapter 8.
$P_x$	The total unfactored vertical design load at and above Level $x$ (kip or kN).
$PI$	Plasticity index, ASTM D4318-93.
$Q_E$	The effect of horizontal <i>building</i> forces (kip or kN); see Sec. 5.2.6.
$Q_V$	The load equivalent to the effect of the horizontal and vertical shear strength of the vertical segment, Appendix to Chapter 8.
$R$	The response modification coefficient as given in Table 5.2.2.
$R_I$	Numerical coefficient related to the type of lateral-force-resisting system above the <i>isolation system</i> as set forth in Table 13.3.4.2 for seismically isolated <i>structures</i> .
$R_p$	The <i>component</i> response modification factor as defined in Sec. 6.1.3.
$r$	A characteristic length of the foundation as defined in Sec. 5.5.2.1 (ft or m).
$r$	Radius of gyration (in. or mm) in Chapter 11.
$r_a$	The characteristic foundation length defined by Eq. 5.5.2.1.2-2 (ft or m).
$r_m$	The characteristic foundation length as defined by Eq. 5.5.2.1.2-3 (ft or m).
$r_x$	The ratio of the design <i>story shear</i> resisted by the most heavily loaded single <i>element</i> in the story, in direction $x$ , to the total <i>story shear</i> .
$S$	Section modulus based on net cross sectional area of a <i>wall</i> (in. <sup>3</sup> or mm <sup>3</sup> ) in Chapter 11.
$S_I$	The mapped <i>maximum considered earthquake</i> , 5% damped, spectral response acceleration at a period of 1 second as defined in Sec. 4.1.1.
$S_{DI}$	The design, 5% damped, spectral response acceleration at a period of one second as defined in Sec. 4.1.2.
$S_{DS}$	The design, 5% damped, spectral response acceleration at short periods as defined in Sec. 4.1.2.
$S_{MI}$	The <i>maximum considered earthquake</i> , 5 percent damped, spectral response acceleration at a period of 1 second adjusted for <i>site class</i> effects as defined in Sec. 4.1.2.

---

$S_{MS}$	The <i>maximum considered earthquake</i> , 5% damped, spectral response acceleration at short periods adjusted for <i>site class</i> effects as defined in Sec. 4.1.2.
$S_S$	The mapped <i>maximum considered earthquake</i> , 5% damped, spectral response acceleration at short periods as defined in Sec. 4.1.2.
$S_{pr}$	Probable strength of precast <i>element</i> connectors (Sec. 9A.5.1).
$\bar{s}_u$	Average undrained shear strength in top 100 ft (30.5 m); see Sec. 4.1.2.1, ASTM D2166-91 or ASTM D2850-87.
$s_h$	Spacing of special lateral reinforcement (in. or mm).
$T$	The fundamental period (sec) of the <i>building</i> as determined in Sec. 5.3.3 or the modal period (sec) of the <i>building</i> modified as appropriate to account for the effective stiffness of the energy dissipation system (Sec. 13.3.2.1).
$T, T_1$	The effective fundamental period (sec) of the <i>building</i> as determined in Sec. 5.5.2.1.1 and 5.5.3.1.
$T_a$	The approximate fundamental period (sec) of the <i>building</i> as determined in Sec. 5.3.3.1.
$T_D$	Effective period, in seconds (sec), of the seismically isolated <i>structure</i> at the design <i>displacement</i> in the direction under consideration as prescribed by Eq. 13.3.3.2.
$T_p$	The fundamental period (sec) of the <i>component</i> and its attachment(s) as defined in Sec. 6.3.3.
$T_0$	$0.2S_{DI}/S_{DS}$ .
$T_S$	$S_{DI}/S_{DS}$ .
$T_M$	Effective period, in seconds (sec), of the seismically isolated <i>structure</i> at the maximum <i>displacement</i> in the direction under consideration as prescribed by Eq. 13.3.3.4.
$T_m$	The modal period of vibration (sec) of the $m^{\text{th}}$ mode of the <i>building</i> as determined in Sec. 5.4.5.
$T_4$	Net tension in steel cable due to <i>dead load</i> , <i>prestress</i> , <i>live load</i> , and seismic load (Sec. 8.5).
$t$	Specified <i>wall</i> thickness dimension or least lateral dimension of a column (in. or mm) in Chapter 11.
$t_c$	Thickness of masonry cover over reinforcing bars measured from the surface of the masonry to the surface of the reinforcing bars (in. or mm) in Chapter 11.
$V$	The total design lateral force or shear at the <i>base</i> (kip or kN).
$V$	Shear on a masonry section due to unfactored loads (lb or N) in Chapter 11.

---

$V_b$	The total lateral seismic design force or shear on <i>elements</i> of the <i>isolation system</i> or <i>elements</i> below the <i>isolation system</i> as prescribed by Eq. 13.3.4.1.
$V_m$	Shear strength provided by masonry (lb or N) in Chapter 11.
$V_n$	Nominal shear strength (lb or N) in Chapter 11.
$V_s$	The total lateral seismic design force or shear on <i>elements</i> above the <i>isolation system</i> as prescribed by Eq. 13.3.4.2.
$V_s$	Shear strength provided by shear reinforcement (lb or N) in Chapters 6 and 11.
$V_t$	The design value of the seismic <i>base shear</i> as determined in Sec. 5.4.8 (kip or N).
$V_u$	Required shear strength (lb or N) due to factored loads in Chapters 6 and 11.
$V_x$	The seismic design shear in <i>Story x</i> as determined in Sec. 5.3.5 or Sec. 5.4.8 (kip or kN).
$\bar{V}_t$	The portion of the seismic <i>base shear</i> , $\bar{V}$ , contributed by the fundamental mode, Sec. 5.5.3 (kip or kN).
$V$	The reduction in $V$ as determined in Sec. 5.5.2 (kip or kN).
$V_i$	The reduction in $V_i$ as determined in Sec. 5.5.3 (kip or kN).
$v_s$	The average shear wave velocity for the soils beneath the foundation at large strain levels, Sec. 5.5.2 (ft/s or m/s).
$\bar{v}_s$	Average shear wave velocity in top 100 ft (30 m); see Sec. 4.1.2.1.
$v_{so}$	The average shear wave velocity for the soils beneath the foundation at small strain levels, Sec. 5.5.2 (ft/s or m/s).
$W$	The total <i>gravity load</i> of the <i>building</i> as defined in Sec. 5.3.2 (kip or kN). For calculation of seismic-isolated <i>building</i> period, $W$ is the total seismic <i>dead load</i> weight of the <i>building</i> as defined in Sec. 5.5.2 and 5.5.3 (kip or kN).
$\bar{W}$	The effective <i>gravity load</i> of the <i>building</i> as defined in Sec. 5.5.2 and 5.5.3 (kip or kN).
$W_D$	The energy dissipated per cycle at the <i>story displacement</i> for the <i>design earthquake</i> (Sec. 13.3.2).
$\bar{W}_m$	The effective modal gravity load determined in accordance with Eq. 5.4.5-1 (kip or kN).
$W_p$	<i>Component</i> operating weight (lb or N).
$w$	Width of a wood <i>shear panel</i> or <i>diaphragm</i> in Chapter 9 (ft or mm).
$w$	Moisture content (in percent), ASTM D2216-92.
$w$	The dimension of a diaphragm or <i>shear wall</i> in the direction of application of force.



---

$w_i, w_x$	The portion of the total <i>gravity load</i> , $W$ , located or assigned to Level $I$ or $x$ (kip or kN).
$z$	The level under consideration; $x = 1$ designates the first level above the <i>base</i> .
$x$	Elevation in <i>structure</i> of a <i>component</i> addressed by Chapter 6.
$y$	Elevation difference between points of attachment in Chapter 6.
$y$	The distance, in feet (mm), between the center of rigidity of the <i>isolation system</i> rigidity and the <i>element</i> of interest measured perpendicular to the direction of seismic loading under consideration Chapter 13).
	The relative weight density of the <i>structure</i> and the soil as determined in Sec. 5.5.2.1.
	Angle between diagonal reinforcement and longitudinal axis of the member (degree or rad).
	Ratio of shear demand to shear capacity for the <i>story</i> between Level $x$ and $x - 1$ .
$\tilde{\phantom{D}}$	The fraction of critical damping for the coupled <i>structure</i> -foundation system, determined in Sec. 5.5.2.1.
$D$	Effective damping of the <i>isolation system</i> at the <i>design displacement</i> as prescribed by Eq. 13.9.5.2-1.
$M$	Effective damping of the <i>isolation system</i> at the maximum <i>displacement</i> as prescribed by Eq. 13.9.5.2-2.
$o$	The foundation damping factor as specified in Sec. 5.5.2.1.
$eff$	Effective damping of the <i>isolation system</i> as prescribed by Eq. 13.9.3-2.
	Lightweight concrete factor (Sec. 9.2.4.1).
	The average unit weight of soil (lb/ft <sup>3</sup> or kg/m <sup>3</sup> ).
	The design <i>story</i> drift as determined in Sec. 5.3.7.1 (in. or mm).
	The <i>displacement</i> of the dissipation device and device supports across the story (Sec. 13.3.2.1).
	Suspended ceiling lateral deflection (calculated) in Sec. 6.2.6.4.2 (in. or mm).
$a$	The allowable <i>story</i> drift as specified in Sec. 5.2.7 (in. or mm).
$m$	The design modal <i>story</i> drift determined in Sec. 5.4.6 (in. or mm)
$p$	Relative <i>displacement</i> that the <i>component</i> must be designed to accommodate as defined in Sec. 6.2.2.2 or 6.3.2.2.
$cr$	Deflection based on cracked section properties (in. or mm) in Chapter 11.
$+$	Maximum positive <i>displacement</i> of an <i>isolator unit</i> during each cycle of prototype testing.

---

-	Maximum negative <i>displacement</i> of an <i>isolator unit</i> during each cycle of prototype testing.
$max$	The maximum <i>displacement</i> at Level $x$ (in. or mm).
$avg$	The average of the <i>displacements</i> at the extreme points of the <i>structure</i> at Level $x$ (in. or mm).
$x$	The deflection of Level $x$ at the center of the mass at and above Level $x$ , Eq. 5.3.7.1 (in. or mm).
$x_e$	The deflection of Level $x$ at the center of the mass at and above Level $x$ determined by an elastic analysis, Sec. 5.3.7.1 (in. or mm).
$x_{em}$	The modal deflection of Level $x$ at the center of the mass at and above Level $x$ determined by an elastic analysis, Sec. 5.4.6 (in. or mm).
$x_m^{\sim}$	The modal deflection of Level $x$ at the center of the mass at and above Level $x$ as determined by Eq. 5.4.6-3 and 5.5.3.2-1 (in. or mm).
$x^{\sim}$	The deflection of Level $x$ at the center of the mass at and above Level $x$ , Eq. 5.5.2.3 and 5.5.3.2-1 (in. or mm).
$\epsilon_{mu}$	Maximum usable compressive strain of masonry (in./in. or mm/mm) in Chapter 11.
	The stability coefficient for <i>P-delta effects</i> as determined in Sec. 5.3.6.2.
	The overturning moment reduction factor (Sec. 5.3.6).
	A reliability coefficient based on the extent of structural redundance present in a <i>building</i> as defined in Sec. 5.2.7.
	Ratio of the area of reinforcement to the net cross sectional area of masonry in a plane perpendicular to the reinforcement in Chapter 11.
$b$	Reinforcement ratio producing balanced strain conditions in Chapter 11.
$h$	Ratio of the area of shear reinforcement to the cross sectional area of masonry in a plane perpendicular to the reinforcement in Chapter 11.
$s$	Spiral reinforcement ratio for precast prestressed piles in Sec. 7.5.3.4.
$v$	Ratio of vertical or horizontal reinforcement in <i>walls</i> (Ref. 7-2).
$x$	A reliability coefficient based on the extent of structural redundancy present in the <i>seismic-force-resisting system</i> of a <i>building</i> in the $x$ direction.
$\lambda$	Time effect factor.
$\phi$	The capacity reduction factor.
$\phi$	Strength reduction factor in Chapters 6 and 11.
$\phi$	Resistance factor for steel in Chapter 8 and wood in Chapter 12.
$\phi_{im}$	The <i>displacement</i> amplitude at the $i^{\text{th}}$ level of the <i>building</i> for the fixed base condition when vibrating in its $m^{\text{th}}$ mode, Sec. 5.4.5.

---

$o$	Overstrength factor as defined in Table 5.2.2.
	Factor of safety in Chapter 8.
$\sum E_D$	Total energy dissipated, in kip-inches (kN-mm), in the <i>isolation system</i> during a full cycle of response at the design <i>displacement</i> , $D_D$ .
$\sum E_M$	Total energy dissipated, in kip-inches (kN-mm), on the <i>isolation system</i> during a full cycle of response at the maximum <i>displacement</i> , $D_M$ .
$\sum  F_D^+ _{max}$	Sum, for all <i>isolator units</i> , of the maximum absolute value of force, in kips (kN), at a positive <i>displacement</i> equal to $D_D$ .
$\sum  F_D^+ _{min}$	Sum, for all <i>isolator units</i> , of the minimum absolute value of force, in kips (kN), at a positive <i>displacement</i> equal to $D_D$ .
$\sum  F_D^- _{max}$	Sum, for all <i>isolator units</i> , of the maximum absolute value of force, in kips (kN), at a negative <i>displacement</i> equal to $D_D$ .
$\sum  F_D^- _{min}$	Sum, for all <i>isolator units</i> , of the minimum absolute value of force, in kips (kN), at a negative <i>displacement</i> equal to $D_D$ .
$\sum  F_M^+ _{max}$	Sum, for all <i>isolator units</i> , of the maximum absolute value of force, in kips (kN), at a positive <i>displacement</i> equal to $D_M$ .
$\sum  F_M^+ _{min}$	Sum, for all <i>isolator units</i> , of the minimum absolute value of force, in kips (kN), at a positive <i>displacement</i> equal to $D_M$ .
$\sum  F_M^- _{max}$	Sum, for all <i>isolator units</i> , of the maximum absolute value of force, in kips (kN), at a negative <i>displacement</i> equal to $D_M$ .
$\sum  F_M^- _{min}$	Sum, for all <i>isolator units</i> , of the minimum absolute value of force, in kips (kN), at a negative <i>displacement</i> equal to $D_M$ .

---

## Chapter 3

### QUALITY ASSURANCE

**3.1 SCOPE:** This chapter provides minimum requirements for quality assurance for *seismic-force-resisting systems* and *designated seismic systems*. These requirements supplement the testing and inspection requirements contained in the reference standards given in Chapters 8 through 14.

**3.2 QUALITY ASSURANCE:** A *quality assurance plan* shall be submitted to the authority having jurisdiction. A *quality assurance plan*, *special inspection(s)*, and testing as set forth in this chapter shall be provided for the following:

1. The *seismic-force-resisting systems* in *structures* assigned to *Seismic Design Categories C, D, E, and F*.
2. *Designated seismic systems* in *structures* assigned to *Seismic Design Categories D, E, and F* that are required in Table 6.1.7.

**Exception:** *Structures* that comply with the following criteria are exempt from the preparation of a *quality assurance plan* but those *structures* are not exempt from *special inspection(s)* or testing requirements:

1. The *structure* is constructed of light wood framing or light gauge cold-formed steel framing,  $S_{DS}$  does not exceed 0.50g, the height of the *structure* does not exceed 35 feet above grade, and the *structure* meets the requirements in Items 3 and 4 below
- or
2. The *structure* is constructed using a reinforced masonry structural system or *reinforced concrete* structural system,  $S_{DS}$  does not exceed 0.50g, the height of the *structure* does not exceed 25 feet above grade, and the *structure* meets the requirements in Items 3 and 4 below
  3. The *structure* is classified as *Seismic Use Group I*
  4. The *structure* does not have any of the following plan irregularities as defined in Table 5.2.3.2 or any of the following vertical irregularities as defined in Table 5.2.3.3:
    - a. Torsional irregularity,
    - b. Extreme torsional irregularity,
    - c. Nonparallel systems,

- d. Stiffness irregularity -- soft *story*,
- e. Stiffness irregularity -- extreme soft *story*,
- f. Discontinuity in capacity -- weak *story*.

**3.2.1 Details of Quality Assurance Plan:** The *registered design professional* in responsible charge of the design of a *seismic-force-resisting system* and a *designated seismic system* shall be responsible for the portion of the *quality assurance plan* applicable to that system. The *quality assurance plan* shall include:

1. The *seismic-force-resisting systems* and *designated seismic systems* in accordance with this chapter that are subject to quality assurance.
2. The *special inspections* and testing to be provided as required by these *Provisions* and the reference standards in Chapters 4 through 14.
3. The type and frequency of testing.
4. The type and frequency of *special inspections*.
5. The frequency and distribution of testing and *special inspection* reports.
6. The *structural observations* to be performed.
7. The frequency and distribution of *structural observation* reports.

**3.2.2 Contractor Responsibility:** Each contractor responsible for the construction of a *seismic-force-resisting system*, *designated seismic system*, or *component* listed in the *quality assurance plan* shall submit a written contractor's statement of responsibility to the authority having jurisdiction and to the *owner* prior to the commencement of work on the system or *component*. The contractor's statement of responsibility shall contain the following:

1. Acknowledgment of awareness of the special requirements contained in the *quality assurance plan*;
2. Acknowledgment that control will be exercised to obtain conformance with the *construction documents* approved by the authority having jurisdiction;
3. Procedures for exercising control within the contractor's organization, the method and frequency of reporting, and the distribution of the reports; and
4. Identification and qualifications of the person(s) exercising such control and their position(s) in the organization.

**3.3 SPECIAL INSPECTION:** The *owner* shall employ a *special inspector(s)* to observe the construction for compliance with the following:

**3.3.1 Piers, Piles, Caissons:** *Continuous special inspection* during driving of piles and placement of concrete in piers, piles, and caissons. *Periodic special inspection* during construction of drilled piles, piers, and caissons including the placement of reinforcing steel.

**3.3.2 Reinforcing Steel:**

**3.3.2.1:** *Periodic special inspection* during and upon completion of the placement of reinforcing steel in *intermediate moment frames*, in *special moment frames*, and in *shear walls*.

**3.3.2.2:** *Continuous special inspection* during the welding of reinforcing steel resisting flexural and axial forces in *intermediate moment frames* and *special moment frames*, in *boundary members* of concrete *shear walls*, and during welding of shear reinforcement.

**3.3.3 Structural Concrete:** *Periodic special inspection* during and on completion of the placement of concrete in *intermediate moment frames*, in *special moment frames*, and in *boundary members* of *shear walls*.

**3.3.4 Prestressed Concrete:** *Periodic special inspection* during the placement and after completion of placement of prestressing steel and *continuous special inspection* is required during all stressing and grouting operations and during the placement of concrete.

**3.3.5 Structural Masonry:**

**3.3.5.1:** *Periodic special inspection* during the preparation of mortar, the laying of masonry units, and placement of reinforcement and prior to placement of grout

**3.3.5.2:** *Continuous special inspection* during the welding of reinforcement, grouting, consolidation, reconsolidation and placement of bent-bar anchors as required by Sec. 11.3.12.2.

**3.3.6 Structural Steel:**

**3.3.6.1:** *Continuous special inspection* for all structural welding.

**Exception:** *Periodic special inspection* is permitted for single-pass fillet or resistance welds and welds loaded to less than 50 percent of their *design strength* provided the qualifications of the welder and the welding electrodes are inspected at the beginning of the work and all welds are inspected for compliance with the approved *construction documents* at the completion of welding.

**3.3.6.2:** *Periodic special inspection* in accordance with Ref. 8-1 or 8-2 for installation and tightening of fully tensioned high-strength bolts in slip-critical *connections* and in *connections* subject to direct tension. Bolts in *connections* identified as not being slip-critical or subject to direct tension need not be inspected for bolt tension other than to ensure that the plies of the connected *elements* have been brought into snug contact.

**3.3.7 Structural Wood:**

**3.3.7.1:** *Continuous special inspection* during all field gluing operations of *elements* of the *seismic-force-resisting system*.

**3.3.7.2:** *Periodic special inspections* for nailing, bolting, anchoring, and other fastening of *components* within the *seismic-force-resisting system* including *drag struts*, braces, and *tie-downs*.

**3.3.8 Cold-Formed Steel Framing:**

**3.3.8.1** *Periodic special inspections* during all welding operations of *elements* of the *seismic-force-resisting system*.

**3.3.8.2** *Periodic special inspections* for screw attachment, bolting, anchoring, and other fastening of *components* within the *seismic-force-resisting system*, including struts, braces, and hold-downs.

**3.3.9 Architectural Components:** *Special inspection* for architectural *components* shall be as follows:

1. *Periodic special inspection* during the erection and fastening of exterior cladding, interior and exterior nonloadbearing *walls*, and *veneer* in *Seismic Design Categories* D, E, and F and

**Exceptions:**

- a. *Structures* 30 feet (9 m) or less in height and
  - b. Cladding and *veneer* weighing 5 lb/ft<sup>2</sup> (240 kg/m<sup>2</sup>) or less.
2. *Periodic special inspection* during the anchorage of access floors, suspended ceilings, and *storage racks* 8 feet (2.4 m) or greater in height in *Seismic Design Categories* D, E, and F.

**3.3.10 Mechanical and Electrical Components:** *Special inspection* for mechanical and electrical *components* shall be as follows:

1. *Periodic special inspection* during the anchorage of electrical equipment for emergency or standby power systems in *Seismic Design Categories* C, D, E, and F;
2. *Periodic special inspection* during the installation of anchorage of all other electrical equipment in *Seismic Design Categories* E and F;
3. *Periodic special inspection* during installation for flammable, combustible, or highly toxic piping systems and their associated mechanical units in *Seismic Design Categories* C, D, E, and F; and
4. *Periodic special inspection* during the installation of HVAC ductwork that will contain hazardous materials in *Seismic Design Categories* C, D, E, and F.

**3.3.11 Seismic Isolation System:** *Periodic special inspection* during the fabrication and installation of *isolator units* and energy dissipation devices if used as part of the *seismic isolation system*.

**3.4 TESTING:** The *special inspector(s)* shall be responsible for verifying that the testing requirements are performed by an approved *testing agency* for compliance with the following:

**3.4.1 Reinforcing and Prestressing Steel:** Special testing of reinforcing and prestressing steel shall be as follows:

**3.4.1.1:** Examine certified mill test reports for each shipment of reinforcing steel used to resist flexural and axial forces in *reinforced concrete intermediate frames*, *special moment frames*, and *boundary members* of reinforced concrete *shear walls* or reinforced masonry *shear walls* and determine conformance with the *construction documents*.

**3.4.1.2:** Where ASTM A615 reinforcing steel is used to resist earthquake-induced flexural and axial forces in *special moment frames* and in wall *boundary elements* of *shear walls* in *structures*

of *Seismic Design Categories* D, E, and F, verify that the requirements of Sec. 21.2.5.1 of Ref. 9-1 have been satisfied.

**3.4.1.3:** Where ASTM A615 reinforcing steel is to be welded, verify that chemical tests have been performed to determine weldability in accordance with Sec. 3.5.2 of Ref. 9-1.

**3.4.2 Structural Concrete:** Samples of structural concrete shall be obtained at the project site and tested in accordance with requirements of Ref. 9-1

**3.4.3 Structural Masonry:** Quality assurance testing of structural masonry shall be in accordance with the requirements of Ref. 11-1.

**3.4.4 Structural Steel:** The testing needed to establish that the construction is in conformance with these *Provisions* shall be included in a *quality assurance plan*. The minimum testing contained in the *quality assurance plan* shall be as required in Ref. 8-3 and the following requirements:

**3.4.4.1 Base Metal Testing:** Base metal thicker than 1.5 in. (38 mm), when subject to through-thickness weld shrinkage strains, shall be ultrasonically tested for discontinuities behind and adjacent to such welds after joint completion. Any material discontinuities shall be accepted or rejected on the basis of ASTM A435, *Specification for Straight Beam Ultrasound Examination of Steel Plates*, or ASTM A898, *Specification for Straight Beam Ultrasound Examination for Rolled Steel Shapes*, (Level 1 Criteria) and criteria as established by the *registered design professional(s)* in responsible charge and the *construction documents*.

**3.4.5 Mechanical and Electrical Equipment:** As required to ensure compliance with the seismic design requirements herein, the *registered design professional* in responsible charge shall clearly state the applicable requirements on the *construction documents*. Each manufacturer of *designated seismic system components* shall test or analyze the *component* and its mounting system or anchorage as required and shall submit evidence of compliance for review and acceptance by the *registered design professional* in responsible charge of the *designated seismic system* and for approval by the authority having jurisdiction. The evidence of compliance shall be by actual test on a shake table, by three-dimensional shock tests, by an analytical method using dynamic characteristics and forces, by the use of experience data (i.e., historical data demonstrating acceptable seismic performance), or by more rigorous analysis providing for equivalent safety. The *special inspector* shall examine the *designated seismic system* and shall determine whether the anchorages and label conform with the evidence of compliance.

**3.4.6 Seismically Isolated Structures:** For required system tests, see Sec. 13.9.

**3.5 STRUCTURAL OBSERVATIONS:** *Structural observations* shall be provided for those *structures* included in *Seismic Design Categories* D, E, and F when one or more of the following conditions exist:

1. The *structure* is included in *Seismic Use Group* II or *Seismic Use Group* III or
2. The height of the *structure* is greater than 75 feet above the *base* or
3. The *structure* is in *Seismic Design Category* E or F and *Seismic Use Group* I and is greater than two *stories* in height.



Observed deficiencies shall be reported in writing to the *owner* and the authority having jurisdiction.

**3.6 REPORTING AND COMPLIANCE PROCEDURES:** Each *special inspector* shall furnish to the authority having jurisdiction, *registered design professional* in responsible charge, the *owner*, the persons preparing the *quality assurance plan*, and the contractor copies of regular progress reports of the inspector's observations, noting therein any uncorrected deficiencies and corrections made to previously reported deficiencies. All deficiencies shall be brought to the immediate attention of the contractor for correction.

At completion of construction, each *special inspector* shall submit a final report to the authority having jurisdiction certifying that all inspected work was completed substantially in accordance with the approved *construction documents*. Work not in compliance with the approved *construction documents* shall be described in the final report.

At completion of construction, the contractor shall submit a final report to the authority having jurisdiction certifying that all construction work incorporated into the *seismic-force-resisting system* and other *designated seismic systems* was constructed substantially in accordance with the approved *construction documents* and applicable workmanship requirements. Work not in compliance with the approved *construction documents* shall be described in the final report.

The contractor shall correct all deficiencies as required.

## Chapter 4

### GROUND MOTION

#### **4.1 PROCEDURES FOR DETERMINING MAXIMUM CONSIDERED EARTHQUAKE AND DESIGN EARTHQUAKE GROUND MOTION ACCELERATIONS AND RESPONSE SPECTRA:**

Ground motion accelerations, represented by response spectra and coefficients derived from these spectra, shall be determined in accordance with the general procedure of Sec. 4.1.2 or the site-specific procedure of Sec. 4.1.3. The general procedure in which spectral response acceleration parameters for the *maximum considered earthquake ground motions* are derived using Maps 1 through 24, modified by site coefficients to include local site effects and scaled to design values, are permitted to be used for any *structure* except as specifically indicated in these *Provisions*. The site-specific procedure also is permitted to be used for any *structure* and shall be used where specifically required by these *Provisions*.

**4.1.1 Maximum Considered Earthquake Ground Motions:** The *maximum considered earthquake ground motions* shall be as represented by the mapped spectral response acceleration at short periods,  $S_s$ , and at 1 second,  $S_1$ , obtained from Maps 1 through 24 of these *Provisions*, respectively, and adjusted for *Site Class* effects using the site coefficients of Sec. 4.1.2.4. When a site-specific procedure is used, *maximum considered earthquake ground motion* shall be determined in accordance with Sec. 4.1.3.

**4.1.2 General Procedure for Determining Maximum Considered Earthquake and Design Spectral Response Accelerations:** The mapped *maximum considered earthquake* spectral response acceleration at short periods ( $S_s$ ) and at 1 second ( $S_1$ ) shall be determined respectively from Spectral Acceleration Maps 1 through 24.

For *structures* located within those regions of the maps having values of the short period spectral response acceleration,  $S_s$ , less than or equal to 0.15g and values of the 1 second period spectral response acceleration,  $S_1$ , less than or equal to 0.04g, accelerations need not be determined. Such *structures* are permitted to be directly categorized as *Seismic Design Category A* in accordance with Sec. 4.2.1.

For all other *structures*, the *Site Class* shall be determined in accordance with Sec. 4.1.2.1. The *maximum considered earthquake* spectral response accelerations adjusted for *Site Class* effects,  $S_{MS}$  and  $S_{MI}$  shall be determined in accordance with Sec. 4.1.2.4 and the design spectral response accelerations,  $S_{DS}$  and  $S_{DI}$ , shall be determined in accordance with Sec. 4.1.2.5. The general response spectrum, when required by these *Provisions*, shall be determined in accordance with Sec. 4.1.2.6.

**4.1.2.1 Site Class Definitions:** For all *structures* located within those regions of the maps having values of the short period spectral response acceleration,  $S_s$ , greater than 0.15g or values of the 1 second period spectral response acceleration,  $S_1$ , greater than 0.04g, the site shall be classified as one of the following classes:

- A Hard rock with measured shear wave velocity,  $\bar{v}_s > 5,000$  ft/sec (1500 m/s)
- B Rock with  $2,500$  ft/sec  $< \bar{v}_s \leq 5,000$  ft/sec ( $760$  m/s  $< \bar{v}_s \leq 1500$  m/s)
- C Very dense soil and soft rock with  $1,200$  ft/sec  $< \bar{v}_s \leq 2,500$  ft/sec ( $360$  m/s  $< \bar{v}_s \leq 760$  m/s) or with either  $N > 50$  or  $\bar{s}_u > 2,000$  psf (100 kPa)
- D Stiff soil with  $600$  ft/sec  $\leq \bar{v}_s \leq 1,200$  ft/sec ( $180$  m/s  $\leq \bar{v}_s \leq 360$  m/s) or with either  $15 \leq N \leq 50$  or  $1,000$  psf  $\leq \bar{s}_u \leq 2,000$  psf ( $50$  kPa  $\leq \bar{s}_u \leq 100$  kPa)
- E A soil profile with  $\bar{v}_s < 600$  ft/sec (180 m/s) or with either  
 $N < 15$   $\bar{s}_u < 1,000$  psf or any profile with more than 10 ft (3 m) of soft clay defined as soil with  $PI > 20$ ,  $w \geq 40$  percent, and  $s_u < 500$  psf (25 kPa)
- F Soils requiring site-specific evaluations:
  - 1. Soils vulnerable to potential failure or collapse under seismic loading such as liquefiable soils, quick and highly sensitive clays, collapsible weakly cemented soils.
  - 2. Peats and/or highly organic clays ( $H > 10$  ft [3 m] of peat and/or highly organic clay where  $H$  = thickness of soil)
  - 3. Very high plasticity clays ( $H > 25$  ft [8 m] with  $PI > 75$ )
  - 4. Very thick soft/medium stiff clays ( $H > 120$  ft [36 m])

**Exception:** When the soil properties are not known in sufficient detail to determine the *Site Class*, *Site Class D* shall be used. *Site Classes E* or *F* need not be assumed unless the authority having jurisdiction determines that *Site Classes E* or *F* could be present at the site or in the event that *Site Classes E* or *F* are established by geotechnical data.

#### 4.1.2.2 Steps for Classifying a Site (also see Table 4.1.2.2 below):

- Step 1:** Check for the four categories of *Site Class F* requiring site-specific evaluation. If the site corresponds to any of these categories, classify the site as *Site Class F* and conduct a site-specific evaluation.
- Step 2:** Check for the existence of a total thickness of soft clay  $> 10$  ft (3 m) where a soft clay layer is defined by:  $s_u < 500$  psf (25 kPa),  $w \geq 40$  percent, and  $PI > 20$ . If these criteria are satisfied, classify the site as *Site Class E*.
- Step 3:** Categorize the site using one of the following three methods with  $\bar{v}_s$ ,  $N$ , and  $\bar{s}_u$  computed in all cases as specified by the definitions in Sec. 4.1.2.2:
  - a.  $\bar{v}_s$  for the top 100 ft (30 m) ( $\bar{v}_s$  method)
  - b.  $N$  for the top 100 ft (30 m) ( $N$  method)
  - c.  $N_{ch}$  for cohesionless soil layers ( $PI < 20$ ) in the top 100 ft (30 m) and average  $\bar{s}_u$  for cohesive soil layers ( $PI > 20$ ) in the top 100 ft (30 m) ( $\bar{s}_u$  method)

**TABLE 4.1.2.2 Site Classification**

<i>Site Class</i>	$\bar{v}_s$	$N$ or $N_{ch}$	$\bar{s}_u$
E	< 600 fps ( < 180 m/s)	< 15	< 1,000 psf ( < 50 kPa)
D	600 to 1,200 fps (180 to 360 m/s)	15 to 50	1,000 to 2,000 psf (50 to 100 kPa)
C	> 1,200 to 2,500 fps (360 to 760 m/s)	> 50	> 2,000 ( > 100 kPa)

NOTE: If the  $\bar{s}_u$  method is used and the  $N_{ch}$  and  $\bar{s}_u$  criteria differ, select the category with the softer soils (for example, use *Site Class* E instead of D).

The shear wave velocity for rock, *Site Class* B, shall be either measured on site or estimated for competent rock with moderate fracturing and weathering. Softer and more highly fractured and weathered rock shall either be measured on site for shear wave velocity or classified as *Site Class* C.

The hard rock, *Site Class* A, category shall be supported by shear wave velocity measurements either on site or on profiles of the same rock type in the same formation with an equal or greater degree of weathering and fracturing. Where hard rock conditions are known to be continuous to a depth of 100 ft (30 m), surficial shear wave velocity measurements may be extrapolated to assess  $\bar{v}_s$ .

The rock categories, *Site Classes* A and B, shall not be used if there is more than 10 ft (3 m) of soil between the rock surface and the bottom of the spread footing or mat foundation.

**4.1.2.3 Definitions of Site Class Parameters:** The definitions presented below apply to the upper 100 ft (30 m) of the site profile. Profiles containing distinctly different soil layers shall be subdivided into those layers designated by a number that ranges from 1 to  $n$  at the bottom where there are a total of  $n$  distinct layers in the upper 100 ft (30 m). The symbol  $I$  then refers to any one of the layers between 1 and  $n$ .

$v_{si}$  is the shear wave velocity in ft/sec (m/s).

$d_i$  is the thickness of any layer between 0 and 100 ft (30 m).

$\bar{v}_s$  is:

$$\bar{v}_s = \frac{\sum_{i=1}^n d_i}{\sum_{i=1}^n \frac{d_i}{v_{si}}} \quad (4.1.2.3-1)$$

where  $\sum_{i=1}^n d_i$  is equal to 100 ft (30 m)

$N_i$  is the Standard Penetration Resistance (ASTM D1586-84) not to exceed 100 blows/ft as directly measured in the field without corrections.

$\bar{N}$  is:

$$\bar{N} = \frac{\sum_{i=1}^n d_i}{\sum_{i=1}^n \frac{d_i}{N_i}} \quad (4.1.2.3-2)$$

$N_{ch}$  is:

$$\bar{N}_{ch} = \frac{d_s}{\sum_{i=1}^m \frac{d_i}{N_i}} \quad (4.1.2.3-3)$$

where  $\sum_{i=1}^m d_i = d_s$ .

(Use only  $d_i$  and  $N_i$  for cohesionless soils.)

$d_s$  is the total thickness of cohesionless soil layers in the top 100 ft (30 m).

$s_{ui}$  is the undrained shear strength in psf (kPa), not to exceed 5,000 psf (250 kPa), ASTM D2166-91 or D2850-87.

$\bar{s}_u$  is:

$$\bar{s}_u = \frac{d_c}{\sum_{i=1}^k \frac{d_i}{s_{ui}}} \quad (4.1.2.3-3)$$

where  $\sum_{i=1}^k d_i = d_c$ .

$d_c$  is the total thickness (100 -  $d_s$ ) of cohesive soil layers in the top 100 ft (30 m).

$PI$  is the plasticity index, ASTM D4318-93.

$w$  is the moisture content in percent, ASTM D2216-92.

**4.1.2.4 Site Coefficients and Adjusted Maximum Considered Earthquake Spectral Response Acceleration Parameters:** The *maximum considered earthquake* spectral response

acceleration for short periods ( $S_{MS}$ ) and at 1 second ( $S_{MI}$ ), adjusted for *site class* effects, shall be determined by Eq. 4.1.2.4-1 and 4.1.2.4-2, respectively:

$$S_{MS} = F_a S_S \quad (4.1.2.4-1)$$

and

$$S_{MI} = F_v S_1 \quad (4.1.2.4-2)$$

where *site coefficients*  $F_a$  and  $F_v$  are defined in Tables 4.1.2.4a and b, respectively.

**TABLE 4.1.2.4a Values of  $F_a$  as a Function of Site Class and Mapped Short-Period Maximum Considered Earthquake Spectral Acceleration**

Site Class	Mapped Maximum Considered Earthquake Spectral Response Acceleration at Short Periods				
	$S_S \leq 0.25$	$S_S = 0.50$	$S_S = 0.75$	$S_S = 1.00$	$S_S \geq 1.25$
A	0.8	0.8	0.8	0.8	0.8
B	1.0	1.0	1.0	1.0	1.0
C	1.2	1.2	1.1	1.0	1.0
D	1.6	1.4	1.2	1.1	1.0
E	2.5	1.7	1.2	0.9	<i>a</i>
F	<i>a</i>	<i>a</i>	<i>a</i>	<i>a</i>	<i>a</i>

NOTE: Use straight line interpolation for intermediate values of  $S_S$ .

<sup>a</sup> Site-specific geotechnical investigation and dynamic site response analyses shall be performed.

**TABLE 4.1.2.4b Values of  $F_v$  as a Function of Site Class and Mapped 1 Second Period Maximum Considered Earthquake Spectral Acceleration**

Site Class	Mapped Maximum Considered Earthquake Spectral Response Acceleration at 1 Second Periods				
	$S_I \leq 0.1$	$S_I = 0.2$	$S_I = 0.3$	$S_I = 0.4$	$S_I \geq 0.5$
A	0.8	0.8	0.8	0.8	0.8
B	1.0	1.0	1.0	1.0	1.0
C	1.7	1.6	1.5	1.4	1.3
D	2.4	2.0	1.8	1.6	1.5
E	3.5	3.2	2.8	2.4	<i>a</i>
F	<i>a</i>	<i>a</i>	<i>a</i>	<i>a</i>	<i>a</i>

NOTE: Use straight line interpolation for intermediate values of  $S_I$ .

<sup>a</sup> Site-specific geotechnical investigation and dynamic site response analyses shall be performed.

**4.1.2.5 Design Spectral Response Acceleration Parameters:** *Design earthquake* spectral response acceleration at short periods,  $S_{DS}$ , and at 1 second period,  $S_{D1}$ , shall be determined from Eq. 4.1.2.5-1 and 4.1.2.5-2, respectively:

$$S_{DS} = \frac{2}{3} S_{MS} \quad (4.1.2.5-1)$$

and

$$S_{D1} = \frac{2}{3} S_{M1} \quad (4.1.2.5-2)$$

**4.1.2.6 General Procedure Response Spectrum:** Where a design response spectrum is required by these *Provisions* and site-specific procedures are not used, the design response spectrum curve shall be developed as indicated in Figure 4.1.2.6 and as follows:

1. For periods less than or equal to  $T_0$ , the design spectral response acceleration,  $S_a$ , shall be taken as given by Eq. 4.1.2.6-1:

$$S_a = 0.6 \frac{S_{DS}}{T_0} T + 0.4 S_{DS} \quad (4.1.2.6-1)$$

2. For periods greater than or equal to  $T_0$  and less than or equal to  $T_s$ , the design spectral response acceleration,  $S_a$ , shall be taken as equal to  $S_{DS}$ .
3. For periods greater than  $T_s$ , the design spectral response acceleration,  $S_a$ , shall be taken as given by Eq. 4.1.2.6-3:

$$S_a = \frac{S_{D1}}{T} \quad (4.1.2.6-3)$$

where:

- $S_{DS}$  = the design spectral response acceleration at short periods;
- $S_{D1}$  = the design spectral response acceleration at 1 second period;
- $T$  = the fundamental period of the *structure* (sec);
- $T_0$  =  $0.2 S_{D1} / S_{DS}$ ; and
- $T_s$  =  $S_{D1} / S_{DS}$ .

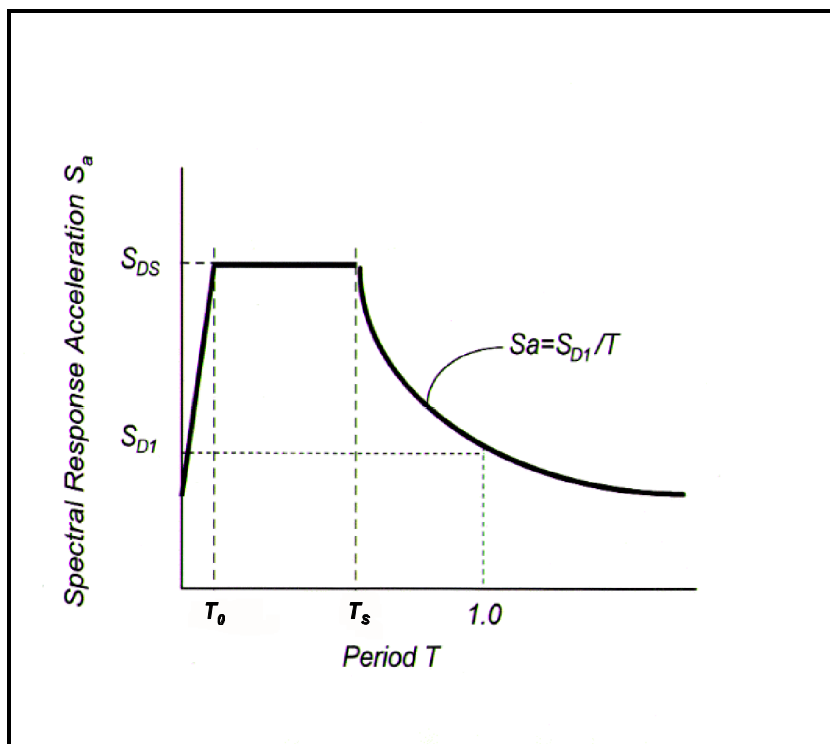

FIGURE 4.1.2.6 Design response spectrum.

**4.1.3 Site-Specific Procedure for Determining Ground Motion Accelerations:** A site-specific study shall account for the regional seismicity and geology, the expected recurrence rates and maximum magnitudes of events on known faults and source zones, the location of the site with respect to these, near source effects if any, and the characteristics of subsurface site conditions.

**4.1.3.1 Probabilistic Maximum Considered Earthquake:** When site-specific procedures are utilized, the *maximum considered earthquake ground motion* shall be taken as that motion represented by a 5 percent damped acceleration response spectrum having a 2 percent probability of exceedance within a 50 year period. The *maximum considered earthquake* spectral response acceleration,  $S_{aM}$ , at any period,  $T$ , shall be taken from that spectrum.

**Exception:** Where the spectral response ordinates for a 5 percent damped spectrum having a 2 percent probability of exceedance within a 50 year period at periods of 0.2 second or 1 second exceed the corresponding ordinate of the deterministic limit of Sec. 4.1.3.2, the *maximum considered earthquake ground motion* shall be taken as the lesser of the probabilistic *maximum considered earthquake ground motion* or the deterministic *maximum considered earthquake ground motion* of Sec. 4.1.3.3 but shall not be taken less than the deterministic limit ground motion of Sec. 4.1.3.2.

**4.1.3.2 Deterministic Limit on Maximum Considered Earthquake Ground Motion:** The deterministic limit on *maximum considered earthquake ground motion* shall be taken as the response spectrum determined in accordance with Figure 4.1.3.2, where  $F_a$  and  $F_v$  are determined in accordance with Sec. 4.1.2.4, with the value of  $S_s$  taken as 1.5g and the value of  $S_l$  taken as 0.6g.



**4.1.3.3 Deterministic Maximum Considered Earthquake Ground Motion:** The deterministic *maximum considered earthquake ground motion* response spectrum shall be calculated as 150 percent of the median 5 percent damped spectral response accelerations ( $S_{aM}$ ) at all periods resulting from a characteristic earthquake on any known active fault within the region.

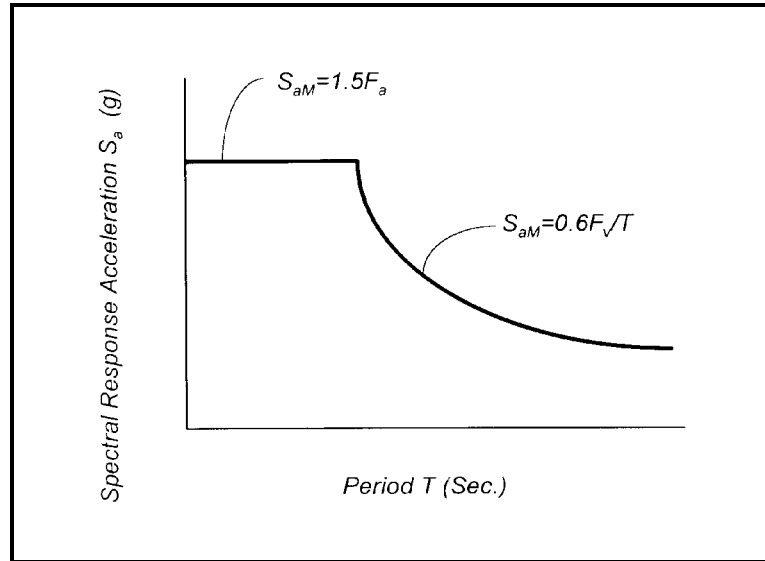

**FIGURE 4.1.3.2** Deterministic limit on maximum considered earthquake response spectrum.

**4.1.3.5 Site-Specific Design Ground Motion:** Where site-specific procedures are used to determine the *maximum considered earthquake ground motion* response spectrum, the design spectral response acceleration at any period shall be determined from Eq. 4.1.3.5:

$$S_a = \frac{2}{3} S_{aM} \quad (4.1.3.5)$$

and shall be greater than or equal to 80 percent of the  $S_a$  determined by the general response spectrum in Sec. 4.1.2.6.

**4.2 SEISMIC DESIGN CATEGORY:** Each *structure* shall be assigned a *Seismic Design Category* in accordance with Sec. 4.2.1. *Seismic Design Categories* are used in these *Provisions* to determine permissible structural systems, limitations on height and irregularity, those components of the *structure* that must be designed for seismic resistance, and the types of lateral force analysis that must be performed.

**4.2.1 Determination of Seismic Design Category:** All *structures* shall be assigned to a *Seismic Design Category* based on their *Seismic Use Group* and the design spectral response acceleration coefficients,  $S_{DS}$  and  $S_{DI}$ , determined in accordance with Sec. 4.1.2.5. Each *building* and *structure* shall be assigned to the most severe *Seismic Design Category* in accordance with Table 4.2.1a or 4.2.1b, irrespective of the fundamental period of vibration of the *structure*,  $T$ .

**TABLE 4.2.1a Seismic Design Category Based on Short Period Response Accelerations**

Value of $S_{DS}$	Seismic Use Group		
	I	II	III
$S_{DS} < 0.167g$	A	A	A
$0.167g \leq S_{DS} < 0.33g$	B	B	C
$0.33g \leq S_{DS} < 0.50g$	C	C	D
$0.50g \leq S_{DS}$	D <sup>a</sup>	D <sup>a</sup>	D <sup>a</sup>

<sup>a</sup> See footnote on Table 4.2.1b.

**TABLE 4.2.1b Seismic Design Category Based on 1 Second Period Response Accelerations**

Value of $S_{D1}$	Seismic Use Group		
	I	II	III
$S_{D1} < 0.067g$	A	A	A
$0.067g \leq S_{D1} < 0.133g$	B	B	C
$0.133g \leq S_{D1} < 0.20g$	C	C	D
$0.20g \leq S_{D1}$	D <sup>a</sup>	D <sup>a</sup>	D <sup>a</sup>

<sup>a</sup> Seismic Use Group I and II structures located on sites with mapped maximum considered earthquake spectral response acceleration at 1 second period,  $S_1$ , equal to or greater than 0.75g shall be assigned to Seismic Design Category E and Seismic Use Group III structures located on such sites shall be assigned to Seismic Design Category F.

**4.2.2 Site Limitation for Seismic Design Categories E and F:** A structure assigned to Seismic Design Category E or F shall not be sited where there is the potential for an active fault to cause rupture of the ground surface at the structure.

**Exception:** Detached one- and two-family dwellings of light-frame construction.

## Chapter 5

### STRUCTURAL DESIGN CRITERIA

#### 5.1 REFERENCE DOCUMENT:

The following reference document shall be used for loads other than earthquakes and for combinations of loads as indicated in this chapter:

Ref. 5-1      *Minimum Design Loads for Buildings and Other Structures*, ASCE 7-95

#### 5.2 DESIGN BASIS:

**5.2.1 General:** The seismic analysis and design procedures to be used in the design of *buildings* and other *structures* and their *components* shall be as prescribed in this chapter. The *structure* shall include complete lateral and vertical-force-resisting systems capable of providing adequate *strength*, stiffness, and energy dissipation capacity to withstand the design ground motions within the prescribed limits of *deformation* and *strength* demand. The design ground motions shall be assumed to occur along any direction of the *structure*. The adequacy of the structural systems shall be demonstrated through construction of a mathematical model and evaluation of this model for the effects of the design ground motions. Unless otherwise required, this evaluation shall consist of a linear elastic analysis in which design *seismic forces* are distributed and applied throughout the height of the *structure* in accordance with the procedures in Sec. 5.3 or Sec. 5.4. The corresponding structural *deformations* and internal forces in all members of the *structure* shall be determined and evaluated against acceptance criteria contained in these *Provisions*. Approved alternative procedure based on general principles of engineering mechanics and dynamics are permitted to be used to establish the *seismic forces* and their distribution. If an alternative procedure is used, the corresponding internal forces and *deformations* in the members shall be determined using a model consistent with the procedure adopted.

Individual members shall be provided with adequate *strength* to resist the shears, axial forces, and moments determined in accordance with these *Provisions*, and connections shall develop the *strength* of the connected members or the forces indicated above. The *deformation* of the *structure* shall not exceed the prescribed limits.

A continuous load path, or paths, with adequate *strength* and stiffness shall be provided to transfer all forces from the point of application to the final point of resistance. The foundation shall be designed to accommodate the forces developed or the movements imparted to the *structure* by the design ground motions. In the determination of the foundation design criteria, special recognition shall be given to the dynamic nature of the forces, the expected ground motions, and the design basis for *strength* and energy dissipation capacity of the *structure*.

**5.2.2 Basic Seismic-Force-Resisting Systems:** The basic lateral and vertical *seismic-force-resisting system* shall conform to one of the types indicated in Table 5.2.2 subject to the limitations on height based on *Seismic Design Category* indicated in the table. Each type is subdivided by the types of vertical *element* used to resist lateral *seismic forces*. The appropriate response modification coefficient,  $R$ ; system overstrength factor,  $\phi$ , and deflection amplification factor,  $C_d$ , indicated in Table 5.2.2 shall be used in determining the *base shear*, *element* design forces, and design *story drift* as indicated in these *Provisions*.

*Seismic-force-resisting systems* that are not contained in Table 5.2.2 shall be permitted if analytical and test data are submitted that establish the dynamic characteristics and demonstrate the lateral force resistance and energy dissipation capacity to be equivalent to the structural systems listed in Table 5.2.2 for equivalent response modification coefficient,  $R$ ; system overstrength coefficient,  $\phi$ , and deflection amplification factor,  $C_d$ , values.

Special framing requirements are indicated in Sec. 5.2.6 and in Chapters 8, 9, 10, 11, and 12 for *structures* assigned to the various *Seismic Design Categories*.

**5.2.2.1 Dual System:** For a dual system, the *moment frame* shall be capable of resisting at least 25 percent of the design forces. The total seismic force resistance is to be provided by the combination of the *moment frame* and the *shear walls* or *braced frames* in proportion to their rigidities.

**5.2.2.2 Combinations of Framing Systems:** Different *seismic-force-resisting systems* are permitted along the two orthogonal axes of the *structure*. Combinations of *seismic-force-resisting systems* shall comply with the requirements of this section.

**5.2.2.2.1  $R$  and  $\phi$  Factors:** The response modification coefficient,  $R$ , in the direction under consideration at any *story* shall not exceed the lowest response modification factor,  $R$ , for the *seismic-force-resisting system* in the same direction considered above that *story* excluding penthouses. For other than dual systems where a combination of different structural systems is utilized to resist lateral forces in the same direction, the value of  $R$  used in that direction shall not be greater than the least value of any of the systems utilized in the same direction. If a system other than a dual system with a response modification coefficient,  $R$ , with a value of less than 5 is used as part of the *seismic-force-resisting system* in any direction of the *structure*, the lowest such value shall be used for the entire *structure*. The system overstrength factor,  $\phi$ , in the direction under consideration at any *story* shall not be less than the largest value of this factor for the *seismic-force-resisting system* in the same direction considered above that *story*.

**Exceptions:**

1. Supported structural systems with a weight equal to or less than 10 percent of the weight of the *structure*.
2. Detached one- and two-family dwellings of light-frame construction.

**5.2.2.2.2 Combination Framing Detailing Requirements:** The detailing requirements of Sec. 5.2.6 required by the higher response modification coefficient,  $R$ , shall be used for structural *components* common to systems having different response modification coefficients.

**5.2.2.3 Seismic Design Categories B and C:** The structural framing system for *structures* assigned to *Seismic Design Categories* B and C shall comply with the *structure* height and structural limitations in Table 5.2.2.

**Table 5.2.2 Design Coefficients and Factors for Basic Seismic-Force-Resisting Systems**

Basic Seismic-Force-Resisting System	Detailing Reference Section	Response Modification Coefficient, $R^a$	System Over-strength Factor, $\phi^g$	Deflection Amplification Factor, $C_d^b$	System Limitations and Building Height Limitations (ft) by Seismic Design Category <sup>c</sup>				
					B	C	D <sup>d</sup>	E <sup>e</sup>	F <sup>e</sup>
<b>Bearing Wall Systems</b>									
Ordinary steel concentrically braced frames	Ref. 8-3, Part I, Sec. 11	4	2	3½	NL	NL	160	160	160
Special reinforced concrete shear walls	9.3.2.4	5	2½	5	NL	NL	160	160	100
Ordinary reinforced concrete shear walls	9.3.2.3	4	2½	4	NL	NL	NP	NP	NP
Detailed plain concrete shear walls	9.3.2.2	2½	2½	2	NL	NL	NP	NP	NP
Ordinary plain concrete shear walls	9.3.2.1	1½	2½	1½	NL	NP	NP	NP	NP
Special reinforced masonry shear walls	11.11.5	3½	2½	3½	NL	NL	160	160	100
Intermediate reinforced masonry shear walls	11.11.4	2½	2½	2-1/4	NL	NL	NP	NP	NP
Ordinary reinforced masonry shear walls	11.11.3	2	2½	1-3/4	NL	NP	NP	NP	NP
Detailed plain masonry shear walls	11.11.2	2	2½	1-3/4	NL	160	NP	NP	NP
Ordinary plain masonry shear walls	11.11.1	1½	2½	1-1/4	NL	NP	NP	NP	NP
Light frame walls with shear panels	8.6, 12.3.4, 12.4	6½	3	4	NL	NL	65	65	65
<b>Building Frame Systems</b>									
Steel eccentrically braced frames, moment resisting, connections at columns away from links	Ref. 8-3, Part I, Sec. 15	8	2	4	NL	NL	160	160	100
Steel eccentrically braced frames, nonmoment resisting, connections at columns away from links	Ref. 8-3, Part I, Sec. 15	7	2	4	NL	NL	160	160	100
Special steel concentrically braced frames	Ref. 8-3, Part I, Sec. 13	6	2	5	NL	NL	160	160	100

Basic Seismic-Force-Resisting System	Detailing Reference Section	Response Modification Coefficient, $R^a$	System Over-strength Factor, $\phi^g$	Deflection Amplification Factor, $C_d^b$	System Limitations and Building Height Limitations (ft) by Seismic Design Category <sup>c</sup>				
					B	C	D <sup>d</sup>	E <sup>e</sup>	F <sup>e</sup>
Ordinary steel concentrically braced frames	Ref. 8-3, Part I, Sec. 14	5	2	4½	NL	NL	160	100	100
Special reinforced concrete shear walls	9.3.2.4	6	2½	5	NL	NL	160	160	100
Ordinary reinforced concrete shear walls	9.3.2.3	5	2½	4½	NL	NL	NP	NP	NP
Detailed plain concrete shear walls	9.3.2.2	3	2½	2½	NL	NL	NP	NP	NP
Ordinary plain concrete shear walls	9.3.2.1	2	2½	2	NL	NP	NP	NP	NP
Composite eccentrically braced frames	Ref. 8-3, Part II, Sec. 14	8	2	4	NL	NL	160	160	100
Composite concentrically braced frames	Ref. 8-3, Part II, Sec. 13	5	2	4½	NL	NL	160	160	100
Ordinary composite braced frames	Ref. 8-3, Part II, Sec. 12	3	2	3	NL	NL	NP	NP	NP
Composite steel plate shear walls	Ref. 8-3, Part II, Sec. 17	6½	2½	5½	NL	NL	160	160	100
Special composite reinforced concrete shear walls with steel elements	Ref. 8-3, Part II, Sec. 16	6	2½	5	NL	NL	160	160	100
Ordinary composite reinforced concrete shear walls with steel elements	Ref. 8-3, Part II, Sec. 15	5	2½	4½	NL	NL	NP	NP	NP
Special reinforced masonry shear walls	11.11.5	4½	2½	4	NL	NL	160	160	100
Intermediate reinforced masonry shear walls	11.11.4	3	2½	2½	NL	NL	160	160	100
Ordinary reinforced masonry shear walls	11.11.3	2½	2½	2¼	NL	NP	NP	NP	NP
Detailed plain masonry shear walls	11.11.2	2½	2½	2¼	NL	160	NP	NP	NP
Ordinary plain masonry shear walls	11.11.1	1½	2½	1¼	NL	NP	NP	NP	NP
Light frame walls with shear panels	8.6, 12.3.4, 12.4	7	2½	4½	NL	NL	160	160	160

Basic Seismic-Force-Resisting System	Detailing Reference Section	Response Modification Coefficient, $R^a$	System Overstrength Factor, $\theta^g$	Deflection Amplification Factor, $C_d^b$	System Limitations and Building Height Limitations (ft) by Seismic Design Category <sup>c</sup>				
					B	C	D <sup>d</sup>	E <sup>e</sup>	F <sup>e</sup>
<b>Moment Resisting Frame Systems</b>									
<i>Special steel moment frames</i>	Ref. 8-3, Part I, Sec. 9	8	3	5½	NL	NL	NL	NL	NL
<i>Special steel truss moment frames</i>	Ref. 8-3, Part I, Sec. 12	7	3	5-1/2	NL	NL	160	100	NP
<i>Intermediate steel moment frames</i>	Ref. 8-3, Part I, Sec. 10	6	3	5	NL	NL	160	100	NP <sup>l</sup>
<i>Ordinary steel moment frames</i>	Ref. 8-3, Part I, Sec. 11	4	3	3½	NL	NL	35 <sup>l</sup>	NP <sup>ij</sup>	NP <sup>ij</sup>
<i>Special reinforced concrete moment frames</i>	9.3.1.3	8	3	5½	NL	NL	NL	NL	NL
<i>Intermediate reinforced concrete moment frames</i>	9.3.1.2	5	3	4½	NL	NL	NP	NP	NP
<i>Ordinary reinforced concrete moment frames</i>	9.3.1.1	3	3	2½	NL <sup>h</sup>	NP	NP	NP	NP
<i>Special composite moment frames</i>	Ref. 8-3, Part II, Sec. 9	8	3	5½	NL	NL	NL	NL	NL
<i>Intermediate composite moment frames</i>	Ref. 8-3, Part II, Sec. 10	5	3	4½	NL	NL	NP	NP	NP
<i>Composite partially restrained moment frames</i>	Ref. 8-3, Part II, Sec. 8	6	3	5½	160	160	100	NP	NP
<i>Ordinary composite moment frames</i>	Ref. 8-3, Part II, Sec. 11	3	3	2½	NL	NP	NP	NP	NP
<i>Special masonry moment frames</i>	11.2	5½	3	5	NL	NL	160	160	100

Basic Seismic-Force-Resisting System	Detailing Reference Section	Response Modification Coefficient, $R^a$	System Over-strength Factor, $\phi^g$	Deflection Amplification Factor, $C_d^b$	System Limitations and Building Height Limitations (ft) by Seismic Design Category <sup>c</sup>				
					B	C	D <sup>d</sup>	E <sup>e</sup>	F <sup>e</sup>
<b>Dual Systems with Special Moment Frames Capable of Resisting at Least 25% of Prescribed Seismic Forces</b>									
Steel <i>eccentrically braced frames</i> , moment resisting connections, at columns away from links	Ref. 8-3, Part I, Sec. 15	8	2½	4	NL	NL	NL	NL	NL
Steel <i>eccentrically braced frames</i> , non-moment resisting connections, at columns away from links	Ref. 8-3, Part I, Sec. 15	7	2½	4	NL	NL	NL	NL	NL
<i>Special steel concentrically braced frames</i>	Ref. 8-3, Part I, Sec. 13	8	2½	6½	NL	NL	NL	NL	NL
<i>Ordinary steel concentrically braced frames</i>	Ref. 8-3, Part I, Sec. 14	6	2½	5	NL	NL	NL	NL	NL
<i>Special reinforced concrete shear walls</i>	9.3.2.4	8	2½	6½	NL	NL	NL	NL	NL
<i>Ordinary reinforced concrete shear walls</i>	9.3.2.3	7	2½	6	NL	NL	NP	NP	NP
<i>Composite eccentrically braced frames</i>	Ref. 8-3, Part II, Sec. 14	8	2½	4	NL	NL	NL	NL	NL
<i>Composite concentrically braced frames</i>	Ref. 8-3, Part II, Sec. 13	6	2½	5	NL	NL	NL	NL	NL
<i>Composite steel plate shear walls</i>	Ref. 8-3, Part II, Sec. 17	8	2½	6½	NL	NL	NL	NL	NL
<i>Special composite reinforced concrete shear walls with steel elements</i>	Ref. 8-3, Part II, Sec. 16	8	2½	6½	NL	NL	NL	NL	NL
<i>Ordinary composite reinforced concrete shear walls with steel elements</i>	Ref. 8-3, Part II, Sec. 15	7	2½	6	NL	NL	NP	NP	NP
<i>Special reinforced masonry shear walls</i>	11.11.5	7	3	6½	NL	NL	NL	NL	NL
<i>Intermediate reinforced masonry shear walls</i>	11.11.4	6½	3	5½	NL	NL	NL	NP	NP



Basic Seismic-Force-Resisting System	Detailing Reference Section	Response Modification Coefficient, $R^a$	System Over-strength Factor, $\phi^g$	Deflection Amplification Factor, $C_d^b$	System Limitations and Building Height Limitations (ft) by Seismic Design Category <sup>c</sup>				
					B	C	D <sup>d</sup>	E <sup>e</sup>	F <sup>e</sup>
<b>Dual Systems with Intermediate Moment Frames Capable of Resisting at Least 25% of Prescribed Seismic Forces</b>									
<i>Special steel concentrically braced frames<sup>f</sup></i>	Ref. 8-3, Part I, Sec. 13	6	2½	5	NL	NL	160	100	NP
<i>Ordinary steel concentrically braced frames<sup>f</sup></i>	Ref. 8-3, Part I, Sec. 14	5	2½	4½	NL	NL	160	100	NP
<i>Special reinforced concrete shear walls</i>	9.3.2.4	6	2½	5	NL	NL	160	100	100
<i>Ordinary reinforced concrete shear walls</i>	9.3.2.3	5½	2½	4½	NL	NL	NP	NP	NP
<i>Ordinary reinforced masonry shear walls</i>	11.11.3	3	3	2½	NL	160	NP	NP	NP
<i>Intermediate reinforced masonry shear walls</i>	11.11.4	5	3	4½	NL	NL	160	NP	NP
<i>Composite concentrically braced frames</i>	Ref. 8-3, Part II, Sec. 13	5	2½	4½	NL	NL	160	100	NP
<i>Ordinary composite braced frames</i>	Ref. 8-3, Part II, Sec. 12	4	2½	3	NL	NL	NP	NP	NP
<i>Ordinary composite reinforced concrete shear walls with steel elements</i>	Ref. 8-3, Part II, Sec. 15	5½	2½	4½	NL	NL	NP	NP	NP
<b>Inverted Pendulum Systems and Cantilevered Column Systems</b>									
<i>Special steel moment frames</i>	Ref. 8-3, Part I, Sec. 9	2½	2	2½	NL	NL	NL	NL	NL
<i>Ordinary steel moment frames</i>	Ref. 8-3, Part I, Sec. 11	1¼	2	2½	NL	NL	NP	NP	NP
<i>Special reinforced concrete moment frames</i>	9.3.1.3	2½	2	1¼	NL	NL	NL	NL	NL
<b>Structural Steel Systems Not Specifically Detailed for Seismic Resistance</b>	AISC-ASD, AISC-LRFD, AISI	3	3	3	NL	NL	NP	NP	NP

### NOTES FOR TABLE 5.2.2

- <sup>a</sup> Response modification coefficient,  $R$ , for use throughout the *Provisions*.
- <sup>b</sup> Deflection amplification factor,  $C_d$ , for use in Sec. 5.3.7.1 and 5.3.7.2.
- <sup>c</sup> NL = not limited and NP = not permitted. If using metric units, 100 feet approximately equals 30 m and 160 feet approximately equals 50 m. Heights are measured from the base of the structure as defined in Sec. 2.1.
- <sup>d</sup> See Sec. 5.2.2.4.1 for a description of *building* systems limited to *buildings* with a height of 240 feet (70 m) or less.
- <sup>e</sup> See Sec. 5.2.2.5 for *building* systems limited to *buildings* with a height of 160 feet (50 m) or less.
- <sup>f</sup> *Ordinary moment frame* is permitted to be used in lieu of *Intermediate moment frame* in *Seismic Design Categories* B and C.
- <sup>g</sup> The tabulated value of the *overstrength factor*,  $\phi_o$ , may be reduced by subtracting 1/2 for structures with flexible *diaphragms* but shall not be taken as less than 2.0 for any structure.
- <sup>h</sup> *Ordinary moment frames* of *reinforced concrete* are not permitted as a part of the *seismic-force-resisting system* in *Seismic Design Category B structures* founded on *Site Class E or F soils* (see Sec. 9.5.2).
- <sup>i</sup> Steel *ordinary moment frames* and *intermediate moment frames* are permitted in *single-story buildings* up to a height of 60 feet when the moment *joints* of field connections are constructed of bolted end plates and the *dead load* of the roof does not exceed 15 psf.
- <sup>j</sup> Steel *ordinary moment frames* are permitted in *buildings* up to a height of 35 feet where the *dead load* of the walls, floors, and roofs does not exceed 15 psf.

**5.2.2.4 Seismic Design Categories D and E:** The structural framing system for a *structure* assigned to *Seismic Design Categories D* and *E* shall comply with Sec. 5.2.2.3 and the additional requirements of this section.

**5.2.2.4.1 Limited Building Height:** The height limits in Table 5.2.2 is permitted to be increased to 240 ft (70 m) in *buildings* that have steel *braced frames* or concrete cast-in-place *shear walls*. Such *buildings* shall be configured such that the *braced frames* or *shear walls* arranged in any one plane conform to the following :

1. The *braced frames* or cast-in-place special reinforced concrete *shear walls* in any one plane shall resist no more than 60 percent of the total *seismic forces* in each direction, neglecting torsional effects, and
2. The seismic force in any *braced frame* or *shear wall* resulting from torsional effects shall not exceed 20 percent of the total seismic force in that *braced frame* or *shear wall*.

**5.2.2.4.2 Interaction Effects:** Moment resisting frames that are enclosed or adjoined by more rigid *elements* not considered to be part of the *seismic-force-resisting system* shall be designed so that the action or failure of those *elements* will not impair the vertical load and *seismic force* resisting capability of the frame. The design shall consider and provide for the effect of these rigid *elements* on the structural system at *structure* deformations corresponding to the design *story drift*,  $\delta$ , as determined in Sec. 5.3.7. In addition, the effects of these *elements* shall be considered when determining whether a *structure* has one or more of the irregularities defined in Sec. 5.2.3.

**5.2.2.4.3 Deformational Compatibility:** Every structural *component* not included in the *seismic-force-resisting system* in the direction under consideration shall be designed to be adequate for the vertical load-carrying capacity and the induced moments and shears resulting from the design *story drift*,  $\delta$ , as determined in accordance with Sec. 5.3.7 (also see Sec. 5.2.7).

**Exception:** Beams and columns and their connections not designed as part of the lateral-force-resisting system but meeting the detailing requirements for either *intermediate moment frames* or *special moment frames* are permitted to be designed to be adequate for the vertical load-carrying capacity and the induced moments and shears resulting from the deformation of the *building* under the application of the design *seismic forces*.

When determining the moments and shears induced in *components* that are not included in the *seismic-force-resisting system* in the direction under consideration, the stiffening effects of adjoining rigid structural and nonstructural *elements* shall be considered and a rational value of member and restraint stiffness shall be used.

**5.2.2.4.4 Special Moment Frames:** A *special moment frame* that is used but not required by Table 5.2.2 is permitted to be discontinued and supported by a more rigid system with a lower response modification coefficient,  $R$ , provided the requirements of Sec. 5.2.6.2.3 and 5.2.6.4.3 are met. Where a *special moment frame* is required by Table 5.2.2, the frame shall be continuous to the foundation.

**5.2.2.5 Seismic Design Category F:** The framing systems of *buildings* assigned to *Seismic Design Category F* shall conform to the requirements of Sec. 5.2.2.4 for *Seismic Design Categories D and E* and to the additional requirements and limitations of this section. The height limitation of Sec. 5.2.2.4.1 shall be reduced from 240 ft to 160 ft (70 to 50 m).

**5.2.3 Structure Configuration:** *Structures* shall be classified as regular or irregular based upon the criteria in this section. Such classification shall be based on the plan and vertical configuration.

**5.2.3.1 Diaphragm Flexibility:** *Diaphragms* constructed of untopped steel decking, wood structural panels, or similar panelized construction shall be considered flexible in *structures* having concrete or masonry *shear walls*. *Diaphragms* constructed of wood structural panels shall be considered rigid in light-frame *structures* using structural panels for lateral load resistance. *Diaphragms* of other types shall be considered flexible when the maximum lateral *deformation* of the *diaphragm* is more than two times the average *story drift* of the associated *story*. The loadings used for this calculation shall be those prescribed by Sec. 5.3

**5.2.3.2 Plan Irregularity:** *Structures* having one or more of the features listed in Table 5.2.3.2 shall be designated as having plan structural irregularity and shall comply with the requirements in the sections referenced in Table 5.2.3.2.

**5.2.3.3 Vertical Irregularity:** *Structures* having one or more of the features listed in Table 5.2.3.3 shall be designated as having vertical irregularity and shall comply with the requirements in the sections referenced in Table 5.2.3.3.

**Exceptions:**

1. Structural irregularities of Types 1a, 1b, or 2 in Table 5.2.3.3 do not apply where no *story drift ratio* under design lateral load is greater than 130 percent of the *story drift ratio* of the next *story* above. Torsional effects need not be considered in the calculation of *story drifts* for the purpose of this determination. The *story drift ratio* relationship for the top 2 *stories* of the *structure* are not required to be evaluated.
2. Irregularities Types 1a, 1b, and 2 of Table 5.2.3.3 are not required to be considered for 1-*story structures* or for 2-*story structures* in *Seismic Design Categories A, B, C, or D*.

TABLE 5.2.3.2 Plan Structural Irregularities

Irregularity Type and Description		Reference Section	Seismic Design Category Application
1a	<b>Torsional Irregularity--to be considered when diaphragms are not flexible</b> Torsional irregularity shall be considered to exist when the maximum <i>story</i> drift, computed including accidental torsion, at one end of the <i>structure</i> transverse to an axis is more than 1.2 times the average of the <i>story</i> drifts at the two ends of the <i>structure</i> .	5.2.6.4.3	D, E, and F
		5.3.5	C, D, E, and F
1b	<b>Extreme Torsional Irregularity -- to be considered when diaphragms are not flexible</b> Extreme torsional irregularity shall be considered to exist when the maximum <i>story</i> drift, computed including accidental torsion, at one end of the <i>structure</i> transverse to an axis is more than 1.4 times the average of the <i>story</i> drifts at the two ends of the <i>structure</i> .	5.2.6.4.3	D
		5.3.5	C and D
		5.2.6.5.1	E and F
2	<b>Re-entrant Corners</b> Plan configurations of a <i>structure</i> and its lateral force-resisting system contain re-entrant corners, where both projections of the <i>structure</i> beyond a re-entrant corner are greater than 15 percent of the plan dimension of the <i>structure</i> in the given direction.	5.2.6.4.3	D, E, and F
3	<b>Diaphragm Discontinuity</b> Diaphragms with abrupt discontinuities or variations in stiffness, including those having cutout or open areas greater than 50 percent of the gross enclosed diaphragm area, or changes in effective diaphragm stiffness of more than 50 percent from one <i>story</i> to the next.	5.2.6.4.3	D, E, and F
4	<b>Out-of-Plane Offsets</b> Discontinuities in a lateral force resistance path, such as out-of-plane offsets of the vertical <i>elements</i> .	5.2.6.4.3	D, E, and F
		5.2.6.2.10	B, C, D, E, or F
5	<b>Nonparallel Systems</b> The vertical lateral force-resisting <i>elements</i> are not parallel to or symmetric about the major orthogonal axes of the lateral force-resisting system.	5.2.6.3.1	C, D, E, and F

**TABLE 5.2.3.3 Vertical Structural Irregularities**

<b>Irregularity Type and Description</b>		<b>Reference Section</b>	<b>Seismic Design Category Application</b>
<b>1a</b>	<b>Stiffness Irregularity--Soft Story</b> A soft <i>story</i> is one in which the lateral stiffness is less than 70 percent of that in the <i>story</i> above or less than 80 percent of the average stiffness of the three stories above.	5.2.5.3	D, E, and F
<b>1b</b>	<b>Stiffness Irregularity--Extreme Soft Story</b> An extreme soft <i>story</i> is one in which the lateral stiffness is less than 60 percent of that in the <i>story</i> above or less than 70 percent of the average stiffness of the three stories above.	5.2.5.3 5.2.6.5.1	D E and F
<b>2</b>	<b>Weight (Mass) Irregularity</b> Mass irregularity shall be considered to exist where the effective mass of any <i>story</i> is more than 150 percent of the effective mass of an adjacent <i>story</i> . A roof that is lighter than the floor below need not be considered.	5.2.5.3	D, E, and F
<b>3</b>	<b>Vertical Geometric Irregularity</b> Vertical geometric irregularity shall be considered to exist where the horizontal dimension of the lateral force-resisting system in any <i>story</i> is more than 130 percent of that in an adjacent <i>story</i> .	5.2.5.3	D, E, and F
<b>4</b>	<b>In-Plane Discontinuity in Vertical Lateral Force Resisting Elements</b> An in-plane offset of the lateral force-resisting <i>elements</i> greater than the length of those <i>elements</i> or a reduction in stiffness of the resisting <i>element</i> in the <i>story</i> below.	5.2.5.3 and 5.2.6.2.10	D, E, and F
<b>5</b>	<b>Discontinuity in Capacity--Weak Story</b> A weak <i>story</i> is one in which the <i>story</i> lateral <i>strength</i> is less than 80 percent of that in the <i>story</i> above. The <i>story strength</i> is the total <i>strength</i> of all seismic-resisting <i>elements</i> sharing the <i>story</i> shear for the direction under consideration.	5.2.6.2.3 5.2.5.3 5.2.6.5.1	B, C, D, E, and F D, E, and F E and F

**5.2.4 Redundancy:** A reliability factor,  $\rho$ , shall be assigned to all *structures* in accordance with this Section, based on the extent of structural redundancy inherent in the lateral-force-resisting system.

**5.2.4.1 Seismic Design Categories A, B, and C:** For *structures* in *Seismic Design Categories A, B, and C*, the value of  $\rho$  may be taken as 1.0.

**5.2.4.2 Seismic Design Category D:** For *structures* in *Seismic Design Category D*,  $\rho$  shall be taken as the largest of the values of  $\rho_x$  calculated at each *story* of the *structure* “x” in accordance with Eq. 5.2.4-1 as follows:

$$\rho_x = 2 - \frac{20}{r_{\max_x} \sqrt{A_x}} \quad (5.2.4.2)$$

where:

$r_{\max_x}$  = the ratio of the design *story shear* resisted by the single *element* carrying the most shear force in the *story* to the total *story shear*, for a given direction of loading. For *braced frames*, the value of  $r_{\max_x}$  is equal to the lateral force *component* in the most heavily loaded brace *element* divided by the *story shear*. For *moment frames*,  $r_{\max_x}$  shall be taken as the maximum of the sum of the shears in any two adjacent columns in the plane of a *moment frame* divided by the *story shear*. For columns common to two bays with moment resisting connections on opposite sides at the level under consideration, 70 percent of the shear in that column may be used in the column shear summation. For *shear walls*,  $r_{\max_x}$  shall be taken equal to the shear in the most heavily loaded *wall* or *wall pier* multiplied by  $10/l_w$  (the metric coefficient is  $3.3/l_w$ ), where  $l_w$  is the *wall* or *wall pier* length in feet (m) divided by the *story shear*. For dual systems,  $r_{\max_x}$  shall be taken as the maximum value as defined above considering all lateral load resisting *elements* in the *story*. The lateral loads shall be distributed to *elements* based on relative rigidities considering the interaction of the dual system. For dual systems, the value of  $\rho$  need not exceed 80 percent of the value calculated above.

$A_x$  = the floor area in square feet of the *diaphragm* level immediately above the *story*.

The value of  $\rho$  need not exceed 1.5, which is permitted to be used for any *structure*. The value of  $\rho$  shall not be taken as less than 1.0.

**Exception:** For *structures* with lateral-force-resisting systems in any direction comprised solely of *special moment frames*, the lateral-force-resisting system shall be configured such that the value of  $\rho$  calculated in accordance with this section does not exceed 1.25.

The metric equivalent of Eq. 5.2.4.2 is:

$$\rho_x = 2 - \frac{6.1}{r_{\max_x} \sqrt{A_x}}$$

where  $A_x$  is in square

**5.2.4.3 Seismic Design Categories E and F:** For *structures* in *Seismic Design Categories E and F*, the value of  $\rho$  shall be calculated as indicated in Section 5.2.4.2, above.

**Exception:** For *structures* with lateral-force-resisting systems in any direction comprised solely of *special moment frames*, the lateral-force-resisting system shall be configured such that the value of  $\rho$  calculated in accordance with Sec. 5.2.4.2 does not exceed 1.1.

**5.2.5 Analysis Procedures:** A structural analysis shall be made for all *structures* in accordance with the requirements of this section. This section prescribes the minimum analysis procedure to be followed. Use of the procedure in Sec. 5.4 or, with the approval of the authority having jurisdiction, an alternate generally accepted procedure, including the use of an approved site-specific spectrum, is permitted for any *structure*. The limitations on the *base shear* stated in Sec. 5.4 apply to dynamic modal analysis.

**5.2.5.1 Seismic Design Category A:** Regular and irregular *structures* assigned to *Seismic Design Category A* shall be analyzed for minimum lateral forces given by Eq. 5.2.5.1, applied independently, in each of two orthogonal directions:

$$\text{where:} \quad F_x = 0.01 w_x \quad (5.2.5.1)$$

$F_x$  = the design lateral force applied at *Story x* and

$w_x$  = the portion of the total gravity load of the *structure*,  $W$ , located or assigned to Level  $x$  where  $W$  is as defined in Sec. 5.3.2.

**5.2.5.2 Seismic Design Categories B and C:** The analysis procedures in Sec. 5.3 shall be used for regular or irregular *structures* assigned to *Seismic Design Category B* or *C* or a more rigorous analysis is permitted to be made.

**5.2.5.3 Seismic Design Categories D, E, and F:** The analysis procedures identified in Table 5.2.5.3 shall be used for *structures* assigned to *Seismic Design Categories D, E, and F* or a more rigorous analysis is permitted to be made. For regular *structures* 5 *stories* or less in height and having a period,  $T$ , of 0.5 seconds or less, the design spectral response accelerations,  $S_{DS}$  and  $S_{DI}$ , need not exceed the values calculated in accordance with Sec. 4.1.2.5 using the values of the site adjusted *maximum considered earthquake* spectral response accelerations  $S_{MS}$  and  $S_{M1}$  given by Eq. 5.2.5.3-1 and 5.2.5.3-2, respectively:

$$S_{MS} = 1.5F_a \quad (5.2.5.3-1)$$

$$S_{M1} = 0.6F_v \quad (5.2.5.3-2)$$

where  $F_a$  and  $F_v$  are determined in accordance with Sec. 4.1.2.4 using values of  $S_a$  and  $S_v$ , respectively, of 1.5g and 0.6g. For the purpose of this section, structures are permitted to be considered regular if they do not have plan irregularities 1a, 1b, or 4 of Table 5.2.3.3 using values of  $S_a$ , 1a, 1b, 4, and 5, of Table 5.2.3.3.



**TABLE 5.2.5.3 Analysis Procedures for Seismic Design Categories D, E, and F**

Structure Description	Reference and Procedures
1. <i>Structures</i> designated as regular up to 240 feet (70 m)	Sec. 5.3
2. <i>Structures</i> that have only vertical irregularities of Type 1a, 1b, 2, or 3 in Table 5.2.3.3 or plan irregularities of Type 1a or 1b of Table 5.2.3.2 and have a height exceeding 65 feet (20 m) in height.	Sec. 5.4
3. All other <i>structures</i> designated as having plan or vertical irregularities.	Sec. 5.3 and dynamic characteristics shall be given special consideration
4. <i>Structures</i> in areas with $S_{DI}$ of 0.2 and greater with a period greater than $T_0$ located on <i>Site Class F</i> or <i>Site Class E</i> soils	A site-specific response spectrum shall be used but the design <i>base shear</i> shall not be less than that determined from Sec. 5.3.2

**5.2.5.4 Diaphragms:** The deflection in the plane of the *diaphragm* shall not exceed the permissible deflection of the attached *elements*. Permissible deflection shall be that deflection that will permit the attached *elements* to maintain structural integrity under the individual loading and continue to support the prescribed loads. Floor and roof *diaphragms* shall be designed to resist design *seismic forces* determined in accordance with Eq. 5.2.5.4 as follows:

$$F_{px} = \frac{\sum_{i=x}^n F_i}{\sum_{i=x}^n w_i} w_{px} \quad (5.2.5.4)$$

where:

- $F_{px}$  = the *diaphragm* design force,
- $F_i$  = the design force applied to Level  $i$ ,
- $w_i$  = the weight tributary to Level  $i$ , and
- $w_{px}$  = the weight tributary to the *diaphragm* at Level  $x$ .

The force determined from Eq. 5.2.5.4 need not exceed  $0.4S_{DS}Iw_{px}$  but shall not be less than  $0.2S_{DS}Iw_{px}$ . When the *diaphragm* is required to transfer design *seismic force* from the vertical resisting *elements* above the *diaphragm* to other vertical resisting *elements* below the *diaphragm* due to offsets in the placement of the *elements* or to changes in relative lateral stiffness in the vertical *elements*, these forces shall be added to those determined from Eq. 5.2.5.4.

**5.2.6 Design, Detailing Requirements, and Structural Component Load Effects:** The design and detailing of the *components* of the *seismic-force-resisting system* shall comply with the requirements of this section. Foundation design shall conform to the applicable requirements of Chapter 7. The materials and the systems composed of those materials shall conform to the requirements and limitations of Chapters 8 through 12 for the applicable category.

**5.2.6.1 Seismic Design Category A:** The design and detailing of *structures* assigned to *Seismic Design Category A* shall comply with the requirements of this section.

**5.2.6.1.1 Component Load Effects:** In addition to the evaluation required by Sec. 5.1 for other load combinations, all *structure components* shall be provided with *strengths* sufficient to resist the effects of the *seismic forces* prescribed herein and the effect of gravity loadings from *dead load*, *live load*, and snow load. The effects of the combination of loads shall be considered as prescribed in Sec. 5.2.7. The direction of application of *seismic forces* used in design shall be that which will produce the most critical load effect in each *component*. The design *seismic forces* are permitted to be applied separately in each of two orthogonal directions and orthogonal effects may be neglected.

**5.2.6.1.2 Connections:** All parts of the *structure* between separation *joints* shall be interconnected, and the connections shall be capable of transmitting the *seismic force*,  $F_p$ , induced by the parts being connected. Any smaller portion of the *structure* shall be tied to the remainder of the *structure* with *elements* having a *strength* of 0.133 times the short period design spectral response acceleration coefficient,  $S_{DS}$ , times the weight of the smaller portion or 5 percent of the portion's weight, whichever is greater.

A positive connection for resisting a horizontal force acting parallel to the member shall be provided for each beam, girder, or truss to its support. The connection shall have a minimum *strength* of 5 percent of the *dead load* and *live load* reaction.

**5.2.6.1.3 Anchorage of Concrete or Masonry Walls:** Concrete and masonry *walls* shall be anchored to the roof and all floors and members that provide lateral support for the *wall* or which are supported by the *wall*. The anchorage shall provide a direct connection between the *walls* and the roof or floor construction. The connections shall be capable of resisting a seismic lateral force,  $F_p$ , induced by the *wall* of 400 times the short period design spectral response acceleration coefficient  $S_{DS}$  in pounds per lineal foot (5840 times  $S_{DS}$  in N/m ) of *wall* multiplied by the *occupancy importance factor I*. *Walls* shall be designed to resist bending between anchors where the anchor spacing exceeds 4 ft (1.2 m).

**5.2.6.2 Seismic Design Category B:** *Structures* assigned to *Seismic Design Category B* shall conform to the requirements of Sec. 5.2.6.1 for *Seismic Design Category A* and the requirements of this section.

**5.2.6.2.1 Second-Order Effects:** In addition to meeting the requirements of Sec. 5.2.6.1.1, second-order effects shall be included where applicable.

**5.2.6.2.2 Openings:** Where openings occur in *shear walls*, *diaphragms* or other plate-type *elements*, reinforcement at the edges of the openings shall be designed to transfer the stresses into the structure. The edge reinforcement shall extend into the body of the *wall* or *diaphragm* a distance sufficient to develop the force in the reinforcement.

**5.2.6.2.3 Discontinuities in Vertical System:** Structures with a discontinuity in lateral capacity, vertical irregularity Type 5 as defined in Table 5.2.3.3, shall not be over 2 stories or 30 ft (9 m) in height where the "weak" story has a calculated *strength* of less than 65 percent of the story above.

**Exception:** Where the "weak" story is capable of resisting a total *seismic force* equal to 75 percent of the deflection amplification factor,  $C_d$ , times the design force prescribed in Sec. 5.3.

**5.2.6.2.4 Nonredundant Systems:** The design of a structure shall consider the potentially adverse effect that the failure of a single member, connection, or component of the *seismic-force-resisting system* would have on the stability of the structure.

**5.2.6.2.5 Collector Elements:** Collector elements shall be provided that are capable of transferring the *seismic forces* originating in other portions of the structure to the element providing the resistance to those forces.

**5.2.6.2.6 Diaphragms:** The deflection in the plane of the diaphragm, as determined by engineering analysis, shall not exceed the permissible deflection of the attached elements. Permissible deflection shall be that deflection which will permit the attached element to maintain its structural integrity under the individual loading and continue to support the prescribed loads.

Floor and roof diaphragms shall be designed to resist the following *seismic forces*: A minimum force equal to 20 percent of the short period design spectral response acceleration  $S_{DS}$  times the weight of the diaphragm and other elements of the structure attached thereto plus the portion of the seismic shear force at that level,  $V_x$ , required to be transferred to the components of the vertical *seismic-force-resisting system* because of offsets or changes in stiffness of the vertical components above and below the diaphragm.

Diaphragms shall provide for both the shear and bending stresses resulting from these forces. Diaphragms shall have ties or struts to distribute the wall anchorage forces into the diaphragm. Diaphragm connections shall be positive, mechanical or welded type connections.

**5.2.6.2.7 Bearing Walls:** Exterior and interior bearing walls and their anchorage shall be designed for a force equal to 40 percent of the short period design spectral response acceleration  $S_{DS}$  times the weight of wall,  $W_c$ , normal to the surface, with a minimum force of 10 percent of the weight of the wall. Interconnection of wall elements and connections to supporting framing systems shall have sufficient ductility, rotational capacity, or sufficient *strength* to resist shrinkage, thermal changes, and differential foundation settlement when combined with *seismic forces*.

**5.2.6.2.8 Inverted Pendulum-Type Structures:** Supporting columns or piers of inverted pendulum-type structures shall be designed for the bending moment calculated at the base determined using the procedures given in Sec. 5.3 and varying uniformly to a moment at the top equal to one-half the calculated bending moment at the base.

**5.2.6.2.9 Anchorage of Nonstructural Systems:** When required by Chapter 6, all portions or components of the structure shall be anchored for the *seismic force*,  $F_p$ , prescribed therein.

**5.2.6.2.10 Columns Supporting Discontinuous Walls or Frames:** Columns supporting discontinuous walls or frames of structures having plan irregularity Type 4 of Table 5.2.3.2 or vertical irregularity Type 4 of Table 5.2.3.3 shall have the *design strength* to resist the maximum axial force that can develop in accordance with the special combination of loads of Sec. 5.2.7.1.

**5.2.6.3 Seismic Design Category C:** Structures assigned to *Seismic Design Category C* shall conform to the requirements of Sec. 5.2.6.2 for *Seismic Design Category B* and to the requirements of this section.

**5.2.6.3.1 Plan Irregularity:** Structures that have plan structural irregularity Type 5 in Table 5.2.3.2 shall be analyzed for *seismic forces* applied in the direction that causes the most critical load effect. As an alternative, the *structure* may be analyzed independently in any two orthogonal directions and the most critical load effect due to direction of application of *seismic forces* on the *structure* may be assumed to be satisfied if *components* and their foundations are designed for the following combination of prescribed loads: 100 percent of the forces for one direction plus 30 percent of the forces for the perpendicular direction; the combination requiring the maximum *component strength* shall be used.

**5.2.6.3.2 Collector Elements:** *Collector elements* shall be provided that are capable of transferring the *seismic forces* originating in other portions of the *structure* to the *element* providing the resistance to those forces. *Collector elements*, splices, and their connections to resisting *elements* shall resist the load combinations of Sec. 5.2.7.1.

**Exception:** In *structures* or portions thereof braced entirely by light frame *shear walls*, *collector elements*, splices and connections to resisting *elements* need only be designed to resist forces in accordance with Eq. 5.2.5.4.

The quantity  $\phi E$  in Eq. 5.2.7.1-1 need not exceed the maximum force that can be transferred to the collector by the *diaphragm* and other *elements* of the lateral-force-resisting system.

**5.2.6.3.3 Anchorage of Concrete or Masonry Walls:** Concrete or masonry *walls* shall be anchored to all floors, roofs, and members that provide out-of-plane lateral support for the *wall* or that are supported by the *wall*. The anchorage shall provide a positive direct connection between the *wall* and floor, roof, or supporting member capable of resisting horizontal forces specified in this section for *structures* with flexible *diaphragms* or of Sec. 6.1.3 for *structures* with *diaphragms* that are not flexible.

Anchorage of *walls* to flexible *diaphragms* shall have the *strength* to develop the out-of-plane force given by Eq. 5.2.6.3.3:

$$F_p = 1.2S_{DS}IW_p \quad (5.2.6.3.3)$$

where:

- $F_p$  = the design force in the individual anchors,
- $S_{DS}$  = the design spectral response acceleration at short periods per Sec. 4.1.2.5,
- $I$  = the *occupancy importance factor* per Sec. 1.4, and
- $W_p$  = the weight of the *wall* tributary to the anchor.

*Diaphragms* shall be provided with continuous ties or struts between *diaphragm* chords to distribute these anchorage forces into the *diaphragms*. Added chords are permitted to be used to form *subdiaphragms* to transmit the anchorage forces to the main continuous cross ties. The maximum length to width ratio of the structural *subdiaphragm* shall be 2-1/2 to 1. Connections and anchorages capable of resisting the prescribed forces shall be provided between the *diaphragm* and the attached

*components*. Connections shall extend into the *diaphragm* a sufficient distance to develop the force transferred into the *diaphragm*.

In wood *diaphragms*, the continuous ties shall be in addition to the diaphragm sheathing. Anchorage shall not be accomplished by use of toe nails or nails subject to withdrawal nor shall wood ledgers of framing be used in cross-grain bending or cross-grain tension. The *diaphragm* sheathing shall not be considered effective as providing the ties or struts required by this section.

In metal deck *diaphragms*, the metal deck shall not be used as the continuous ties required by this section in the direction perpendicular to the deck span.

*Diaphragm* to wall anchorage using embedded straps shall be attached to or hooked around the reinforcing steel or otherwise terminated so as to effectively transfer forces to the reinforcing steel.

**5.2.6.4 Seismic Design Category D:** *Structures* assigned to *Seismic Design Category D* shall conform to the requirements of Sec. 5.2.6.3 for *Seismic Design Category C* and to the requirements of this section.

**5.2.6.4.1 Orthogonal Load Effects:** *Structures* shall be designed for the critical load effect due to application of *seismic forces*. The alternative procedure in Sec. 5.2.6.3.1 may be used.

**5.2.6.4.2 Collector Elements:** *Collector elements* shall be provided that are capable of transferring the *seismic forces* originating in other portions of the *structure* to the *element* providing the resistance to those forces. *Collector elements*, splices, and their connections to resisting *elements* shall resist the forces determined in accordance with Eq. 5.2.4.5. In addition, *collector elements*, splices and their connections to resisting *elements* shall have the *design strength* to resist the earthquake loads as defined in the special load combination of Sec. 5.2.7.1.

**Exception:** In *structures* or portions thereof braced entirely by light *shear walls*, *collector elements*, splices, and connections to resisting *elements* need only be designed to resist forces in accordance with Eq. 5.2.5.4.

The quantity  $\phi E$  in Eq. 5.2.7.1-1 need not exceed the maximum force that can be transferred to the collector by the *diaphragm* and other *elements* of the lateral-force-resisting system.

**5.2.6.4.3 Plan or Vertical Irregularities:** The design shall consider the potential for adverse effects when the ratio of the *strength* provided in any *story* to the *strength* required is significantly less than that ratio for the *story* immediately above and the *strengths* shall be adjusted to compensate for this effect.

For *structures* having a plan structural irregularity of Type 1a, 1b, 2, 3, or 4 in Table 5.2.3.2 or a vertical structural irregularity of Type 4 in Table 5.2.3.3, the design forces determined from Sec. 5.3.2 shall be increased 25 percent for connections of *diaphragms* to vertical *elements* and to collectors and for connections of collectors to the vertical *elements*.

**5.2.6.4.4 Vertical Seismic Forces:** The vertical *component* of earthquake ground motion shall be considered in the design of horizontal cantilever and horizontal prestressed *components*. The load combinations used in evaluating such *components* shall include *E* as defined by Eq. 5.2.7-1 and 5.2.7-1. Horizontal cantilever structural *components* shall be designed for a minimum net upward force of 0.2 times the *dead load* in addition to the applicable load combinations of Sec. 5.2.7.

**5.2.6.5 Seismic Design Categories E and F:** Structures assigned to *Seismic Design Categories E* and *F* shall conform to the requirements of Sec. 5.2.6.4 for *Seismic Design Category D* and to the requirements of this section.

**5.2.6.5.1 Plan or Vertical Irregularities:** Structures having plan irregularity Type 1b of Table 5.2.3.2 or vertical irregularities Type 1b or 5 of Table 5.2.3.3 shall not be permitted.

**5.2.7 Combination of Load Effects:** The effects on the *structure* and its *components* due to *gravity loads* and *seismic forces* shall be combined in accordance with the factored load combinations as presented in ASCE 7 (Ref. 5-1) except that the effect of seismic loads,  $E$ , shall be as defined herein.

The effect of seismic load  $E$  shall be defined by Eq. 5.2.7-1 as follows for load combinations in which the effects of *gravity loads* and seismic loads are additive:

$$\text{where:} \quad E = \rho Q_E + 0.2 S_{DS} D \quad (5.2.7-1)$$

- $E$  = the effect of horizontal and vertical earthquake-induced forces,
- $S_{DS}$  = the design spectral response acceleration at short periods obtained from Sec. 4.1.2.5.
- $D$  = the effect of dead load,
- $\rho$  = the reliability factor, and
- $Q_E$  = the effect of horizontal *seismic forces*.

The effect of seismic load  $E$  shall be defined by Eq. 5.2.7-2 as follows for load combinations in which the effects of gravity counteract seismic load:

$$E = \rho Q_E - 0.2 S_{DS} D \quad (5.2.7-2)$$

where  $E$ ,  $Q_E$ ,  $S_{DS}$ , and  $D$  are as defined above.

**5.2.7.1 Special Combination of Loads:** When specifically required by these *Provisions*, the design *seismic force* on *components* sensitive to the effects of structural overstrength shall be as defined by Eq. 5.2.7.1-1 and 5.2.7.1-2 when seismic load is respectively additive or counteractive to the gravity forces as follows:

$$E = \Omega_0 Q_E + 0.2 S_{DS} D \quad (5.2.7.1-1)$$

where  $E$ ,  $Q_E$ ,  $S_{DS}$ , and  $D$  are as defined above and  $\Omega_0$  is the system overstrength factor.  $E = \Omega_0 Q_E - 0.2 S_{DS} D$  (5.2.7.1-2)

5.2.2. The term  $Q_E$  calculated in accordance with Eq. 5.2.7.1-1 and 5.2.7.1-2 shall not exceed the maximum force that can develop in the *element* as determined by a rational plastic mechanism analysis or nonlinear response analysis utilizing realistic expected values of material *strengths*.

---

**Exception:** The special load combination of Eq. 5.2.7.1-1 need not apply to the design of *components in structures* in *Seismic Design Category A*.

**5.2.8 Deflection and Drift Limits:** The design *story* drift,  $\delta$ , as determined in Sec. 5.3.7 or 5.4.6, shall not exceed the allowable *story* drift,  $\delta_a$ , as obtained from Table 5.2.8 for any *story*. For *structures* with significant torsional deflections, the maximum drift shall include torsional effects. All portions of the *structure* shall be designed and constructed to act as an integral unit in resisting *seismic forces* unless separated structurally by a distance sufficient to avoid damaging contact under total deflection,  $\delta_x$ , as determined in Sec. 5.3.7.1.

**TABLE 5.2.8 Allowable Story Drift,  $\Delta_a^a$  (in. or mm)**

Structure	Seismic Use Group		
	I	II	III
Structures, other than masonry <i>shear wall</i> or masonry <i>wall frame structures</i> , four stories or less in height with interior <i>walls, partitions</i> , ceilings, and exterior <i>wall</i> systems that have been designed to accommodate the <i>story drifts</i>	$0.025 h_{sx}^b$	$0.020 h_{sx}$	$0.015 h_{sx}$
Masonry cantilever <i>shear wall structures</i> <sup>c</sup>	$0.010 h_{sx}$	$0.010 h_{sx}$	$0.010 h_{sx}$
Other masonry <i>shear wall structures</i>	$0.007 h_{sx}$	$0.007 h_{sx}$	$0.007 h_{sx}$
Masonry <i>wall frame structures</i>	$0.013 h_{sx}$	$0.013 h_{sx}$	$0.010 h_{sx}$
All other <i>structures</i>	$0.020 h_{sx}$	$0.015 h_{sx}$	$0.010 h_{sx}$

<sup>a</sup>  $h_{sx}$  is the *story height* below Level  $x$ .

<sup>b</sup> There shall be no drift limit for single-story structures with interior *walls, partitions*, ceilings, and exterior *wall* systems that have been designed to accommodate the *story drifts*.

<sup>c</sup> Structures in which the basic structural system consists of masonry *shear walls* designed as vertical *elements* cantilevered from their *base* or foundation support which are so constructed that moment transfer between *shear walls* (coupling) is negligible.

### 5.3 EQUIVALENT LATERAL FORCE PROCEDURE:

**5.3.1 General:** This section provides required minimum standards for the equivalent lateral force procedure of seismic analysis of *structures*. For purposes of analysis, the *structure* is considered to be fixed at the *base*. See Sec. 5.2.4 for limitations on the use of this procedure.

**5.3.2 Seismic Base Shear:** The seismic *base shear*,  $V$ , in a given direction shall be determined in accordance with the following equation:

$$V = C_s W \quad (5.3.2)$$

where:

$C_s$  = the *seismic response coefficient* determined in accordance with Sec. 5.3.2.1 and

$W$  = the total *dead load* and applicable portions of other loads\* listed below:

1. In areas used for storage, a minimum of 25 percent of the floor *live load* shall be applicable. Floor *live load* in public garages and open parking *structures* is not applicable.

---

\*The *live load* may be reduced for tributary area as permitted by the structural code administered by the authority having jurisdiction.



2. Where an allowance for *partition* load is included in the floor load design, the actual *partition* weight or a minimum weight of 10 psf (500 Pa/m<sup>2</sup>) of floor area, whichever is greater, shall be applicable.
3. Total operating weight of permanent equipment.
4. In areas where the design flat roof snow load does not exceed 30 pounds per square foot, the effective snow load is permitted to be taken as zero. In areas where the design snow load is greater than 30 pounds per square foot and where siting and load duration conditions warrant and when approved by the authority having jurisdiction, the effective snow load is permitted to be reduced to not less than 20 percent of the design snow load.

**5.3.2.1 Calculation of Seismic Response Coefficient:** The *seismic response coefficient*,  $C_s$ , shall be determined in accordance with the following equation:

$$C_s = \frac{S_{DS}}{R/I} \quad (5.3.2.1-1)$$

where:

$S_{DS}$  = the design spectral response acceleration in the short period range as determined from Sec. 4.1.2.5,

$R$  = the response modification factor from Table 5.2.2, and

$I$  = the *occupancy importance factor* determined in accordance with Sec. 1.4.

The value of the *seismic response coefficient* computed in accordance with Eq. 5.3.2.1-1 need not exceed the following:

$$C_s = \frac{S_{DI}}{T(R/I)} \quad (5.3.2.1-2)$$

but shall not be taken less than:

$$C_s = 0.1 S_{DI} I \quad (5.3.2.1-3)$$

nor for *buildings* and *structures* in *Seismic Design Categories* E and F:

$$C_s = \frac{0.5 S_1}{R/I} \quad (5.3.2.1-4)$$

where  $I$  and  $R$  as as defined above and

$S_{DI}$  = the design spectral response acceleration at a period of 1.0 second as determined from Sec. 4.1.2.5,

$T$  = the fundamental period of the *structure* (sec) determined in Sec. 5.3.3, and

$S_I$  = the mapped *maximum considered earthquake* spectral response acceleration determined in accordance with Sec. 4.1.

A soil-*structure* interaction reduction is permitted when determined using Sec. 5.5 or other generally accepted procedures approved by the authority having jurisdiction.

**5.3.3 Period Determination:** The fundamental period of the *building*,  $T$ , in the direction under consideration shall be established using the structural properties and deformational characteristics of the resisting *elements* in a properly substantiated analysis or, alternatively, it is permitted to be taken as the approximate fundamental period,  $T_a$ , determined in accordance with the requirements of Sec. 5.3.3.1. The fundamental period,  $T$ , shall not exceed the product of the coefficient for upper limit on calculated period,  $C_u$ , from Table 5.3.3 and the approximate fundamental period,  $T_a$ .

**TABLE 5.3.3 Coefficient for Upper Limit on Calculated Period**

Design Spectral Response Acceleration at 1 Second, $S_{DI}$	Coefficient $C_u$
$\geq 0.4$	1.2
0.3	1.3
0.2	1.4
0.15	1.5
0.1	1.7
0.05	1.7

**5.3.3.1 Approximate Fundamental Period:** The approximate fundamental period,  $T_a$ , in seconds, shall be determined from the following equation:

where:

$$T_a = C_T h_n^{3/4} \quad (5.3.3.1-1)$$

$C_T = 0.035$  for moment resisting frame systems of steel in which the frames resist 100 percent of the required *seismic force* and are not enclosed or adjoined by more rigid *components* that will prevent the frames from deflecting when subjected to *seismic forces* (the metric coefficient is 0.0853),

$C_T = 0.030$  for moment resisting frame systems of *reinforced concrete* in which the frames resist 100 percent of the required *seismic force* and are not enclosed or adjoined by more rigid *components* that will prevent the frames from deflecting when subjected to *seismic forces* (the metric coefficient is 0.0731),

$C_T = 0.030$  for eccentrically braced steel frames (the metric coefficient is 0.0731),

$C_T = 0.020$  for all other structural systems (the metric coefficient is 0.0488), and

$h_n =$  the height (ft or m) above the *base* to the highest level of the *structure*.

Alternatively, the approximate fundamental period,  $T_a$ , in seconds, is permitted to be determined from the following equation for concrete and steel moment resisting frame *structures* not exceeding 12 *stories* in height and having a minimum *story* height of 10 ft (3 m):

$$\text{where } N = \text{number of stories. } T_a = 0.1N \quad (5.3.3.1-2)$$

**5.3.4 Vertical Distribution of Seismic Forces:** The lateral force,  $F_x$  (kip or kN), induced at any level shall be determined from the following equations:

$$F_x = C_{vx} V \quad (5.3.4-1)$$

and

$$C_{vx} = \frac{W_x h_x^k}{\sum_{i=1}^n w_i h_i^k} \quad (5.3.4-2)$$

where:

$C_{vx}$  = vertical distribution factor,

$V$  = total design lateral force or shear at the *base* of the *structure* (kip or kN),

$w_i$  and  $w_x$  = the portion of the total *gravity load* of the *structure*,  $W$ , located or assigned to Level  $i$  or  $x$ ,

$h_i$  and  $h_x$  = the height (ft or m) from the *base* to Level  $i$  or  $x$ , and

$k$  = an exponent related to the *structure* period as follows:

For *structures* having a period of 0.5 seconds or less,  $k = 1$

For *structures* having a period of 2.5 seconds or more,  $k = 2$

For *structures* having a period between 0.5 and 2.5 seconds,  $k$  shall be 2 or shall be determined by linear interpolation between 1 and 2

**5.3.5 Horizontal Shear Distribution:** The seismic design *story shear* in any *story*,  $V_x$  (kip or kN), shall be determined from the following equation:

$$V_x = \sum_{i=x}^n F_i \quad (5.3.5)$$

where  $F_i$  = the portion of the seismic *base shear*

at,  $V$  (kip or kN), induced at Level  $I$ .

The seismic design *story shear*,  $V_x$  (kip or kN), shall be distributed to the various vertical *elements* of the *seismic-force-resisting system* in the *story* under consideration based on the relative lateral stiffnesses of the vertical resisting *elements* and the *diaphragm*.

**5.3.5.1 Torsion:** The design shall include the torsional moment,  $M_t$  (kip·ft or kN·m), resulting from the location of the masses.

**5.3.5.2 Accidental Torsion:** In addition to the torsional moment, the design also shall include accidental torsional moments,  $M_{ta}$  (kip·ft or kN·m), caused by an assumed *displacement* of the mass each way from its actual location by a distance equal to 5 percent of the dimension of the *structure* perpendicular to the direction of the applied forces.

**5.3.5.3 Dynamic Amplification of Torsion:** For *structures* of *Seismic Design Categories* C, D, E, and F, where Type 1 torsional irregularity exists as defined in Table 5.2.3.1, the effects of torsional irregularity shall be accounted for by multiplying the sum of  $M_t$  plus  $M_{ta}$  at each level by a torsional amplification factor,  $A_x$ , determined from the following equation:

$$A_x = \left( \frac{\frac{max}{1.2}}{avg} \right)^2 \quad (5.3.5.3)$$

where:

- $max$  = the maximum *displacement* at Level  $x$  (in. or mm) and
- $avg$  = the average of the *displacements* at the extreme points of the *structure* at Level  $x$  (in. or mm).

The torsional amplification factor,  $A_x$ , is not required to exceed 3.0. The more severe loading for each *element* shall be considered for design.

**5.3.6 Overturning:** The *structure* shall be designed to resist overturning effects caused by the *seismic forces* determined in Sec. 5.3.4. At any *story*, the increment of overturning moment in the *story* under consideration shall be distributed to the various vertical force resisting *elements* in the same proportion as the distribution of the horizontal shears to those *elements*.

The overturning moments at Level  $x$ ,  $M_x$  (kip·ft or kN·m), shall be determined from the following equation:

$$M_x = \sum_{i=x}^n F_i (h_i = h_x) \quad (5.3.6)$$

where:

- $F_i$  = the portion of the seismic *base shear*,  $V$ , induced at Level  $i$ ,
- $h_i$  and  $h_x$  = the height (ft or m) from the *base* to Level  $i$  or  $x$ ,
- = 1.0 for the top 10 stories,
- = 0.8 for the 20th *story* from the top and below, and

= a value between 1.0 and 0.8 determined by a straight line interpolation for *stories* between the 20th and 10th *stories* below the top.

The foundations of *structures*, except *inverted pendulum-type structures*, shall be designed for the foundation overturning design moment,  $M_f$  (kip·ft or kN·m), at the foundation-soil interface determined using the equation for the overturning moment at Level  $x$ ,  $M_x$  (kip·ft or kN·m), with an overturning moment reduction factor,  $\gamma$ , of 0.75 for all *structure* heights.

**5.3.7 Drift Determination and P-Delta Effects:** *Story* drifts and, where required, member forces and moments due to *P-delta effects* shall be determined in accordance with this section.

Determination of *story* drifts shall be based on the application of the design *seismic forces* to a mathematical model of the physical *structure*. The model shall include the stiffness and *strength* of all *elements* that are significant to the distribution of forces and *deformations* in the *structure* and shall represent the spatial distribution of the mass and stiffness of the *structure*. In addition, the model shall comply with the following:

1. Stiffness properties of *reinforced concrete* and masonry *elements* shall consider the effects of cracked sections and
2. For steel *moment resisting frame* systems, the contribution of panel zone *deformations* to overall *story* drift shall be included.

**5.3.7.1 Story Drift Determination:** The design *story* drift,  $\Delta$ , shall be computed as the difference of the deflections at the center of mass at the top and bottom of the *story* under consideration.

**Exception:** For *structures* of *Seismic Design Categories* C, D, E and F having plan irregularity Types 1a or 1b of Table 5.3.2.1, the design *story* drift,  $\Delta$ , shall be computed as the largest difference of the deflections along any of the edges of the *structure* at the top and bottom of the *story* under consideration.

The deflections of Level  $x$ ,  $\delta_x$  (in. or mm), shall be determined in accordance with following equation:

$$\delta_x = \frac{C_d \delta_{xe}}{I} \quad (5.3.7.1)$$

where:

- $C_d$  = the deflection amplification factor in Table 5.2.2,
- $\delta_{xe}$  = the deflections determined by an elastic analysis (in. or mm), and
- $I$  = the *occupancy importance factor* determined in accordance with Sec. 1.4.

The elastic analysis of the *seismic-force-resisting system* shall be made using the prescribed seismic design forces of Sec. 5.3.4.

For determining compliance with the *story* drift limitation of Sec. 5.2.8, the deflections of Level  $x$ ,  $\delta_x$  (in. or mm), shall be calculated as required in this section. For purposes of this drift analysis only, it is permissible to use the computed fundamental period,  $T$ , in seconds, of the *structure* without the upper bound limitation specified in Sec. 5.3.3 when determining drift level seismic design forces.

Where applicable, the design *story drift*,  $\Delta$  (in. or mm), shall be increased by the incremental factor relating to the *P-delta effects* as determined in Sec. 5.3.7.2.

**5.3.7.2 P-Delta Effects:** *P-delta effects* on *story shears* and moments, the resulting member forces and moments, and the *story drifts* induced by these effects are not required to be considered when the stability coefficient,  $\lambda$ , as determined by the following equation is equal to or less than 0.10:

$$\lambda = \frac{P_x \Delta}{V_x h_{sx} C_d} \quad (5.3.7.2-1)$$

where:

- $P_x$  = the total vertical design load at and above Level  $x$  (kip or kN); when calculating the vertical design load for purposes of determining *P-delta*, the individual load factors need not exceed 1.0;
- $\Delta$  = the design *story drift* occurring simultaneously with  $V_x$  (in. or mm);
- $V_x$  = the seismic shear force acting between Level  $x$  and  $x - 1$  (kip or kN);
- $h_{sx}$  = the *story height* below Level  $x$  (in. or mm); and
- $C_d$  = the deflection amplification factor in Table 5.2.2.

The stability coefficient,  $\lambda$ , shall not exceed  $\lambda_{max}$  determined as follows:

$$\lambda_{max} = \frac{0.5}{C_d} \leq 0.25 \quad (5.3.7.2-2)$$

where  $\lambda$  is the ratio of shear demand to shear capacity for the *story* between Level  $x$  and  $x - 1$ . This ratio is permitted to be conservatively taken as 1.0.

When the stability coefficient,  $\lambda$ , is greater than 0.10 but less than or equal to  $\lambda_{max}$ , the incremental factor related to *P-delta effects*,  $a_p$ , shall be determined by rational analysis (see Part 2, *Commentary*). To obtain the *story drift* for including the *P-delta effects*, the design *story drift* determined in Sec. 5.3.7.1 shall be multiplied by  $1.0/(1 - a_p)$ .

When  $\lambda$  is greater than  $\lambda_{max}$ , the *structure* is potentially unstable and shall be redesigned.

## 5.4 MODAL ANALYSIS PROCEDURE:

**5.4.1 General:** This chapter provides required standards for the modal analysis procedure of seismic analysis of *structures*. See Sec. 5.2.5 for requirements for use of this procedure. The symbols used in this method of analysis have the same meaning as those for similar terms used in Sec. 5.3, with the subscript  $m$  denoting quantities in the  $m^{\text{th}}$  mode.

**5.4.2 Modeling:** A mathematical model of the *structure* shall be constructed that represents the spatial distribution of mass and stiffness throughout the *structure*. For regular *structures* with independent orthogonal *seismic-force-resisting systems*, independent two-dimensional models are permitted to be constructed to represent each system. For irregular *structures* or *structures* without independent orthogonal systems, a three-dimensional model incorporating a minimum of three dynamic degrees of freedom consisting of translation in two orthogonal plan directions and torsional

rotation about the vertical axis shall be included at each level of the *structure*. Where the *diaphragms* are not rigid compared to the vertical *elements* of the lateral-force-resisting system, the model should include representation of the diaphragm's flexibility and such additional dynamic degrees of freedom as are required to account for the participation of the *diaphragm* in the *structure's* dynamic response. In addition, the model shall comply with the following:

1. Stiffness properties of concrete and masonry *elements* shall consider the effects of cracked sections and
2. For steel *moment frame* systems, the contribution of panel zone *deformations* to overall *story* drift shall be included.

**5.4.3 Modes:** An analysis shall be conducted to determine the natural modes of vibration for the *structure* including the period of each mode, the modal shape vector  $\phi$ , the modal participation factor, and modal mass. The analysis shall include a sufficient number of modes to obtain a combined modal mass participation of at least 90 percent of the actual mass in each of two orthogonal directions.

**5.4.4 Modal Properties:** The required periods, mode shapes, and participation factors of the *structure* shall be calculated by established methods of structural analysis for the fixed-*base* condition using the masses and elastic stiffnesses of the *seismic-force-resisting system*.

**5.4.5 Modal Base Shear:** The portion of the *base shear* contributed by the  $m^{\text{th}}$  mode,  $V_m$ , shall be determined from the following equations:

$$V_m = C_{sm} \overline{W}_m \quad (5.4.5-1)$$

$$\overline{W}_m = \frac{\left( \sum_{i=1}^n w_i \phi_{im} \right)^2}{\sum_{i=1}^n w_i \phi_{im}^2} \quad (5.4.5-2)$$

where:

- $C_{sm}$  = the modal *seismic response coefficient* determined below,
- $\overline{W}_m$  = the effective modal *gravity load* including portions of the *live load* as defined in Sec. 5.3.2,
- $w_i$  = the portion of the total *gravity load* of the *structure* at Level  $i$ , and
- $\phi_{im}$  = the *displacement* amplitude at the  $i^{\text{th}}$  level of the *structure* when vibrating in its  $m^{\text{th}}$  mode.

The modal *seismic response coefficient*,  $C_{sm}$ , shall be determined in accordance with the following equation:

$$C_{sm} = \frac{S_{am}}{R/I} \quad (5.4.5-3)$$

- $S_{am}$  = The design spectral response acceleration at period  $T_m$  determined from either the general design response spectrum of Sec. 4.1.2.5 or a site-specific response spectrum per Sec. 4.1.3,
- $R$  = the response modification factor determined from Table 5.2.2,
- $I$  = the *occupancy importance factor* determined in accordance with Sec. 1.4, and
- $T_m$  = the modal period of vibration (in seconds) of the  $m^{\text{th}}$  mode of the *structure*.

**Exceptions:**

1. When the general design response spectrum of Sec. 4.1.2.6 is used for *structures* on *Site Class* D, E, or F soils, the modal seismic design coefficient,  $C_{sm}$ , for modes other than the fundamental mode that have periods less than 0.3 seconds is permitted to be determined by the following equation:

$$C_{sm} = \frac{0.4S_{DS}}{(R/I)}(1.0 + 5.0T_m) \quad (5.4.5-4)$$

where  $S_{DS}$  is as defined in Sec. 4.1.2.5 and  $R$ ,  $I$ , and  $T_m$  are as defined above.

2. When the general design response spectrum of Sec. 4.1.2.6 is used for *structures* where any modal period of vibration,  $T_m$ , exceeds 4.0 seconds, the modal seismic design coefficient,  $C_{sm}$ , for that mode is permitted to be determined by the following equation:

$$C_{sm} = \frac{4S_{D1}}{(R/I)T_m^2} \quad (5.4.5-5)$$

where  $R$ ,  $I$ , and  $T_m$  are as defined above and  $S_{D1}$  is the design spectral response acceleration at a period of 1 second as determined in Sec. 4.1.2.5.

The reduction due to soil-*structure* interaction as determined in Sec. 5.5.3 may be used.

**5.4.6 Modal Forces, Deflections, and Drifts:** The modal force,  $F_{xm}$ , at each level shall be determined by the following equations:

$$F_{xm} = C_{vsm} V_m \quad (5.4.6-1)$$

and

$$C_{vsm} = \frac{w_x \phi_{xm}}{\sum_{i=1}^n w_i \phi_{im}} \quad (5.4.6-2)$$

where:

- $C_{vsm}$  = the vertical distribution factor in the  $m^{\text{th}}$  mode,
- $V_m$  = the total design lateral force or shear at the *base* in the  $m^{\text{th}}$  mode,



- $w_i, w_x$  = the portion of the total *gravity load*,  $W$ , located or assigned to Level  $i$  or  $x$ ,
- $\phi_{xm}$  = the *displacement* amplitude at the  $x^{\text{th}}$  level of the *structure* when vibrating in its  $m^{\text{th}}$  mode, and
- $\phi_{im}$  = the *displacement* amplitude at the  $i^{\text{th}}$  level of the *structure* when vibrating in its  $m^{\text{th}}$  mode.

The modal deflection at each level,  $\delta_{xm}$ , shall be determined by the following equations:

$$\delta_{xm} = \frac{C_d \cdot \delta_{xem}}{I} \quad (5.4.6-3)$$

and

$$\delta_{xem} = \left( \frac{g}{4} \right)^2 \left( \frac{T_m^2 F_{xm}}{W_x} \right) \quad (5.4.6-4)$$

where:

- $C_d$  = the deflection amplification factor determined from Table 5.2.2,
- $\delta_{xem}$  = the deflection of Level  $x$  in the  $m^{\text{th}}$  mode at the center of the mass at Level  $x$  determined by an elastic analysis,
- $g$  = the acceleration due to gravity (ft/s<sup>2</sup> or m/s<sup>2</sup>),
- $I$  = the *occupancy importance factor* determined in accordance with Sec. 1.4,
- $T_m$  = the modal period of vibration, in seconds, of the  $m^{\text{th}}$  mode of the *structure*,
- $F_{xm}$  = the portion of the seismic *base shear* in the  $m^{\text{th}}$  mode, induced at Level  $x$ , and
- $W_x$  = the portion of the total *gravity load* of the *structure*,  $W$ , located or assigned to Level  $x$ .

The modal drift in a *story*,  $\delta_m$ , shall be computed as the difference of the deflections,  $\delta_{xm}$ , at the top and bottom of the *story* under consideration.

**5.4.7 Modal Story Shears and Moments:** The *story shears*, *story* overturning moments, and the shear forces and overturning moments in vertical *elements* of the structural system at each level due to the *seismic forces* determined from the appropriate equation in Sec. 5.4.6 shall be computed for each mode by linear static methods.

**5.4.8 Design Values:** The design value for the modal *base shear*,  $V_i$ ; each of the *story shear*, moment and drift quantities; and the deflection at each level shall be determined by combining their modal values as obtained from Sec. 5.4.6 and 5.4.7. The combination shall be carried out by taking the square root of the sum of the squares of each of the modal values or by the complete quadratic combination technique.

The *base shear*,  $V$ , using the equivalent lateral force procedure in Sec. 5.3 shall be calculated using a fundamental period of the *structure*,  $T$ , in seconds, of 1.2 times the coefficient for upper limit on the calculated period,  $C_u$ , times the approximate fundamental period of the *structure*,  $T_a$ . Where the design value for the modal *base shear*,  $V_p$ , is less than the calculated *base shear*,  $V$ , using the equivalent lateral force procedure, the design *story shears*, moments, drifts and floor deflections shall be multiplied by the following modification factor:

$$\frac{V}{V_t} \quad (5.4.8)$$

where:

$V$  = the equivalent lateral force procedure *base shear*, calculated in accordance with this section and Sec. 5.3 and

$V_t$  = the modal *base shear*, calculated in accordance with this section.

The modal *base shear*,  $V_t$ , is not required to exceed the *base shear* from the equivalent lateral force procedure in Sec. 5.3.

**Exception:** For *structures* with a period of 0.7 second or greater located on *Site Class* E or F soils and having an  $S_{DI}$  greater than 0.2, the design *base shear* shall not be less than that determined using the equivalent lateral force procedure in Sec. 5.3 (see Sec. 5.2.5.3).

**5.4.9 Horizontal Shear Distribution:** The distribution of horizontal shear shall be in accordance with the requirements of Sec. 5.3.5 except that amplification of torsion per Sec. 5.3.5.3 is not required for that portion of the torsion included in the dynamic analysis model.

**5.4.10 Foundation Overturning:** The foundation overturning moment at the foundation-soil interface shall be permitted to be reduced by 10 percent.

**5.4.11 P-Delta Effects:** The *P-delta effects* shall be determined in accordance with Sec. 5.3.7.2. The *story drifts* and *story shears* shall be determined in accordance with Sec. 5.3.7.1.

## 5.5 SOIL-STRUCTURE INTERACTION EFFECTS:

**5.5.1 General:** The requirements set forth in this section are permitted to be used to incorporate the effects of soil-*structure* interaction in the determination of the *design earthquake* forces and the corresponding *displacements* of the *structure*. The use of these requirements will decrease the design values of the *base shear*, lateral forces, and overturning moments but may increase the computed values of the lateral *displacements* and the secondary forces associated with the *P-delta* effects.

The requirements for use with the equivalent lateral force procedure are given in Sec. 5.5.2 and those for use with the modal analysis procedure are given in Sec. 5.5.3.

**5.5.2 Equivalent Lateral Force Procedure:** The following requirements are supplementary to those presented in Sec. 5.3.

**5.5.2.1 Base Shear:** To account for the effects of soil-*structure* interaction, the *base shear*,  $V$ , determined from Eq. 5.3.2-1 may be reduced to:

$$\tilde{V} = V - \Delta V \quad (5.5.2.1-1)$$

The reduction,  $\Delta V$ , shall be computed as follows:

$$\Delta V = \left[ C_s - \tilde{C}_s \left( \frac{0.05}{\tilde{}} \right)^{0.4} \right] \overline{W} \quad (5.5.2.1-2)$$

where:

- $C_s$  = the *seismic response coefficient* computed from Eq. 5.3.2.1-1 using the fundamental natural period of the fixed-base *structure* ( $T$  or  $T_n$ ) as specified in Sec. 5.3.3,
- $C_s^f$  = the *seismic response coefficient* computed from Eq. 5.3.2.1-1 using the fundamental natural period of the flexibly supported *structure* ( $T$ ) defined in Sec. 5.5.2.1.1,
- $\tilde{\gamma}$  = the fraction of critical damping for the *structure*-foundation system determined in Sec. 5.5.2.1.2, and
- $W$  = the effective *gravity load* of the *structure*, which shall be taken as  $0.7W$ , except that for *structures* where the *gravity load* is concentrated at a single level, it shall be taken equal to  $W$ .

The reduced *base shear*,  $\tilde{V}$ , shall in no case be taken less than  $0.7V$ .

**5.5.2.1.1 Effective Building Period:** The effective period,  $T$ , shall be determined as follows:

$$\tilde{T} = T \sqrt{1 + \frac{\bar{k}}{K_y} \left( 1 + \frac{K_y \bar{h}^2}{K} \right)} \quad (5.5.2.1.1-1)$$

where:

- $T$  = the fundamental period of the *structure* as determined in Sec. 5.3.3;
- $\bar{k}$  = the stiffness of the *structure* when fixed at the *base*, defined by the following:

$$\bar{k} = 4 \left( \frac{\bar{W}}{gT^2} \right) \quad (5.5.2.1.1-2)$$

- $\bar{h}$  = the effective height of the *structure* which shall be taken as 0.7 times the total height,  $h_n$ , except that for *structures* where the *gravity load* is effectively concentrated at a single level, it shall be taken as the height to that level;
- $K_y$  = the lateral stiffness of the foundation defined as the static horizontal force at the level of the foundation necessary to produce a unit deflection at that level, the force and the deflection being measured in the direction in which the *structure* is analyzed;
- $K$  = the rocking stiffness of the foundation defined as the static moment necessary to produce a unit average rotation of the foundation, the moment and rotation being measured in the direction in which the *structure* is analyzed; and
- $g$  = the acceleration of gravity.

The foundation stiffnesses,  $K_y$  and  $K$ , shall be computed by established principles of foundation mechanics (see the *Commentary*) using soil properties that are compatible with the soil strain levels associated with the design earthquake motion. The average shear modulus,  $G$ , for the soils beneath the foundation at large strain levels and the associated shear wave velocity,  $v_s$ , needed in these computations shall be determined from Table 5.5.2.1.1 where:

- $v_{so}$  = the average shear wave velocity for the soils beneath the foundation at small strain levels ( $10^{-3}$  percent or less),
- $G_o$  =  $v_{so}^2/g$  = the average shear modulus for the soils beneath the foundation at small strain levels, and
- = the average unit weight of the soils.

**TABLE 5.5.2.1.1 Values of  $G/G_o$  and  $v_s/v_{so}$** 

	Spectral Response Acceleration, $S_{DI}$			
	$\leq 0.10$	$\leq 0.15$	<b>0.20</b>	$\geq 0.30$
Value of $G/G_o$	0.81	0.64	0.49	0.42
Value of $V_s/v_{so}$	0.90	0.80	0.70	0.65

Alternatively, for *structures* supported on mat foundations that rest at or near the ground surface or are embedded in such a way that the side *wall* contact with the soil cannot be considered to remain effective during the design ground motion, the effective period of the *structure* is permitted to be determined as follows:

$$\tilde{T} = T \sqrt{1 + \frac{25 r_a \bar{h}}{v_s^2 T^2} \left( 1 + \frac{1.12 r_a \bar{h}^2}{r_m^3} \right)} \quad (5.5.2.1.1-3)$$

where:

- = the relative weight density of the *structure* and the soil defined by:

$$= \frac{\bar{W}}{A_o \bar{h}} \quad (5.5.2.1.1-4)$$

- $r_a$  and  $r_m$  = characteristic foundation lengths defined by:

$$R_a = \sqrt{\frac{A_o}{-}} \quad (5.5.2.1.1-5)$$

and

$$r_m = \sqrt[4]{\frac{4I_o}{-}} \quad (5.5.2.1.1-6)$$

where:

$A_o$  = the area of the foundation and

$I_o$  = the static moment of the foundation about a horizontal centroidal axis normal to the direction in which the *structure* is analyzed.

**5.5.2.1.2 Effective Damping:** The *effective damping* factor for the *structure*-foundation system,  $\tilde{\gamma}$ , shall be computed as follows:

$$\tilde{\gamma} = \gamma_o + \frac{0.05}{\left(\frac{\tilde{T}}{T}\right)^3} \quad (5.5.2.1.2-1)$$

where  $\gamma_o$  = the foundation damping factor as specified in Figure 5.5.2.1.2.

The values of  $\gamma_o$  corresponding to  $A_v = 0.15$  in Figure 5.5.2.1.2 shall be determined by averaging the results obtained from the solid lines and the dashed lines.

The quantity  $r$  in Figure 5.5.2.1.2 is a characteristic foundation length that shall be determined as follows:

For  $\tilde{h}/L_o \leq 0.5$ ,

$$r = r_a = \sqrt{\frac{A_o}{T}} \quad (5.5.2.1.2-2)$$

For  $\tilde{h}/L_o \geq 1$ ,

$$r = r_m = \sqrt[4]{\frac{4I_o}{T}} \quad (5.5.2.1.2-3)$$

where:

$L_o$  = the overall length of the side of the foundation in the direction being analyzed,

$A_o$  = the area of the load-carrying foundation, and

$I_o$  = the static moment of inertia of the load-carrying foundation.

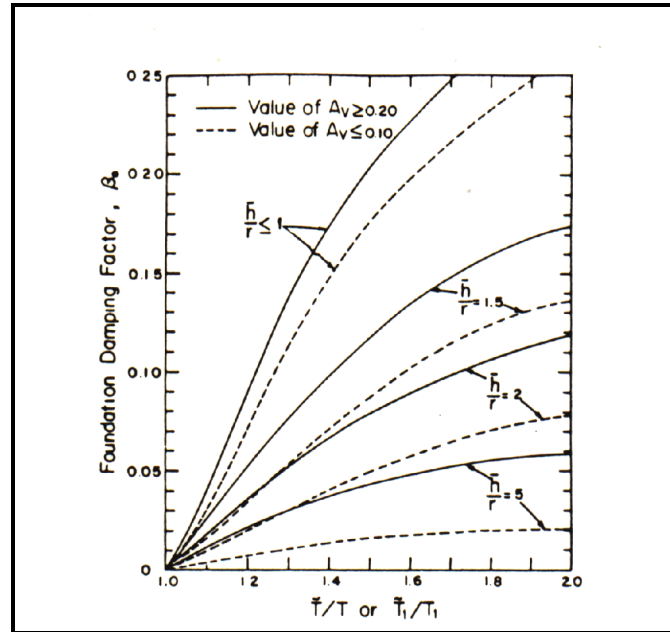

FIGURE 5.5.2.1.2 Foundation damping factor.

For intermediate values of  $\tilde{h}/L_o$ , the value of  $r$  shall be determined by linear interpolation.

**Exception:** For *structures* supported on point bearing piles and in all other cases where the foundation soil consists of a soft stratum of reasonably uniform properties underlain by a much stiffer, rock-like deposit with an abrupt increase in stiffness, the factor  $\beta_o$  in Eq. 5.5.2.1.2-1 shall be replaced by:

$$\beta_o = \left( \frac{4D_s}{V_s \tilde{T}} \right)^2 \beta_o \quad (5.5.2.1.2-4)$$

if  $4D_s/V_s \tilde{T} < 1$  where  $D_s$  is the total depth of the stratum.

The value of  $\tilde{\beta}$  computed from Eq. 5.5.2.1.2-1, both with or without the adjustment represented by Eq. 5.5.2.1.2-4, shall in no case be taken as less than  $\tilde{\beta} = 0.05$ .

**5.5.2.2 Vertical Distribution of Seismic Forces:** The distribution over the height of the *structure* of the reduced total *seismic force*,  $\tilde{V}$ , shall be considered to be the same as for the *structure* without interaction.

**5.5.2.3 Other Effects:** The modified *story shears*, overturning moments, and torsional effects about a vertical axis shall be determined as for *structures* without interaction using the reduced lateral forces.

The modified deflections,  $\tilde{x}$ , shall be determined as follows:

$$\tilde{\Delta}_x = \frac{\tilde{V}}{V} \left( \frac{M_o h_x}{K} + \Delta_x \right) \quad (5.5.2.3)$$

where:

$M_o$  = the overturning moment at the *base* determined in accordance with Sec. 5.3.6 using the unmodified *seismic forces* and not including the reduction permitted in the design of the foundation,

$h_x$  = the height above the *base* to the level under consideration, and

$\Delta_x$  = the deflections of the fixed-*base structure* as determined in Sec. 5.3.7.1 using the unmodified *seismic forces*.

The modified *story drifts* and *P-delta effects* shall be evaluated in accordance with the requirements of Sec. 5.3.7 using the modified *story shears* and deflections determined in this section.

**5.5.3 Modal Analysis Procedure:** The following requirements are supplementary to those presented in Sec. 5.4.

**5.5.3.1 Modal Base Shears:** To account for the effects of soil-*structure* interaction, the *base shear* corresponding to the fundamental mode of vibration,  $V_1$ , is permitted to be reduced to:

The reduction,  $\tilde{V}_1$ , shall be computed in accordance with Eq. 5.5.3.1-1

$\tilde{V}_1 = V_1 \left( \frac{W_1}{W} \right)^{0.75} \left( \frac{T_1}{T} \right)^{0.5}$  using the fundamental period of the fixed-*base structure*,  $T_1$ , and  $C_s$  computed from Eq. 5.4.5-3 using the fundamental period of the elastically supported *structure*,  $T_1$ .

The period  $T_1$  shall be determined from Eq. 5.5.2.1.1-1, or from Eq. 5.5.2.1.1-3 when applicable, taking  $T = T_1$ , evaluating  $\bar{k}$  from Eq. 5.5.2.1.1-2 with  $W = W_1$ , and computing  $\bar{h}$  as follows:

$$\bar{h} = \frac{\sum_{i=1}^n w_i \phi_{i1} h_i}{\sum_{i=1}^n w_i \phi_{i1}} \quad (5.5.3.1-2)$$

The above designated values of  $W$ ,  $\bar{h}$ ,  $T$ , and  $T_1$  also shall be used to evaluate the factor  $\rho$  from Eq. 5.5.2.1.1-4 and the factor  $\sigma$  from Figure 5.5.2.1.2. No reduction shall be made in the shear *components* contributed by the higher modes of vibration. The reduced *base shear*,  $\tilde{V}_1$ , shall in no case be taken less than  $0.7V_1$ .

**5.5.3.2 Other Modal Effects:** The modified modal *seismic forces*, *story shears*, and overturning moments shall be determined as for *structures* without interaction using the modified *base shear*,  $\tilde{V}_1$ , instead of  $V_1$ . The modified modal deflections,  $\tilde{\Delta}_{xm}$ , shall be determined as follows:



$$\tilde{\Delta}_{x1} = \frac{\overline{V_1}}{V_1} \left[ \frac{M_o h_x}{K} + \Delta_{x1} \right] \quad (5.5.3.2-1)$$

and

$$\tilde{\Delta}_{xm} = \Delta_x \text{ for } m = 2, 3, \dots \quad (5.5.3.2-2)$$

where:

- $M_{o1}$  = the overturning *base* moment for the fundamental mode of the fixed-*base structure*, as determined in Sec. 5.4.7 using the unmodified modal *base shear*  $V_1$ , and
- $\Delta_{xm}$  = the modal deflections at Level  $x$  of the fixed-*base structure* as determined in Sec. 5.4.6 using the unmodified modal shears,  $V_m$ .

The modified modal drift in a *story*,  $\tilde{\Delta}_m$ , shall be computed as the difference of the deflections,  $\tilde{\Delta}_{xm}$ , at the top and bottom of the *story* under consideration.

**5.5.3.3 Design Values:** The design values of the modified shears, moments, deflections, and *story* drifts shall be determined as for *structures* without interaction by taking the square root of the sum of the squares of the respective modal contributions. In the design of the foundation, the overturning moment at the foundation-soil interface determined in this manner may be reduced by 10 percent as for *structures* without interaction.

The effects of torsion about a vertical axis shall be evaluated in accordance with the requirements of Sec. 5.3.5 and the *P*-delta effects shall be evaluated in accordance with the requirements of Sec. 5.3.7.2, using the *story shears* and drifts determined in Sec. 5.5.3.2.

## Chapter 6

### ARCHITECTURAL, MECHANICAL, AND

### ELECTRICAL COMPONENTS DESIGN REQUIREMENTS

**6.1 GENERAL:** This chapter establishes minimum design criteria for architectural, mechanical, electrical, and nonstructural systems, components, and elements permanently attached to *structures*, including supporting *structures* and attachments (hereinafter referred to as "components"). The design criteria establish minimum equivalent static force levels and relative displacement demands for the design of components and their attachments to the *structure*, recognizing ground motion and structural amplification, component toughness and weight, and performance expectations.

This chapter also establishes minimum seismic design force requirements for *nonbuilding structures* that are supported by other *structures*. Seismic design requirements for *nonbuilding structures* that are supported at grade are prescribed in Chapter 14. However, the minimum seismic design forces for *nonbuilding structures* that are supported by another *structure* shall be determined in accordance with the requirements of Sec. 6.1.3 with  $R_p$  equal to the value of  $R$  specified in Chapter 14 and  $a_p = 2.5$  for *nonbuilding structures* with flexible dynamic characteristics and  $a_p = 1.0$  for *nonbuilding structures* with rigid dynamic characteristics. The distribution of lateral forces for the supported *nonbuilding structure* and all nonforce requirements specified in Chapter 14 shall apply to supported *nonbuilding structures*.

**Exception:** For *structures* in *Seismic Design Categories* D, E and F if the combined weight of the supported components and *nonbuilding structures* with flexible dynamic characteristics exceeds 25 percent of the weight of the *structure*, the *structure* shall be designed considering interaction effects between the *structure* and the supported items.

*Seismic Design Categories* for *structures* are defined in Sec. 4.2. For the purposes of this chapter, components shall be considered to have the same *Seismic Design Category* as that of the *structure* that they occupy or to which they are attached unless otherwise noted.

In addition, all components are assigned a component importance factor ( $I_p$ ) in this chapter. The default value for  $I_p$  is 1.00 for typical components in normal service. Higher values for  $I_p$  are assigned for components which contain hazardous substances, must have a higher level of assurance of function, or otherwise require additional attention because of their life-safety characteristics. Component importance factors are prescribed in Sec. 6.1.5.

All architectural, mechanical, electrical, and other nonstructural components in *structures* shall be designed and constructed to resist the equivalent static forces and displacements determined in accordance with this chapter. The design and evaluation of support *structures* and architectural components and equipment shall consider their flexibility as well as their strength.

**Exception:** The following components are exempt from the requirements of this chapter:

1. All components in *Seismic Design Category A*,
2. Architectural components in *Seismic Design Category B* other than parapets supported by bearing walls or shear walls when the importance factor ( $I_p$ ) is equal to 1.00,
3. Mechanical and electrical components in *Seismic Design Category B*,
4. Mechanical and electrical components in *Seismic Design Category C* when the importance factor ( $I_p$ ) is equal to 1.00,
5. Mechanical and electrical components in *Seismic Design Categories D, E, and F* that are mounted at 4 ft (1.22 m) or less above a floor level and weigh 400 lb (1780 N) or less and are not critical to the continued operation of the structure, or
6. Mechanical and electrical components in *Seismic Design Categories C, D, E, and F* that weigh 20 lb (95 N) or less or, for distribution systems, weight 5 lb/ft (7 N/m) or less.

The functional and physical interrelationship of components and their effect on each other shall be considered so that the failure of an essential or nonessential architectural, mechanical, or electrical component shall not cause the failure of an essential architectural, mechanical, or electrical component

## **6.1.1 REFERENCES AND STANDARDS:**

**6.1.1.1 Consensus Standards:** The following references are consensus standards and are to be considered part of these provisions to the extent referred to in this chapter:

- Ref. 6-1 American Society of Mechanical Engineers (ASME), ASME A17.1, *Safety Code For Elevators And Escalators*, 1996.
- Ref. 6-2 American Society For Testing And Materials (ASTM), ASTM C635, *Standard Specification for the Manufacture, Performance, and Testing of Metal Suspension Systems for Acoustical Tile and Lay-in Panel Ceilings*, 1995.
- Ref. 6-3 American Society for Testing and Materials (ASTM), ASTM C636, *Standard Practice for Installation of Metal Ceiling Suspension Systems for Acoustical Tile and Lay-in Panels*, 1992.
- Ref. 6-4 American National Standards Institute/American Society of Mechanical Engineers, ANSI/ASME B31.1-95, *Power Piping*
- Ref. 6-5 American National Standards Institute/American Society of Mechanical Engineers, ANSI/ASME B31.3-96, *Process Piping*
- Ref. 6-7 American National Standards Institute/American Society of Mechanical Engineers, ANSI/ASME B31.4-92, *Liquid Transportation Systems for Hydrocarbons, Liquid Petroleum Gas, Anhydrous Ammonia, and Alcohols*
- Ref. 6-8 American National Standards Institute/American Society of Mechanical Engineers, ANSI/ASME B31.5-92, *Refrigeration Piping*

- Ref. 6-9 American National Standards Institute/American Society of Mechanical Engineers, ANSI/ASME B31.9-95, *Building Services Piping*
- Ref. 6-10 American National Standards Institute/American Society of Mechanical Engineers, ANSI/ASME B31.11-86, *Slurry Transportation Piping Systems*
- Ref. 6-11 American National Standards Institute/American Society of Mechanical Engineers, ANSI/ASME B31.8-95, *Gas Transmission and Distribution Piping Systems*
- Ref. 6-12 National Fire Protection Association (NFPA), NFPA-13, *Standard for the Installation of Sprinkler Systems*, 1996.

**6.1.1.2 Accepted Standards:** The following references are standards developed within the industry and represent acceptable procedures for design and construction:

- Ref. 6-13 American Society of Heating, Ventilating, and Air Conditioning (ASHRAE), *Handbook*, Chapter 50, “Seismic Restraint Design,” 1995.
- Ref. 6-14 Ceilings and Interior Systems Construction Association (CISCA), *Recommendations for Direct-Hung Acoustical Tile and Lay-in Panel Ceilings, Seismic Zones 0-2*, 1991.
- Ref. 6-15 Ceilings and Interior Systems Construction Association (CISCA), *Recommendations for Direct-Hung Acoustical Tile and Lay-in Panel Ceilings, Seismic Zones 3-4*, 1990.
- Ref. 6-16 Sheet Metal and Air Conditioning Contractors National Association (SMACNA), *HVAC Duct Construction Standards, Metal and Flexible*, 1985.
- Ref. 6-17 Sheet Metal and Air Conditioning Contractors National Association (SMACNA), *Rectangular Industrial Duct Construction Standards*, 1980.
- Ref. 6-18 Sheet Metal and Air Conditioning Contractors National Association (SMACNA), *Seismic Restraint Manual Guidelines for Mechanical Systems*, 1991, including Appendix E, 1993 addendum.

**6.1.2 COMPONENT FORCE TRANSFER:** Components shall be attached such that the component forces are transferred to the *structure* of the building. Component seismic attachments shall be bolted, welded, or otherwise positively fastened without consideration of frictional resistance produced by the effects of gravity.

The design documents shall include sufficient information relating to the attachments to verify compliance with the requirements of this chapter.

**6.1.3 SEISMIC FORCES:** Seismic forces ( $F_p$ ) shall be determined in accordance with Eq. 6.1.3-1:

$$F_p = \frac{0.4 a_p S_{DS} W_p}{\frac{R_p}{I_p}} \left( 1 + 2 \frac{z}{h} \right) \quad (6.1.3-1)$$

$F_p$  is not required to be taken as greater than:

$$F_p = 1.6 S_{DS} I_p W_p \quad (6.1.3-2)$$

and  $F_p$  shall not be taken as less than:

$$F_p = 0.3 S_{DS} I_p W_p \quad (6.1.3-3)$$

where:

$F_p$  = Seismic design force centered at the component's center of gravity and distributed relative to component's mass distribution.

$S_{DS}$  = Spectral acceleration, short period, as determined from Sec. 4.1.2.5.

$a_p$  = Component amplification factor that varies from 1.00 to 2.50 (select appropriate value from Table 6.2.2 or Table 6.3.2).

$I_p$  = Component importance factor that is either 1.00 or 1.50 (see Sec. ).

$W_p$  = Component operating weight.

$R_p$  = Component response modification factor that varies from 1.0 to 5.0 (select appropriate value from Table 6.2.2 or Table 6.3.2).

$z$  = Height in *structure* of highest point of attachment of component. For items at or below the base,  $z$  shall be taken as 0.

$h$  = Average roof height of *structure* relative to grade elevation.

The force ( $F_p$ ) shall be applied independently longitudinally and laterally in combination with service loads associated with the component. Combine horizontal and vertical load effects as indicated in Sec. 5.2.7 substituting  $F_p$  for the term  $Q_E$ . The reliability/redundancy factor,  $\phi$ , is permitted to be taken equal to 1.

When positive and negative wind loads exceed  $F_p$  for nonstructural exterior walls, these wind loads shall govern the design. Similarly when the building code horizontal loads exceed  $F_p$  for interior partitions, these building code loads shall govern the design.

**6.1.4 SEISMIC RELATIVE DISPLACEMENTS:** Seismic relative displacements ( $D_p$ ) shall be determined in accordance with the following equations:

For two connection points on the same *Structure A* or the same structural system, one at level  $x$  and the other at level  $y$ ,  $D_p$  shall be determined as:

$$D_p = \delta_{xA} - \delta_{yA} \quad (6.1.4-1)$$

$D_p$  is not required to be taken as greater than:

$$D_p = (X - Y) \frac{\Delta_{aA}}{h_{sx}} \quad (6.1.4-2)$$

For two connection points on separate *Structures* A and B or separate structural systems, one at level  $x$  and the other at level  $y$ ,  $D_p$  shall be determined as:

$$D_p = |x_A| + |y_B| \quad (6.1.4-3)$$

$D_p$  is not required to be taken as greater than:

$$D_p = \frac{X\Delta_{aA}}{h_{sx}} + \frac{Y\Delta_{aB}}{h_{sx}} \quad (6.1.4-4)$$

where:

- $D_p$  = Relative seismic displacement that the component must be designed to accommodate.
- $x_A$  = Deflection at building level  $x$  of *Structure* A, determined by an elastic analysis as defined in Sec. 5.2.8.1 and multiplied by the  $C_d$  factor.
- $y_A$  = Deflection at building level  $y$  of *Structure* A, determined by an elastic analysis as defined in Sec. 5.2.8.1 and multiplied by the  $C_d$  factor.
- $y_B$  = Deflection at building level  $y$  of *Structure* B, determined by an elastic analysis as defined in Sec. 5.2.8.1 and multiplied by the  $C_d$  factor.
- $X$  = Height of upper support attachment at level  $x$  as measured from the base.
- $Y$  = Height of lower support attachment at level  $y$  as measured from the base.
- $a_A$  = Allowable story drift for *Structure* A as defined in Table 5.2.8.
- $a_B$  = Allowable story drift for *Structure* B as defined in Table 5.2.8.
- $h_{sx}$  = Story height used in the definition of the allowable drift,  $a$ , in Table 5.2.8. Note that  $a/h_{sx}$  = the allowable drift index.

The effects of seismic relative displacements shall be considered in combination with displacements caused by other loads as appropriate.

**6.1.5 COMPONENT IMPORTANCE FACTOR:** The component importance factor ( $I_p$ ) shall be selected as follows:

- $I_p = 1.5$  Life-safety component is required to function after an earthquake.
- $I_p = 1.5$  Component contains *hazardous contents*.
- $I_p = 1.5$  Storage racks in occupancies open to the general public (e.g., warehouse retail stores).
- $I_p = 1.0$  All other components.

In addition, for *structures* in *Seismic Use Group III*:

- $I_p = 1.5$  All components needed for continued operation of the facility or whose failure could impair the continued operation of the facility.

**6.1.6 COMPONENT ANCHORAGE:** Components shall be anchored in accordance with the following provisions.

**6.1.6.1:** The force in the connected part shall be determined based on the prescribed forces for the component specified in Sec. 6.1.3. Where component anchorage is provided by expansion anchors, shallow chemical anchors or shallow (low deformability) cast-in-place anchors, a value of  $R_p = 1.5$  shall be used in Sec. 6.1.3 to determine the forces in the connected part.

**6.1.6.2:** Anchors embedded in concrete or masonry shall be proportioned to carry the least of the following:

- a. The design strength of the connected part,
- b. 2 times the force in the connected part due to the prescribed forces, and
- c. The maximum force that can be transferred to the connected part by the component structural system.

**6.1.6.3:** Determination of forces in anchors shall take into account the expected conditions of installation including eccentricities and prying effects.

**6.1.6.4:** Determination of force distribution of multiple anchors at one location shall take into account the stiffness of the connected system and its ability to redistribute loads to other anchors in the group beyond yield.

**6.1.6.5:** Powder driven fasteners shall not be used for tension load applications in *Seismic Design Categories* D, E, and F unless approved for such loading.

**6.1.6.6:** The design strength of anchors in concrete shall be determined in accordance with the provisions of Chapter 9.

**6.1.6.7:** For additional requirements for anchors to steel, see Chapter 10.

**6.1.6.8:** For additional requirements for anchors in masonry, see Chapter 11.

**6.1.6.9:** For additional requirements for anchors in wood, see Chapter 12.

**6.1.7 CONSTRUCTION DOCUMENTS:** Construction documents shall be prepared by a registered design professional in a manner consistent with the requirements of these *Provisions*, as indicated in Table 6.1.7, in sufficient detail for use by the *owner*, building officials, contractors, and inspectors.

**Table 6.1.7**  
**Construction Documents**

Component Description	Provisions Reference		Required Seismic Design Categories
	Quality Assurance	Design	
Exterior nonstructural wall elements, including anchorage	3.2.8 No. 1	6.2.4	D, E
Suspended ceiling system, including anchorage	3.2.8 No. 3	6.2.6	D, E
Access floors, including anchorage	3.8 No. 2	6.2.7	D, E

**Table 6.1.7**  
**Construction Documents**

Component Description	Provisions Reference		Required Seismic Design Categories
	Quality Assurance	Design	
Steel storage racks, including anchorage	3.2.8 No. 2	6.2.9	D, E
HVAC ductwork containing hazardous materials, including anchorage	3.2.9 No. 4	6.3.10	C, D, E
Piping systems and mechanical units containing flammable, combustible, or highly toxic materials	3.2.9 No. 3	6.3.11 6.3.12 6.3.13	C, D, E
Anchorage of electrical equipment for emergency or standby power systems	3.2.9 No. 1	6.3.14	C, D, E
Anchorage of all other electrical equipment	3.2.9 No. 2	6.3.14	E
Project-specific requirements for mechanical and electrical components and their anchorage	3.3.5	6.30	C, D, E

**6.2 ARCHITECTURAL COMPONENT DESIGN:**

**6.2.1 GENERAL:** Architectural systems, components, or elements (hereinafter referred to as "components") listed in Table 6.2.2 and their attachments shall meet the requirements of Sec. 6.2.2 through Sec. 6.2.9.

**6.2.2 ARCHITECTURAL COMPONENT FORCES AND DISPLACEMENTS:** Architectural components shall meet the force requirements of Sec. 6.1.3 and 6.4 and Table 6.2.2.

**Exception:** Components supported by chains or otherwise suspended from the structural system above are not required to meet the lateral seismic force requirements and seismic relative displacement requirements of this section provided that they cannot be damaged or cannot damage any other component when subject to seismic motion and they have ductile or articulating connections to the *structure* at the point of attachment. The gravity design load for these items shall be three times their operating load.

**TABLE 6.2.2**  
**Architectural Components Coefficients**

Architectural Component or Element	$a_p^a$	$R_p^b$
Interior Nonstructural Walls and Partitions (See also Sec. 6.8)		
Plain (unreinforced) masonry walls	1.0	1.25
All other walls and partitions	1.0	2.5



Architectural Component or Element	$a_p^a$	$R_p^b$
Cantilever Elements (Unbraced or braced to structural frame below its center of mass) Parapets and cantilever interior nonstructural walls Chimneys and stacks where laterally supported by <i>structures</i>	2.5 2.5	2.5 2.5
Cantilever Elements (Braced to structural frame above its center of mass) Parapets Chimneys and Stacks Exterior Nonstructural Walls	1.0 1.0 1.0 <sup>c</sup>	2.5 2.5 2.5
Exterior Nonstructural Wall Elements and Connections (see also Sec. 6.2.4) Wall Element Body of wall panel connections Fasteners of the connecting system	1.0 1.0 1.25	2.5 2.5 1
Veneer High deformability elements and attachments Low deformability elements and attachments	1.0 1.0	2.5 1.25
Penthouses (except when framed by an extension of the building frame)	2.5	3.5
Ceilings (see also Sec. 6.2.6) All	1.0	2.5
Cabinets Storage cabinets and laboratory equipment	1.0	2.5
Access floors (see also Sec. 6.2.7) Special access floors (designed in accordance with Sec. 6.2.7.2) All other	1 1	2.5 1.25
Appendages and Ornamentations	2.5	2.5
Signs and Billboards	2.5	2.5
Other Rigid Components High deformability elements and attachments Limited deformability elements and attachments Low deformability elements and attachments	1.0 1.0 1.0	3.5 2.5 1.25
Other flexible components High deformability elements and attachments Limited deformability elements and attachments Low deformability elements and attachments	2.5 2.5 2.5	3.5 2.5 1.25

<sup>a</sup> A lower value for  $a_p$  may be justified by detailed dynamic analysis. The value for  $q$  shall not be less than 1.00. The value of  $a_p = 1$  is for equipment generally regarded as rigid and rigidly attached. The value of  $q = 2.5$  is for flexible components or flexibly attached components. See Chapter 2 for definitions of rigid and flexible components including attachments.

<sup>b</sup>  $R_p = 1.25$  for anchorage design when component anchorage is provided by expansion anchor bolts, shallow chemical anchors, or shallow (nonductile) cast-in-place anchors or when the component is constructed of nonductile materials. Powder-actuated fasteners (shot pins) shall not be used for component anchorage in tension applications in *Seismic Design Categories* D, E, or F. Shallow anchors are those with an embedment length-to-diameter ratio of less than 8.

<sup>c</sup> Where flexible diaphragms provide lateral support for walls and partitions, the design forces for anchorage to the diaphragm shall be as specified in Sec. 5.2.5.4.4.

**6.2.3 ARCHITECTURAL COMPONENT DEFORMATION:** Architectural components that could pose a life-safety hazard shall be designed for the seismic relative displacement requirements of Sec. 6.1.4. Architectural components shall be designed for vertical deflection due to joint rotation of cantilever structural members.

**6.2.4 EXTERIOR NONSTRUCTURAL WALL ELEMENTS AND CONNECTIONS:**

Exterior nonstructural wall panels or elements that are attached to or enclose the *structure* shall be designed to resist the forces in accordance with Eq. 6.1.3-1 or 6.1.3-2, and shall accommodate movements of the *structure* resulting from response to the design basis ground motion,  $D_p$  or temperature changes. Such elements shall be supported by means of positive and direct structural supports or by mechanical connections and fasteners in accordance with the following requirements:

- a. Connections and panel joints shall allow for a relative movement between stories of not less the calculated story drift  $D_p$ , or 1/2 inch (13 mm), whichever is greatest.
- b. Connections to permit movement in the plane of the panel for story drift shall be sliding connections using slotted or oversize holes, connections that permit movement by bending of steel, or other connections that provide equivalent sliding or ductile capacity.
- c. Bodies of connectors shall have sufficient deformability and rotation capacity to preclude fracture of the concrete or low deformation failures at or near welds.
- d. All fasteners in the connecting system such as bolts, inserts, welds, and dowels and the body of the connectors shall be designed for the force ( $F_p$ ) determined in by Eq. 6.1.3-2 with values of  $R_p$  and  $a_p$  taken from Table 6.2.2 applied at the center of mass of the panel.
- e. Anchorage using flat straps embedded in concrete or masonry shall be attached to or hooked around reinforcing steel or otherwise terminated so as to effectively transfer forces to the reinforcing steel.

**6.2.5 OUT-OF-PLANE BENDING:** Transverse or out-of-plane bending or deformation of a component or system that is subjected to forces as determined in Sec. 6.1.3 shall not exceed the deflection capability of the component or system.

**6.2.6 SUSPENDED CEILING:** Suspended ceilings shall be designed to meet the seismic force requirements of Sec. 6.2.6.1. In addition, suspended ceilings shall meet the requirements of either Industry Standard Construction as modified in Sec. 6.2.6.2 or Integral Construction as specified in Sec. 6.2.6.3.

**6.2.6.1 Seismic Forces:** Suspended ceilings shall be designed to meet the force requirements of Sec. 6.1.3.

The weight of the ceiling,  $W_p$ , shall include the ceiling grid and panels; light fixtures if attached to, clipped to, or laterally supported by the ceiling grid; and other components which are laterally supported by the ceiling.  $W_p$  shall be taken as not less than 4 pounds per square foot (19 N/m<sup>2</sup>)

The seismic force,  $F_p$ , shall be transmitted through the ceiling attachments to the building structural elements or the ceiling-*structure* boundary.

Design of anchorage and connections shall be in accordance with these provisions.

**6.2.6.2 Industry Standard Construction:** Unless designed in accordance with Sec. 6.2.6.3, suspended ceilings shall be designed and constructed in accordance with this section.

**6.2.6.2.1 Seismic Design Category C:** Suspended ceilings in Seismic Design Category C shall be designed and installed in accordance with the Ceilings and Interior Systems Construction Association (CISCA) recommendations for seismic zones 0-2 (Ref. 6-14), except that seismic forces shall be determined in accordance with Sec. 6.1.3 and 6.2.6.1.

Sprinkler heads and other penetrations in Seismic Design Category C shall have a minimum of 1/4 inch (6 mm) clearance on all sides.

**6.2.6.2.2 Seismic Design Categories D, E, and F:** Suspended ceilings in *Seismic Design Categories* D, E, and F shall be designed and installed in accordance with the Ceilings and Interior Systems Construction Association (CISCA) recommendations for seismic zones 3-4 (Ref. 6-15) and the additional requirements listed in this subsection.

- a. A heavy duty T-bar grid system shall be used.
- b. The width of the perimeter supporting closure angle shall be not less than 2.0 inches (50 mm). In each orthogonal horizontal direction, one end of the ceiling grid shall be attached to the closure angle. The other end in each horizontal direction shall have a 3/4 inch (19 mm) clearance from the wall and shall rest upon and be free to slide on a closure angle.
- c. For ceiling areas exceeding 1000 square feet (92.9 m<sup>2</sup>), horizontal restraint of the ceiling to the structural system shall be provided. The tributary areas of the horizontal restraints shall be approximately equal.

**Exception:** Rigid braces are permitted to be used instead of diagonal splay wires. Braces and attachments to the structural system above shall be adequate to limit relative lateral deflections at point of attachment of ceiling grid to less than 1/4 inch (6 mm) for the loads prescribed in Sec. 6.1.3

- d. For ceiling areas exceeding 2500 square feet (232 m<sup>2</sup>), a seismic separation joint or full height partition that breaks the ceiling up into areas not exceeding 2500 square feet shall be provided unless structural analyses are performed of the ceiling bracing system for the prescribed seismic forces which demonstrate ceiling system penetrations and closure angles provide sufficient clearance to accommodate the additional movement. Each area shall be provided with closure angles in accordance with Item b and horizontal restraints or bracing in accordance with Item c.
- e. Except where rigid braces are used to limit lateral deflections, sprinkler heads and other penetrations shall have a 2 inch (50 mm) oversize ring, sleeve, or adapter through the ceiling tile to

allow for free movement of at least 1 inch (25 mm) in all horizontal directions. Alternatively, a swing joint that can accommodate 1 inch (25 mm) of ceiling movement in all horizontal directions are permitted to be provided at the top of the sprinkler head extension.

- f. Changes in ceiling plan elevation shall be provided with positive bracing.
- g. Cable trays and electrical conduits shall be supported independently of the ceiling.
- h. Suspended ceilings shall be subject to the special inspection requirements of Sec. 3.3.9 of these *Provisions*.

**6.2.6.3 Integral Ceiling/Sprinkler Construction:** As an alternate to providing large clearances around sprinkler system penetrations through ceiling systems, the sprinkler system and ceiling grid are permitted to be designed and tied together as an integral unit. Such a design shall consider the mass and flexibility of all elements involved, including: ceiling system, sprinkler system, light fixtures, and mechanical (HVAC) appurtenances. The design shall be performed by a *registered design professional*.

## 6.2.7 ACCESS FLOORS:

**6.2.7.1 General:** Access floors shall be designed to meet the force provisions of Sec. 6.1.3 and the additional provisions of this section. The weight of the access floor,  $W_p$ , shall include the weight of the floor system, 100 percent of the weight of all equipment fastened to the floor, and 25 percent of the weight of all equipment supported by, but not fastened to the floor. The seismic force,  $F_p$ , shall be transmitted from the top surface of the access floor to the supporting *structure*.

Overtopping effects of equipment fastened to the access floor panels also shall be considered. The ability of "slip on" heads for pedestals shall be evaluated for suitability to transfer overturning effects of equipment.

When checking individual pedestals for overturning effects, the maximum concurrent axial load shall not exceed the portion of  $W_p$  assigned to the pedestal under consideration.

**6.2.7.2 Special Access Floors:** Access floors shall be considered to be "special access floors" if they are designed to comply with the following considerations:

1. Connections transmitting seismic loads consist of mechanical fasteners, concrete anchors, welding, or bearing. Design load capacities comply with recognized design codes and/or certified test results.
2. Seismic loads are not transmitted by friction produced solely by the effects of gravity, powder-actuated fasteners (shot pins), or adhesives.
3. The bracing system shall be designed considering the destabilizing effects of individual members buckling in compression.
4. Bracing and pedestals are of structural or mechanical shape produced to ASTM specifications that specify minimum mechanical properties. Electrical tubing shall not be used.
5. Floor stringers that are designed to carry axial seismic loads and that are mechanically fastened to the supporting pedestals are used.

**6.2.8 PARTITIONS:** Partitions that are tied to the ceiling and all partitions greater than 6 ft (1.8 m) in height shall be laterally braced to the building *structure*. Such bracing shall be independent of any ceiling splay bracing. Bracing shall be spaced to limit horizontal deflection at the partition head to be compatible with ceiling deflection requirements as determined in Sec. 6.2.6 for suspended ceilings and Sec. 6.2.2 for other systems.

**6.2.9 STEEL STORAGE RACKS:** Steel storage racks shall be designed to meet the force requirements of Chapter 14:

### 6.3 MECHANICAL AND ELECTRICAL COMPONENT DESIGN:

**6.3.1 GENERAL:** Attachments and equipment supports for the mechanical and electrical systems, components, or elements (hereinafter referred to as "components") shall meet the requirements of Sec. 6.3.2 through Sec. 6.3.16.

**6.3.2 MECHANICAL AND ELECTRICAL COMPONENT FORCES AND DISPLACEMENTS:** Mechanical and electrical components shall meet the force and seismic relative displacement requirements of Sec. 6.1.3, Sec. 6.1.4, and Table 6.3.2.

Some complex equipment such as valves and valve operators, turbines and generators, and pumps and motors are permitted to be functionally connected by mechanical links not capable of transferring the seismic loads or accommodating seismic relative displacements and may require special design considerations such as a common rigid support or skid.

**Exception:** Components supported by chains or similarly suspended *structure* above are not required to meet the lateral seismic force requirements and seismic relative displacement requirements of this section provided that they cannot be damaged or cannot damage any other component when subject to seismic motion and they have high deformation or articulating connections to the building at the point of attachment. The gravity design load for these items shall be three times their operating load.

**TABLE 6.3.2**  
**Mechanical and Electrical Components Coefficients**

Mechanical and Electrical Component or Element <sup>c</sup>	$a_p^a$	$R_p^b$
General Mechanical		
Boilers and furnaces	1.0	2.5
Pressure vessels on skirts and free-standing	2.5	2.5
Stacks	2.5	2.5
Cantilevered chimneys	2.5	2.5
Other	1.0	2.5
Manufacturing and Process Machinery		
General	1.0	2.5
Conveyors (nonpersonnel)	2.5	2.5
Piping Systems		
High deformability elements and attachments	1.0	3.5
Limited deformability elements and attachments	1.0	2.5
Low deformability elements or attachments	1.0	1.25

Mechanical and Electrical Component or Element <sup>c</sup>	$a_p^a$	$R_p^b$
HVAC System Equipment		
Vibration isolated	2.5	2.5
Nonvibration isolated	1.0	2.5
Mounted in-line with ductwork	1.0	2.5
Other	1.0	2.5
Elevator Components	1.0	2.5
Escalator Components	1.0	2.5
Trussed Towers (free-standing or guyed)	2.5	2.5
General Electrical		
Distributed systems (bus ducts, conduit, cable tray)	2.5	5
Equipment	1.0	2.5
Lighting Fixtures	1.0	1.25

<sup>a</sup> A lower value for  $a_p$  is permitted provided a detailed dynamic analysis is performed which justifies a lower limit. The value for  $a_p$  shall not be less than 1.00. The value of  $a_p = 1$  is for equipment generally regarded as rigid or rigidly attached. The value of  $a_p = 2.5$  is for flexible components or flexibly attached components. See Chapter 2 for definitions of rigid and flexible components including attachments.

<sup>b</sup>  $R_p = 1.25$  for anchorage design when component anchorage is provided by expansion anchor bolts, shallow chemical anchors, or shallow low deformability cast-in-place anchors or when the component is constructed of nonductile materials. Powder-actuated fasteners (shot pins) shall not be used for component anchorage in *Seismic Design Categories* D, E, or F. Shallow anchors are those with an embedment length-to-diameter ratio of less than 8.

<sup>c</sup> Components mounted on vibration isolation systems shall have a bumper restraint or snubber in each horizontal direction. The design force shall be taken as  $2F_p$ .

**6.3.3 MECHANICAL AND ELECTRICAL COMPONENT PERIOD:** The fundamental period of the mechanical and electrical component (and its attachment to the building),  $T_p$ , may be determined by the following equation provided that the component and attachment can be reasonably represented analytically by a simple spring and mass single-degree-of-freedom system:

$$T_p = 2 \sqrt{\frac{W_p}{K_p g}} \quad (6.3.3)$$

where:

$T_p$  = Component fundamental period,

$W_p$  = Component operating weight,

$g$  = Gravitational acceleration, and

$K_p$  = Stiffness of resilient support system of the component and attachment, determined in terms of load per unit deflection at the center of gravity of the component.

Note that consistent units must be used.

Alternatively, determine the fundamental period of the component in seconds ( $T_p$ ) from experimental test data or by a properly substantiated analysis.

**6.3.4 MECHANICAL AND ELECTRICAL COMPONENT ATTACHMENTS:** The stiffness of mechanical and electrical component attachments shall be designed such that the load path for the component performs its intended function.

**6.3.5 COMPONENT SUPPORTS:** Mechanical and electrical component supports and the means by which they are attached to the component shall be designed for the forces determined in Sec. 6.1.3 and in conformance with Chapters 5 through 9, as appropriate, for the materials comprising the means of attachment. Such supports include structural members, braces, frames, skirts, legs, saddles, pedestals, cables, guys, stays, snubbers, and tethers. Component supports may be forged or cast as a part of the mechanical or electrical component. If standard or proprietary supports are used, they shall be designed by either load rating (i.e., testing) or for the calculated seismic forces. In addition, the stiffness of the support, when appropriate, shall be designed such that the seismic load path for the component performs its intended function.

Component supports shall be designed to accommodate the seismic relative displacements between points of support determined in accordance with Sec. 6.1.4.

In addition, the means by which supports are attached to the component, except when integral (i.e., cast or forged), shall be designed to accommodate both the forces and displacements determined in accordance with Sec. 6.1.3 and 6.1.4. If the value of  $I_p = 1.5$  for the component, the local region of the support attachment point to the component shall be evaluated for the effect of the load transfer on the component wall.

**6.3.6 COMPONENT CERTIFICATION:** The manufacturer's certificate of compliance with the force requirements of the *Provisions* shall be submitted to the regulatory agency when required by the contract documents or when required by the regulatory agency.

**6.3.7 UTILITY AND SERVICE LINES AT STRUCTURE INTERFACES:** At the interface of adjacent *structures* or portions of the same *structure* that may move independently, utility lines shall be provided with adequate flexibility to accommodate the anticipated differential movement between the ground and the *structure*. Differential displacement calculations shall be determined in accordance with Sec. 6.1.4.

**6.3.8 SITE-SPECIFIC CONSIDERATIONS:** The possible interruption of utility service shall be considered in relation to designated seismic systems in *Seismic Use Group III* as defined in Sec. 1.3.1. Specific attention shall be given to the vulnerability of underground utilities and utility interfaces between the *structure* and the ground in all situations where *Site Class E* or *F* soil is present and where the seismic coefficient  $C_a$  is equal to or greater than 0.15.

### **6.3.9 STORAGE TANKS:**

**6.3.9.1 Above-Grade Storage Tanks:** For storage tanks mounted above grade in *structures*, attachments, supports, and the tank shall be designed to meet the force requirements of Chapter 14.

**6.3.10 HVAC DUCTWORK:** Attachments and supports for HVAC ductwork systems shall be designed to meet the force and displacement requirements of Sec. 6.1.3 and 6.1.4 and the additional requirements of this section. In addition to their attachments and supports, ductwork systems designated as having an  $I_p$  greater than 1.0 shall be designed to meet the force and displacement requirements of Sec. 6.1.3 and 6.1.4 and the additional requirements of this section. Where HVAC ductwork runs between *structures* that could displace relative to one another and for isolated

*structures* where the HVAC ductwork crosses the isolation interface, the HVAC ductwork shall be designed to accommodate the seismic relative displacements specified in Sec. 6.1.4.

Seismic restraints are not required for HVAC ducts with  $I_p = 1.0$  if either of the following conditions are met for the full length of each duct run:

- a. HVAC ducts are suspended from hangers, and all hangers are 12 in. (305 mm) or less in length from the top of the duct to the supporting *structure* and the hangers are detailed to avoid significant bending of the hangers and their attachments.

or

- b. HVAC ducts have a cross-sectional area of less than  $6 \text{ ft}^2$  ( $0.557 \text{ m}^2$ ).

HVAC duct systems fabricated and installed in accordance with the SMACNA duct construction standards (Ref. 6-16, 6-17, and 6-18) shall be deemed to meet the lateral bracing requirements of this section.

Equipment items installed in-line with the duct system (e.g., fans, heat exchangers, and humidifiers) with an operating weight greater than 75 lb (334 N) shall be supported and laterally braced independently of the duct system and shall meet the force requirements of Sec. 6.1.3. Appurtenances such as dampers, louvers, and diffusers shall be positively attached with mechanical fasteners. Unbraced piping attached to in-line equipment shall be provided with adequate flexibility to accommodate differential displacements.

**6.3.11 PIPING SYSTEMS:** Attachments and supports for piping systems shall be designed to meet the force and displacement requirements of Sec. 6.1.3 and 6.1.4 and the additional requirements of this section. In addition to their attachments and supports, piping systems designated as having  $I_p$  greater than 1.0 themselves shall be designed to meet the force and displacement provisions of Sec. 6.1.3 and 6.1.4 and the additional requirements of this section. When piping systems are attached to *structures* that could displace relative to one another and for isolated *structures*, including foundations, where the piping system crosses the isolation interface, the piping system shall be designed to accommodate the seismic relative displacements specified in Sec. 6.1.4.

Seismic effects that shall be considered in the design of a piping system include the dynamic effects of the piping system, its contents, and, when appropriate, its supports. The interaction between the piping system and the supporting *structures*, including other mechanical and electrical equipment, shall also be considered.

See Sec. 6.3.16 for elevator system piping requirements.

**6.3.11.1 Fire Protection Sprinkler Systems:** Fire protection sprinkler systems designed and constructed in accordance with Ref. 6-12 shall be deemed to meet the force, displacement, and other requirements of this section provided that the seismic design force and displacement calculated in accordance with Ref. 6-12, multiplied by a factor of 1.4, is not less than that determined using these *Provisions*.

**6.3.11.2 Other Piping Systems.** The following documents have been adopted as national standards by the American National Standards Institute (ANSI), and are appropriate for use in the seismic design



of piping systems provided that the seismic design forces and displacements used are comparable to those determined using these *Provisions*.

**Exception:** Piping systems designated as having an  $I_p$  greater than 1.0 shall not be designed using the simplified analysis procedures of Ref. 6-9 (Sec. 919.4.1(a)).

The following requirements shall also be met for piping systems designated as having an  $I_p$  greater than 1.0

- a. Under design loads and displacements, piping shall not be permitted to impact other components.
- b. Piping shall accommodate the effects of relative displacements that may occur between piping support points on the *structure* or the ground, other mechanical and/or electrical equipment, and other piping.

**6.3.11.2.1 Supports and Attachments for Other Piping:** In addition to meeting the force, displacement, and other requirements of this section, attachments and supports for piping shall be subject to the following other requirements and limitations:

- a. Attachments shall be designed in accordance with Sec. 6.1.6 .
- b. Seismic supports are not required for:
  1. Piping supported by rod hangers provided that all hangers in the pipe run are 12 in. (305 mm) or less in length from the top of the pipe to the supporting *structure* and the pipe can accommodate the expected deflections. Rod hangers shall not be constructed in a manner that would subject the rod to bending moments.
  2. High deformability piping in *Seismic Design Categories* D, E, and F designated as having an  $I_p$  greater than 1.0 and a nominal pipe size of 1 in. (25 mm) or less when provisions are made to protect the piping from impact or to avoid the impact of larger piping or other mechanical equipment.
  3. High deformability piping in *Seismic Design Category* C designated as having an  $I_p$  greater than 1.0 and a nominal pipe size of 2 in. (51 mm) or less when provisions are made to protect the piping from impact or to avoid the impact of larger piping or other mechanical equipment.
  4. High deformability piping in *Seismic Design Categories* D, E, and F designated as having an  $I_p$  equal to 1.0 and a nominal pipe size of 3 in. (76 mm) or less.
- c. Seismic supports shall be constructed so that support engagement is maintained.

**6.3.12 BOILERS AND PRESSURE VESSELS:** Attachments and supports for boilers and pressure vessels shall be designed to meet the force and displacement provisions of Sec. 6.1.3 and 6.1.4 and the additional provisions of this section. In addition to their attachments and supports, boilers and pressure vessels designated as having an  $I_p = 1.5$  themselves shall be designed to meet the force and displacement provisions of Sec. 6.1.3 and 6.1.4.

Seismic effects that shall be considered in the design of a boiler or pressure vessel include the dynamic effects of the boiler or pressure vessel, its contents, and its supports; sloshing of liquid contents; loads

from attached components such as piping; and the interaction between the boiler or pressure vessel and its support.

**6.3.12.1 ASME Boilers and Pressure Vessels:** Boilers or pressure vessels designed in accordance with Ref. 6-9 shall be deemed to meet the force, displacement, and other requirements of this section. In lieu of the specific force and displacement provisions provided in the ASME code, the force and displacement provisions of Sec. 6.1.3 and 6.1.4 shall be used.

**6.3.12.2 Other Boilers and Pressure Vessels:** Boilers and pressure vessels designated as having an  $I_p = 1.5$  but not constructed in accordance with the provisions of Ref. 6-9 shall meet the following provisions:

- a. The design strength for seismic loads in combination with other service loads and appropriate environmental effects shall not exceed the following:
  - (1) For boilers and pressure vessels constructed with ductile materials (e.g., steel, aluminum or copper), 90 percent of the material minimum specified yield strength.
  - (2) For threaded connections in boilers or pressure vessels or their supports constructed with ductile materials, 70 percent of the material minimum specified yield strength.
  - (3) For boilers and pressure vessels constructed with nonductile materials (e.g., plastic, cast iron, or ceramics), 25 percent of the material minimum specified tensile strength.
  - (4) For threaded connections in boilers or pressure vessels or their supports constructed with nonductile materials, 20 percent of the material minimum specified tensile strength.
- b. Provisions shall be made to mitigate seismic impact for boiler and pressure vessel components constructed of nonductile materials or in cases where material ductility is reduced (e.g., low temperature applications).
- c. Boilers and pressure vessels shall be investigated to ensure that the interaction effects between them and other constructions are acceptable.

**6.3.12.3 Supports and Attachments for Boilers and Pressure Vessels:** Attachments and supports for boilers and pressure vessels shall meet the following provisions:

- a. Attachments and supports transferring seismic loads shall be constructed of materials suitable for the application and designed and constructed in accordance with nationally recognized structural code such as, when constructed of steel, Ref. 8-1 and 8-2.
- b. Attachments embedded in concrete shall be suitable for cyclic loads.
- c. Seismic supports shall be constructed so that support engagement is maintained.

**6.3.13 MECHANICAL EQUIPMENT ATTACHMENTS AND SUPPORTS:** Attachments and supports for mechanical equipment not covered in Sec. 6.3.8 through 6.3.12 or 6.3.16 shall be designed to meet the force and displacement requirements of Sec. 6.1.3 and 6.1.4 and the additional requirements of this section. In addition, mechanical equipment designated as having an  $I_p$  greater than 1.0 shall be designed to meet the force and displacement requirements of Sec. 6.1.3 and 6.1.4 and the additional requirements of this section.

When required, seismic effects that shall be considered in the design of mechanical equipment, attachments and their supports include the dynamic effects of the equipment, its contents, and when appropriate its supports. The interaction between the equipment and the supporting *structures*, including other mechanical and electrical equipment, shall also be considered.

**6.3.13.1 Mechanical Equipment:** Mechanical equipment having an  $I_p$  greater than 1.0 shall meet the following requirements.

- a . Provisions shall be made to eliminate seismic impact for equipment components vulnerable to impact, equipment components constructed of nonductile materials, or in cases where material ductility is reduced (e.g., low temperature applications).
- b . The possibility for loadings imposed on the equipment by attached utility or service lines due to differential motions of points of support from separate *structures* shall be evaluated.

In addition, components of mechanical equipment designated as having an  $I_p$  greater than 1.0 and containing sufficient material that would be hazardous if released shall themselves be designed for seismic loads. The design strength for seismic loads in combination with other service loads and appropriate environmental effects such as corrosion shall be based on the following:

- a. For mechanical equipment constructed with ductile materials (e.g., steel, aluminum, or copper), 90 percent of the equipment material minimum specified yield strength.
- b. For threaded connections in equipment constructed with ductile materials, 70 percent of the material minimum specified yield strength.
- c. For mechanical equipment constructed with nonductile materials (e.g., plastic, cast iron, or ceramics), 25 percent of the equipment material minimum tensile strength.
- d. For threaded connections in equipment constructed with nonductile materials, 20 percent of the material minimum specified yield strength.

**6.3.13.2 Attachments and Supports for Mechanical Equipment:** Attachments and supports for mechanical equipment shall meet the following requirements :

- a. Attachments and supports transferring seismic loads shall be constructed of materials suitable for the application and designed and constructed in accordance with a nationally recognized structural standard specification such as, when constructed of steel, Ref. 8-1 and 8-2.
- b. Friction clips shall not be used for anchorage attachment.
- c. Expansion anchors shall not be used for nonvibration isolated mechanical equipment rated over 10 hp (7.45 kW ).

**Exception:** Undercut expansion anchors are permitted.

- d. Supports shall be specifically evaluated if weak-axis bending of cold-formed support steel is relied on for the seismic load path.
  - e. Components mounted on vibration isolation systems shall have a bumper restraint or snubber in each horizontal direction, and vertical restraints shall be provided where required to resist overturning. Isolator housings and restraints shall be constructed of ductile materials. (See
-

additional design force requirements in Table 6.3.2.) A viscoelastic pad or similar material of appropriate thickness shall be used between the bumper and equipment item to limit the impact load.

- f. Seismic supports shall be constructed so that support engagement is maintained.

**6.3.14 ELECTRICAL EQUIPMENT ATTACHMENTS AND SUPPORTS:** Attachments and supports for electrical equipment shall be designed to meet the force and displacement requirements of Sec. 6.1.3 and 6.1.4 and the additional requirements of this section. In addition, electrical equipment designated as having  $I_p$  greater than 1.0 shall itself be designed to meet the force and displacement requirements of Sec. 6.1.3 and 6.1.4 and the additional requirements of this section.

Seismic effects that shall be considered in the design of other electrical equipment include the dynamic effects of the equipment, its contents, and when appropriate its supports. The interaction between the equipment and the supporting *structures*, including other mechanical and electrical equipment, shall also be considered. When conduit, cable trays, or similar electrical distribution components are attached to *structures* that could displace relative to one another and for isolated *structures* where the conduit or cable trays cross the isolation interface, the conduit or cable trays shall be designed to accommodate the seismic relative displacements specified in Sec. 6.1.4.

**6.3.14.1 Electrical Equipment:** Electrical equipment designated as having an  $I_p$  greater than 1.0 shall meet the following requirements:

- a. Provisions shall be made to eliminate seismic impact between the equipment and other components .
- b. Evaluate loading on the equipment imposed by attached utility or service lines which are also attached to separate *structures*.
- c. Batteries on racks shall have wrap-around restraints to ensure that the batteries will not fall off the rack. Spacers shall be used between restraints and cells to prevent damage to cases. Racks shall be evaluated for sufficient lateral load capacity.
- d. Internal coils of dry type transformers shall be positively attached to their supporting substructure within the transformer enclosure.
- e. Slide out components in electrical control panels, computer equipment, etc., shall have a latching mechanism to hold contents in place.
- f. Electrical cabinet design shall conform to the applicable National Electrical Manufacturers Association (NEMA) standards. Cut-outs in the lower shear panel that do not appear to have been made by the manufacturer and are judged to significantly reduce the strength of the cabinet shall be specifically evaluated.
- g. The attachment of additional external items weighing more than 100 pounds (445 N) shall be specifically evaluated if not provided by the manufacturer.

**6.3.14.2 Attachments and Supports for Electrical Equipment:** Attachments and supports for electrical equipment shall meet the following requirements:

- a. Attachments and supports transferring seismic loads shall be constructed of materials suitable for the application and designed and constructed in accordance with a nationally recognized structural standard specification such as, when constructed of steel, Ref. 5-1 and 5-2.
- b. Friction clips shall not be used for anchorage attachment.
- c. Oversized plate washers extending to the equipment wall shall be used at bolted connections through the base sheet metal if the base is not reinforced with stiffeners or not judged capable of transferring the required loads.
- d. Supports shall be specifically evaluated if weak-axis bending of light gage support steel is relied on for the seismic load path.
- e. The supports for linear electrical equipment such as cable trays, conduit, and bus ducts shall be designed to meet the force and displacement requirements of Sec. 6.1.3 and 6.1.4 if any of the following situations apply:
  - (1) Supports are cantilevered up from the floor;
  - (2) Supports include bracing to limit deflection;
  - (3) Supports are constructed as rigid welded frames;
  - (4) Attachments into concrete utilize nonexpanding insets, shot pins, or cast iron embedments;
  - (5) Attachments utilize spot welds, plug welds, or minimum size welds as defined by AISC.
- f. Components mounted on vibration isolation systems shall have a bumper restraint or snubber in each horizontal direction, and vertical restraints shall be provided where required to resist overturning. Isolator housings and restraints shall not be constructed of cast iron or other materials with limited ductility. (See additional design force requirements in Table 6.3.2.) A viscoelastic pad or similar material of appropriate thickness shall be used between the bumper and equipment item to limit the impact load.

**6.3.15 ALTERNATIVE SEISMIC QUALIFICATION METHODS:** As an alternative to the analysis methods implicit in the design methodology described above, equipment testing is an acceptable method to determine seismic capacity. Thus, adaptation of a nationally recognized standard, such as Ref. 6-16, is acceptable so long as the equipment seismic capacity equals or exceeds the demand expressed in Sec. 6.1.3 and 6.1.4.

**6.3.16 ELEVATOR DESIGN REQUIREMENTS:** Elevators shall meet the force and displacement provisions of Sec. 6.3.2 unless exempted by either Sec. 1.2 or Sec. 6.1. Elevators designed in accordance with the seismic provisions of Ref. 6-1 shall be deemed to meet the seismic force requirements of this section, except they also shall meet the additional requirements provided in Sec. 6.3.16.1 through 6.3.16.4..

**6.3.16.1 Elevators and Hoistway Structural System:** Elevators and hoistway structural systems shall be designed to meet the force and displacement provisions of Sec. 6.3.2.

**6.3.16.2 Elevator Machinery and Controller Supports and Attachments:** Elevator machinery and controller supports and attachments shall be designed to meet the force and displacement provisions of Sec. 6.3.2.

**6.3.16.3 Seismic Controls:** Seismic switches shall be provided for all elevators addressed by Sec. 6.3.16.1 including those meeting the requirements of the ASME reference, provided they operate with a speed of 150 ft/min (46 m/min) or greater. Seismic switches shall provide an electrical signal indicating that structural motions are of such a magnitude that the operation of elevators may be impaired. Upon activation of the seismic switch, elevator operations shall conform to provisions in Ref. 6-1 except as noted below. The seismic switch shall be located at or above the highest floor serviced by the elevators. The seismic switch shall have two horizontal perpendicular axes of sensitivity. Its trigger level shall be set to 30 percent of the acceleration of gravity

In facilities where the loss of the use of an elevator is a life-safety issue, the elevator may be used after the seismic switch has triggered provided that:

1. The elevator shall operate no faster than the service speed,
2. The elevator shall be operated remotely from top to bottom and back to top to verify that it is operable, and
3. The individual putting the elevator back in service should ride the elevator from top to bottom and back to top to verify acceptable performance.

**6.3.16.4 Retainer Plates:** Retainer plates are required at the top and bottom of the car and counterweight.

## Chapter 7

### FOUNDATION DESIGN REQUIREMENTS

**7.1 GENERAL:** This chapter includes only those foundation requirements that are specifically related to seismic resistant construction. It assumes compliance with all other basic requirements. These requirements include, but are not limited to, requirements for the extent of the foundation investigation, fills to be present or to be placed in the area of the *structure*, slope stability, subsurface drainage, and settlement control. Also included are pile requirements and capacities and bearing and lateral soil pressure recommendations.

**7.2 STRENGTH OF COMPONENTS AND FOUNDATIONS:** The resisting capacities of the foundations, subjected to the prescribed *seismic forces* of Chapters 1, 4 and 5, shall meet the requirements of this chapter.

**7.2.1 Structural Materials:** The *strength* of foundation *components* subjected to *seismic forces* alone or in combination with other prescribed loads and their detailing requirements shall conform to the requirements of Chapter 8, 9, 10, 11, or 12. The *strength* of foundation *components* shall not be less than that required for forces acting without *seismic forces*.

**7.2.2 Soil Capacities:** The capacity of the foundation soil in bearing or the capacity of the soil interface between pile, pier, or caisson and the soil shall be sufficient to support the *structure* with all prescribed loads, without *seismic forces*, taking due account of the settlement that the *structure* can withstand. For the load combination including earthquake as specified in Sec. 5.2.7, the soil capacities must be sufficient to resist loads at acceptable strains considering both the short duration of loading and the dynamic properties of the soil.

**7.3 SEISMIC DESIGN CATEGORIES A AND B:** Any construction meeting the requirements of Sec. 7.1 and 7.2 is permitted to be used for *structures* assigned to *Seismic Design Category A* or *B*.

**7.4 SEISMIC DESIGN CATEGORY C:** Foundations for *structures* assigned to *Seismic Design Category C* shall conform to all of the requirements for *Seismic Design Categories A* and *B* and to the additional requirements of this section.

**7.4.1 Investigation:** The authority having jurisdiction may require the submission of a written report that shall include, in addition to the requirements of Sec. 7.1 and the evaluations required in Sec. 7.2.2, the results of an investigation to determine the potential hazards due to slope instability, liquefaction, and surface rupture due to faulting or lateral spreading, all as a result of earthquake motions.

**7.4.2 Pole-Type Structures:** Construction employing posts or poles as columns embedded in earth or embedded in concrete footings in the earth are permitted to be used to resist both axial and lateral loads. The depth of embedment required for posts or poles to resist *seismic forces* shall be determined by means of the design criteria established in the foundation investigation report.

**7.4.3 Foundation Ties:** Individual pile caps, drilled piers, or caissons shall be interconnected by ties. All ties shall be capable of carrying, in tension or compression, a force equal to the product of the larger pile cap or column load times  $S_{DS}$  divided by 4 unless it can be demonstrated that equivalent restraint can be provided by *reinforced concrete* beams within slabs on grade or *reinforced concrete* slabs on grade or confinement by competent rock, hard cohesive soils, very dense granular soils, or other approved means.

**7.4.4 Special Pile Requirements:** The following special requirements for concrete piles, concrete filled steel pipe piles, drilled piers, or caissons are in addition to all other requirements in the code administered by the authority having jurisdiction.

All concrete piles and concrete filled pipe piles shall be connected to the pile cap by embedding the pile reinforcement in the pile cap for a distance equal to the development length as specified in Ref. 6-1. The pile cap connection can be made by the use of field-placed dowels anchored in the concrete pile. For deformed bars, the development length is the full development length for compression without reduction in length for excess area. Where special reinforcement at the top of the pile is required, alternative measures for laterally confining concrete and maintaining toughness and ductile-like behavior at the top of the pile will be permitted provided due consideration is given to forcing the hinge to occur in the confined region.

Where a minimum length for reinforcement or the extent of closely spaced confinement reinforcement is specified at the top of the pile, provisions shall be made so that those specified lengths or extents are maintained after pile cut-off.

**7.4.4.1 Uncased Concrete Piles:** A minimum reinforcement ratio of 0.0025 shall be provided for uncased cast-in-place concrete drilled piles, drilled piers, or caissons in the top one-third of the pile length or a minimum length of 10 ft (3 m) below the ground. There shall be a minimum of four bars with closed ties (or equivalent spirals) of a minimum 1/4 in. (6 mm) diameter provided at 16-longitudinal-bar-diameter maximum spacing with a maximum spacing of 4 in. (102 mm) in the top 2 ft (0.6 m) of the pile. Reinforcement detailing requirements shall be in conformance with Sec. 9.6.2.

**7.4.4.2 Metal-Cased Concrete Piles:** Reinforcement requirements are the same as for uncased concrete piles.

**Exception:** Spiral welded metal-casing of a thickness not less than No. 14 gauge can be considered as providing concrete confinement equivalent to the closed ties or equivalent spirals required in an uncased concrete pile, provided that the metal casing is adequately protected against possible deleterious action due to soil constituents, changing water levels, or other factors indicated by boring records of site conditions.

**7.4.4.3 Concrete-Filled Pipe:** Minimum reinforcement 0.01 times the cross-sectional area of the pile concrete shall be provided in the top of the pile with a length equal to two times the required cap embedment anchorage into the pile cap.

**7.4.4.4 Precast Concrete Piles:** Longitudinal reinforcement shall be provided for precast concrete piles with a minimum steel ratio of 0.01. Ties or equivalent spirals shall be provided at a maximum 16-bar-diameter spacing with a maximum spacing of 4 in. (102 mm) in the top 2 ft (0.6 m). Reinforcement shall be full length.



**7.4.4.5 Precast-Prestressed Piles:** The upper 2 ft (0.6 m) of the pile shall have No. 3 ties minimum at not over 4-in. (102 mm) spacing or equivalent spirals. The pile cap connection is permitted to be by means of dowels as required in Sec. 7.4.4. Pile cap connection is permitted to be by means of developing pile reinforcing strand if a ductile connection is provided.

**7.5 SEISMIC DESIGN CATEGORIES D, E, AND F:** Foundations for *structures* assigned to *Seismic Design Categories D, E, and F* shall conform to all of the requirements for *Seismic Design Category C* construction and to the additional requirements of this section.

**7.5.1 Investigation:** The *owner* shall submit to the authority having jurisdiction a written report that includes an evaluation of potential site hazards such as slope instability, liquefaction, and surface rupture due to faulting or lateral spreading and the determination of lateral pressures on *basement* and retaining *walls* due to earthquake motions.

**7.5.2 Foundation Ties:** Individual spread footings founded on soil defined in Sec. 4.1.2 as *Site Class E* or *F* shall be interconnected by ties. Ties shall conform to Sec. 7.4.3.

**7.5.3 Liquefaction Potential and Soil Strength Loss:** The geotechnical report shall assess potential consequences of any liquefaction and soil *strength* loss, including estimation of differential settlement, lateral movement or reduction in foundation soil-bearing capacity, and shall discuss mitigation measures. Such measures shall be given consideration in the design of the *structure* and can include, but are not limited to, ground stabilization, selection of appropriate foundation type and depths, selection of appropriate structural systems to accommodate anticipated displacements, or any combination of these measures.

The potential for liquefaction and soil *strength* loss shall be evaluated for site peak ground accelerations, magnitudes, and source characteristics consistent with the *design earthquake* ground motions. Peak ground acceleration is permitted to be determined based on a site-specific study taking into account soil amplification effects or, in the absence of such a study, peak ground accelerations shall be assumed equal to  $S_{DS}/2.5$ .

**7.5.4 Special Pile Requirements:** Piling shall be designed and constructed to withstand maximum imposed curvatures from earthquake ground motions and *structure* response. Curvatures shall include free-field soil strains (without the *structure*) modified for soil-pile-*structure* interaction coupled with pile deformations induced by lateral pile resistance to *structure seismic forces*. Concrete piles in *Site Class E* or *F* shall be designed and detailed in accordance with Sec. 9.3.3.3 within seven pile diameters of the pile cap and the interfaces of soft to medium stiff clay or liquefiable strata.

**7.5.4.1 Uncased Concrete Piles:** A minimum reinforcement ratio of 0.005 shall be provided for uncased cast-in-place concrete piles, drilled piers, or caissons in the top one-half of the pile length or a minimum length of 10 ft (3 m) below ground. There shall be a minimum of four bars with closed ties or equivalent spirals provided at 8-longitudinal-bar-diameter maximum spacing with a maximum spacing of 3 in. (76 mm) in the top 4 ft (1.2 m) of the pile. Ties shall be a minimum of No. 3 bars for up to 20-in.-diameter (500 mm) piles and No. 4 bars for piles of larger diameter.

**7.5.4.2 Metal-Cased Concrete Piles:** Reinforcement requirements are the same as for uncased concrete piles.

**Exception:** Spiral welded metal-casing of a thickness not less than No. 14 gauge can be considered as providing concrete confinement equivalent to the closed ties or equivalent spirals required in an uncased concrete pile, provided that the metal casing is adequately protected against possible deleterious action due to soil constituents, changing water levels, or other factors indicated by boring records of site conditions.

**7.5.4.3 Precast Concrete Piles:** Ties in precast concrete piles shall conform to the requirements of Chapter 9 for at least the top half of the pile.

**7.5.4.4 Precast-Prestressed Piles:** For the body of fully embedded foundation piling subjected to vertical loads only, or where the design bending moment does not exceed  $0.20M_{nb}$  (where  $M_{nb}$  is the unfactored ultimate moment capacity at balanced strain conditions as defined in Ref. 6-1, Sec. 10.3.2), spiral reinforcing shall be provided such that  $\rho_s \geq 0.006$ . Pile cap connection shall not be made by developing exposed strand.

**7.5.4.5 Steel Piles:** The connection between the pile cap and steel piles or unfilled steel pipe piles shall be designed for a tensile force equal to 10 percent of the pile compression capacity.

## Chapter 8

### STEEL STRUCTURE DESIGN REQUIREMENTS

**8.1 REFERENCE DOCUMENTS:** The design, construction, and quality of steel components that resist *seismic forces* shall conform to the requirements of the references listed in this section except as modified by the requirements of this chapter.

- Ref. 8-1      *Load and Resistance Factor Design Specification for Structural Steel Buildings (LRFD)*, American Institute of Steel Construction (AISC), December 1993
- Ref. 8-2      *Allowable Stress Design and Plastic Design Specification for Structural Steel Buildings (ASD)*, American Institute of Steel Construction, June 1, 1989
- Ref. 8-3      *Seismic Provisions for Structural Steel Buildings*, American Institute of Steel Construction, 1997, Part I
- Ref. 8-4      *Specification for the Design of Cold-Formed Steel Structural Members*, American Iron and Steel Institute (AISI), 1996
- Ref. 8-5      *Specification for the Design of Cold-formed Stainless Steel Structural Members*, ANSI/ASCE 8-90, American Society of Civil Engineers
- Ref. 8-6      *Standard Specification, Load Tables and Weight Tables for Steel Joists and Joist Girders*, Steel Joist Institute, 1994 Edition
- Ref. 8-7      *Structural Applications for Steel Cables for Buildings*, ASCE 19, 1995 Edition

**8.2 SEISMIC REQUIREMENTS FOR STEEL STRUCTURES:** The design of steel *structures* to resist *seismic forces* shall be in accordance with Section 8.3 or 8.4 for the appropriate *Seismic Design Category*.

**8.3 SEISMIC DESIGN CATEGORIES A, B and C:** Steel *structures* assigned to *Seismic Design Categories* A, B and C, shall be of any construction permitted by the references in Sec. 8.1. An *R* factor as set forth in Table 5.2.2 for the appropriate steel system is permitted when the *structure* is designed and detailed in accordance with the requirements of Ref. 8-3, Part I, or Sec. 8.6, for light framed cold-formed steel wall systems. Systems not detailed in accordance with the above shall use the *R* factor in Table 5.2.2 designated for “steel systems not detailed for seismic”.

**8.4 SEISMIC DESIGN CATEGORIES D, E, and F:** Steel *structures* assigned to *Seismic Design Categories* D, E, and F shall be designed and detailed in accordance with Ref. 8-3, Part I, or Sec. 8.6 for light framed cold-formed steel wall systems.

**8.5 COLD-FORMED STEEL SEISMIC REQUIREMENTS:** The design of cold-formed carbon or low-alloy steel members to resist seismic loads shall be in accordance with the requirements of Ref. 8-4 and the design of cold-formed stainless steel structural I to resist seismic loads shall be in

accordance with the requirements of Ref. 8-5, except as modified by this section. The reference to section and paragraph numbers are to those of the particular specification modified.

**8.5.1 Modifications to Ref. 8-4:** Revise Sec. A5.1.3 of Ref. 8-4 as follows:

"**A4.4 Wind or Earthquake Loads** Where load combinations specified by the applicable code include wind loads, the resulting forces are permitted to be multiplied by 0.75. Seismic load combinations shall be as determined by these provisions."

**8.5.2 Modifications to Ref. 8-5:** Modify Sec. 1.5.2 of Ref. 8-5 by substituting a load factor of 1.0 in place of 1.5 for nominal earthquake load.

**8.6 LIGHT-FRAMED WALLS:** When required by the requirements in Sec. 8.3 or 8.4, cold-formed steel stud *walls* designed in accordance with Ref. 8-4 and 8-5 shall also comply with the requirements of this section.

**8.6.1 Boundary Members:** All boundary members, chords, and collectors shall be designed to transmit the specified induced axial forces .

**8.6.2 Connections:** Connections for diagonal bracing members, top chord splices, boundary members, and collectors shall have a *design strength* equal to or greater than the *nominal tensile strength* of the members being connected or  $\phi$  times the design *seismic force*. The pull-out resistance of screws shall not be used to resist *seismic forces*.

**8.6.3 Braced Bay Members:** In stud systems where the lateral forces are resisted by braced frames, the vertical and diagonal members in braced bays shall be anchored such that the bottom tracks are not required to resist uplift forces by bending of the track or track web. Both flanges of studs shall be braced to prevent lateral torsional buckling. In vertical *diaphragm* systems, the vertical boundary members shall be anchored so the bottom track is not required to resist uplift forces by bending of the track web.

**8.6.4 Diagonal Braces:** Provision shall be made for pretensioning or other methods of installation of tension-only bracing to guard against loose diagonal straps.

**8.6.5 Shear Walls:** Nominal shear values for *wall* sheathing materials are given in Table 8.6. Design shear values shall be determined by multiplying the nominal values therein by a  $\phi$  factor of 0.55. In *structures* over one *story* in height, the assemblies in Table 8.6 shall not be used to resist horizontal loads contributed by forces imposed by masonry or concrete construction.

Panel thicknesses shown in Table 8.6 shall be considered to be minimums. No panels less than 24 inches wide shall be used. Plywood or oriented strand board structural panels shall be of a type that is manufactured using exterior glue. Framing members, blocking or strapping shall be provided at the edges of all sheets. Fasteners along the edges in *shear panels* shall be placed not less than 3/8 inches (9.5 mm) in from panel edges. Screws shall be of sufficient length to assure penetration into the steel stud by at least two full diameter threads.

The height to length ratio of *wall* systems listed in Table 8.6 shall not exceed 2:1.

Perimeter members at openings shall be provided and shall be detailed to distribute the shearing stresses. Wood sheathing shall not be used to splice these members.

Wall studs and track shall have a minimum uncoated base thickness of not less than 0.033 inches (0.84 mm) and shall not have an uncoated base metal thickness greater than 0.048 inches (1.22 mm). Panel end studs and their uplift anchorage shall have the *design strength* to resist the forces determined by the seismic loads determined by Eq. 2.2.6-3 and Eq. 2.2.6-4.

**TABLE 8.6 Nominal Shear Values for Seismic Forces for Shear Walls Framed with Cold-Formed Steel Studs (in pounds per foot)<sup>a, b</sup>**

Assembly Description	Fastener Spacing at Panel Edges <sup>c</sup> (inches)				Framing Spacing (inches o.c.)
	6	4	3	2	
15/32 rated Structural I sheathing (4-ply) plywood one side <sup>d</sup>	780	990	1465	1625	24
7/16 in. oriented strand board one side <sup>d</sup>	700	915	1275	1700	24

NOTE: For fastener and framing spacing, multiply inches by 25.4 to obtain metric mm.

<sup>a</sup> Nominal shear values shall be multiplied by the appropriate strength reduction factor  $\phi$  to determine *design strength* as set forth in Sec. 8.6.5.

<sup>b</sup> Studs shall be a minimum 1-5/8 in. by 3-1/2 in. with a 3/8-in. return lip. Track shall be a minimum 1-1/4 in. by 3-1/2 in. Both studs and track shall have a minimum uncoated base metal thickness of 0.033 inches and shall be ASTM A446 Grade A (or ASTM A653 SQ Grade 33 [new designation]). Framing screws shall be No. 8 x 5/8 in. wafer head self-drilling. Plywood and OSB screws shall be a minimum No. 8 x 1 in. bugle head. Where horizontal straps are used to provide blocking they shall be a minimum 1-1/2 in. wide and of the same material and thickness as the stud and track.

<sup>c</sup> Screws in the field of the panel shall be installed 12 inches o.c. unless otherwise shown.

<sup>d</sup> Both flanges of the studs shall be braced in accordance with Sec. 8.6.3.

**8.7 SEISMIC REQUIREMENTS FOR STEEL DECK DIAPHRAGMS:** Steel deck *diaphragms* shall be made from materials conforming to the requirements of Ref. 8-4 or 8-5. *Nominal strengths* shall be determined in accordance with approved analytical procedures or with test procedures prepared by a *registered design professional* experienced in testing of cold-formed steel assemblies and approved by the authority having jurisdiction. *Design strengths* shall be determined by multiplying the *nominal strength* by a resistance factor,  $\phi$ , equal to 0.60 (for mechanically connected *diaphragms*) and equal to 0.50 (for welded *diaphragms*). The steel deck installation for the *structure*, including fasteners, shall comply with the test assembly arrangement. Quality standards established for the nominal strength test shall be the minimum standards required for the steel deck installation, including fasteners.

**8.8 STEEL CABLES:** The *design strength* of steel cables shall be determined by the requirements of Ref. 8-7 except as modified by these *Provisions*. Sec. 5d of Ref. 8-7 shall be modified by substituting  $1.5(T_4)$  where  $T_4$  is the net tension in cable due to *dead load*, prestress, *live load*, and seismic load. A load factor of 1.1 shall be applied to the prestress force to be added to the load combination of Sec. 3.1.2 of Ref. 8-7.

## Chapter 9

### CONCRETE STRUCTURE DESIGN REQUIREMENTS

**9.1 REFERENCE DOCUMENTS:** The quality and testing of concrete and steel materials and the design and construction of concrete *components* that resist *seismic forces* shall conform to the requirements of the reference listed in this section except as modified by the requirements of this chapter.

Ref. 9-1      *Building Code Requirements for Structural Concrete*, American Concrete Institute, ACI 318-95, excluding Appendix A

#### 9.1.1 Modifications to Ref. 9-1:

**9.1.1.1:** Replace Sec. 9.2.3 with Sec. 5.2.7 of these *Provisions*. Add the following:

“**9.3.1.2** For load combinations that include earthquake loads, the *design strength* shall be computed using the *strength* reduction factors,  $\phi$ , listed in Appendix C.”

**9.1.1.2:** Insert the following notations in Sec. 21.0:

	=	the angle between the diagonal reinforcement and the longitudinal axis.
$A_b$	=	the area, in. <sup>2</sup> (mm <sup>2</sup> ) of the shank of the bolt or stud.
$A_{vd}$	=	total area of reinforcement in each group of diagonal bars.
$c'_u$	=	neutral axis depth at $P'_u$ and $M'_n$ .
$\ell_p$	=	height of the plastic hinge above critical section and which shall be established on the basis of substantiated test data or may be alternately taken at $0.5 w$ .
$P'_u$	=	$1.2D + 0.5L + E$ .
$h$	=	Overall dimension of member in the direction of action considered.
$S_{e\text{ Connection}}$	=	moment, shear, or axial force at connection cross section other than the nonlinear action location corresponding to probable <i>strength</i> at the nonlinear action location, taking <i>gravity load</i> effects into consideration per 21.2.7.3.
$S_{n\text{ Connection}}$	=	<i>nominal strength</i> of connection cross section in flexural, shear, or axial action per 21.2.7.3.
$E$	=	elastic <i>design displacement</i> at the top of the wall using gross section properties and code-specified <i>seismic forces</i> .

$\Delta_i$	=	inelastic deflection at top of wall = $\Delta_t - \Delta_y$ .
$\Delta_m$	=	$C_d \Delta_s$ .
$\Delta_s$	=	<i>design level response displacement</i> , which is the total drift or total story drift that occurs when the <i>structure</i> is subjected to the design seismic forces.
$\Delta_t$	=	total deflection at the top of the wall equal to $C_d$ times the elastic <i>design displacement</i> using cracked section properties or may be taken as $(I_g/I_{eff})C_d \Delta_E$ . $I_g$ is the gross moment of inertia of the wall and $I_{eff}$ is the effective moment of inertia of the wall. $I_{eff}$ may be taken as $0.5I_g$ .
$\Delta_y$	=	<i>displacement</i> at the top of the wall corresponding to yielding of the tension reinforcement at critical section or may be taken as $(M'_n/M_E)\Delta_E$ where $M_E$ equals moment at critical section when top of wall is displaced $\Delta_E$ . $M'_n$ is nominal flexural <i>strength</i> of critical section at $P'_u$ .
$\phi_y$	=	yield curvature which may be estimated as $0.003/\ell_w$ .
	=	dynamic amplification factor from 21.2.7.3 and 21.2.7.4.

**9.1.1.3:** Insert the following definitions in Sec. 21.1:

**"Connection** -- An *element* that joins two precast members or a precast member and a cast-in-place member.

**"Dry Connection** -- Connection used between precast members which does not qualify as a wet connection.

**"Joint** -- The geometric volume common to intersecting members.

**"Nonlinear Action Location** -- Center of the region of yielding in flexure, shear, or axial action.

**"Nonlinear Action Region** -- The member length over which nonlinear action takes place. It shall be taken as extending a distance of no less than  $h/2$  on either side of the nonlinear action location.

**"Strong Connection** -- A connection that remains elastic while the designated nonlinear action regions undergo inelastic response under the design basis ground motion.

**"Wet Connection** -- A connection that uses any of the splicing methods, per 21.2.6.1 or 21.3.2.3, to connect precast members and uses cast-in-place concrete or grout to fill the splicing closure."

**9.1.1.4:** Replace Sec. 21.2.1.3 and 21.2.1.4 with the requirements of Sec. 9.4 through 9.7.

**9.1.1.5:** Insert the following new Sec. 21.2.1.6 and 21.2.1.7:

"**21.2.1.6** A precast *seismic-force-resisting system* shall be permitted provided it satisfies either of the following criteria:

- "1. It emulates the behavior of monolithic *reinforced concrete* construction and satisfies 21.2.2.5, or
- "2. It relies on the unique properties of a structural system composed of interconnected precast *elements* and it is demonstrated by experimental evidence and analysis to safely sustain the seismic loading requirements of a comparable monolithic *reinforced concrete structure* satisfying Chapter 21. Substantiating experimental evidence of acceptable performance of those *elements* required to sustain inelastic *deformations* shall be based upon cyclic inelastic testing of specimens representing those *elements*.

"**21.2.1.7** In *structures* having precast *gravity load* carrying systems, the *seismic-force-resisting system* shall be one of the systems listed in Table 5.2.2 of the 1997 *NEHRP Recommended Provisions* and shall be well distributed using one of the following methods:

- "1. The *seismic-force-resisting system* shall be spaced such that the span of the *diaphragm* or *diaphragm* segment between *seismic-force-resisting systems* shall be no more than three times the width of the *diaphragm* or *diaphragm* segment. Where the *seismic-force-resisting system* consists of moment resisting frames, at least  $(N_b/4) + 1$  of the bays (rounded up to the nearest integer) along any frame line at any *story* shall be part of the *seismic-force-resisting system* where  $N_b$  is the total number of bays along that line at that *story*. This requirement applies to only the lower two thirds of the stories of *buildings* three stories or taller.
- "2. All beam-to-column connections that are not part of the *seismic-force-resisting system* shall be designed in accordance with the following:

**Connection Design Force.** The connection shall be designed to develop *strength*  $M$ .  $M$  is the moment developed at the connection when the frame is displaced by  $\Delta_m$  assuming fixity at the connection and a beam flexural stiffness of no less than one half of the gross section stiffness.  $M$  shall be sustained through a *deformation* of  $\Delta_m$ .

**Connection Characteristics.** The connection shall be permitted to resist moment in one direction only, positive or negative. The connection at the opposite end of the member shall resist moment with the same positive or negative sign. The connection shall be permitted to have zero flexural stiffness up to a frame *displacement* of  $\Delta_m$ .

In addition, complete calculations for the *deformation* compatibility of the *gravity load* carrying system shall be made in accordance with 5.2.2.4.3 of the 1997 *NEHRP Recommended Provisions* using cracked section stiffness in the *seismic-force-resisting system* and the *diaphragm*.

Where gravity columns are not provided with lateral support on all sides, a positive connection shall be provided along each unsupported direction parallel to



a principal plan axis of the *structure*. The connection shall be designed for a horizontal force equal to 4 percent of the axial load *strength*,  $P_o$ , of the column.

The bearing length shall be calculated to include end rotation, sliding, and other movements of precast ends at supports due to earthquake motions in addition to other movements and shall be at least 2 inches more than that required for bearing *strength*.”

**9.1.1.6:** Insert the following new Sec. 21.2.2.5, 21.2.2.6 and 21.2.2.7:

**"21.2.2.5** Precast structural systems using frames and emulating the behavior of monolithic *reinforced concrete* construction shall satisfy either 21.2.2.6 or 21.2.2.7.

**"21.2.2.6** Precast structural systems utilizing wet connections shall comply with all the applicable requirements of monolithic concrete construction for resisting *seismic forces*.

**"21.2.2.7** Precast structural systems not meeting 21.2.2.6 shall utilize strong connections resulting in nonlinear response away from connections. Design shall satisfy the requirements of 21.2.7 in addition to all the applicable requirements of monolithic concrete construction for resisting *seismic forces*, except that provisions of 21.3.1.2 shall apply to the segments between nonlinear action locations.

**9.1.1.7:** Change Sec. 21.2.5.1 as follows and insert the following new Sec. 21.2.5.2 and 21.2.5.3.

**"21.2.5.1** Except as permitted in 21.2.5.2 and 21.2.5.3, reinforcement resisting earthquake-induced flexural and axial forces in frame members and in *wall boundary elements* shall comply with ASTM A 706. ASTM A 615 Grades 40 and 60 reinforcement shall be permitted in these members if (a) the actual yield *strength* based on mill tests does not exceed the specified yield *strength* by more than 18,000 psi (retests shall not exceed this value by more than an additional 3000 psi), and (b) the ratio of the actual ultimate tensile *strength* to the actual tensile yield *strength* is not less than 1.25.

**"21.2.5.2** Prestressing tendons shall be permitted in flexural members of frames provided the average prestress,  $f_{pc}$ , calculated for an area equal to the member's shortest cross-sectional dimension multiplied by the perpendicular dimension shall not exceed the lesser of 700 psi or  $f_c'/6$  at locations of nonlinear action where prestressing tendons are used in members of frames.

**"21.2.5.3** For members in which prestressing tendons are used together with reinforcement to resist earthquake-induced forces, prestressing tendons shall not provide more than one quarter of the *strength* for both positive moments and negative moments at the *joint* face and shall extend through exterior *joints* and be anchored at the exterior face of the *joint* or beyond. Anchorages for tendons must be demonstrated to perform satisfactorily for seismic loadings. Anchorage assemblies shall withstand, without failure, a minimum of 50 cycles of loading ranging between 40 and 85 percent of the minimum specified tensile strength of the tendon. Tendons shall extend through exterior *joints* and be anchored at the exterior face or beyond."

**9.1.1.8:** Change Sec. 21.2.6.1 as follows:

“**21.2.6.1** Reinforcement resisting earthquake-induced flexural or axial forces in frame members or in *wall boundary members* is permitted to be spliced using welded splices or mechanical connectors conforming to 12.14.3.3 or 12.14.3.4 provided that: (a) not more than alternate bars in each layer of longitudinal reinforcement are spliced at a section and (b) the center-to-center distance between splices of adjacent bars is 24 inches or more measured along the longitudinal axis of the member.

“**Exception:** Items (a) and (b) need not apply where splices are used outside the following locations (i) *joints* or (ii) where analysis indicates flexural yielding caused by inelastic lateral displacement of the frame.”

**9.1.1.9:** Insert the following new Sec. 21.2.7:

“**21.2.7 Emulation of monolithic construction using strong connections.** Members resisting earthquake-induced forces in precast frames using strong connections shall satisfy the following:

“**21.2.7.1 Location.** Nonlinear action location shall be selected so that there is a strong column/weak beam *deformation* mechanism under seismic effects. The nonlinear action location shall be no closer to the near face of strong connection than  $h/2$ . For column-to-footing connections where nonlinear action may occur at the column *base* to complete the mechanism, the nonlinear action location shall be no closer to the near face of the connection than  $h/2$ .

“**21.2.7.2 Anchorage and splices.** Reinforcement in nonlinear action region shall be fully developed outside both the strong connection region and the nonlinear action region. Noncontinuous anchorage reinforcement of strong connection shall be fully developed between the connection and the beginning of nonlinear action region. Lap splices are prohibited within connections adjacent to a *joint*.

“**21.2.7.3 Design forces.** *Design strength* of strong connections shall be based on:

$$\phi S_{n\text{Connection}} > S_{e\text{Connection}} \quad (21-A)$$

Dynamic amplification factor,  $\gamma$ , shall be taken as 1.0.

“**21.2.7.4 Column-to-column connection.** The *strength* of such connections shall comply with 21.2.7.3 with  $\gamma$  taken as 1.4. Where column-to-column connections occur, the columns shall be provided with transverse reinforcement as specified in 21.4.4.1 through 21.4.4.3 over their full height if the factored axial compressive force in these members, including seismic effects, exceeds  $A_g f'_c / 10$ .

“**Exception:** Where column-to-column connection is located within the middle third of the column clear height, the following shall apply: (a) the *design moment strength*,  $\phi M_n$ , of the connection shall not be less than 0.4 times the maximum  $M_{pr}$  for the column within the *story* height and (b) the *design shear strength*  $\phi V_n$  of the connection shall not be less than that determined per 21.4.5.1.

**“21.2.7.5 Column-face connection.** Any strong connection located outside the middle half of a beam span shall be a wet connection unless a dry connection can be substantiated by approved cyclic test results. Any mechanical connector located within such a column-face strong connection shall develop in tension or compression, as required, at least 40 percent of the specified yield *strength*,  $f_y$ , of the bar.”

**9.1.1.10:** Add the following new Sec. 21.4.5.3:

**"21.4.5.3:** At any section where the *design strength*,  $\phi P_n$ , of the column is less than the sum of the shear  $V_e$  computed in accordance with 21.4.5.1 for all the beams framing into the column above the level under consideration, special transverse reinforcement shall be provided. For beams framing into opposite sides of the column, the moment *components* may be assumed to be of opposite sign. For determination of the *nominal strength*,  $P_n$ , of the column, these moments may be assumed to result from the *deformation* of the frame in any one principal axis."

**9.1.1.11:** Change the reference to Sec. 9.2 in Sec. 21.6.3 to the load combination specified in Sec. 5.2.7 of this document for earthquake forces.

**9.1.1.12:** Replace Sec. 21.6.4.1 with the following:

**“21.6.4 Diaphragms** used to resist prescribed lateral forces shall comply with the following:

- “1. Thickness shall not be less than 2 inches. Topping slabs placed over precast floor or roof *elements* shall not be less than 2-1/2 inches thick.
- “2. Where mechanical connectors are used to transfer forces between the *diaphragm* and the lateral system, the anchorage shall be adequate to develop  $1.4A_s f_y$  where  $A_s$  is the connectors cross sectional area.
- “3. Collector and *boundary elements* of topping slabs placed over precast floor and roof *elements* shall not be less than 3 inches or  $6d_b$  thick where  $d_b$  is the diameter of the largest reinforcing bar in the topping slab.
- “4. Prestressing tendons shall not be used as primary reinforcement in boundaries and *collector elements* of structural *diaphragms*. Precompression from unbonded tendons may be used to resist *diaphragm* forces.”

**9.1.1.13** Replace Sec. 21.6.6 with the following:

**“21.6.6 Design of structural walls for flexural and axial loads:**

**“21.6.6.1** Structural *walls* and portions of structural *walls* subject to combined flexural and axial loads shall be designed in accordance with 10.2 and 10.3 except that 10.3.6 and the nonlinear strain requirements of 10.2.2 do not apply. The *strength*-reduction factor  $\phi$  shall be in accordance with 9.3

**“21.6.6.2** Unless a more detailed analysis is made, the design of flanges for I-, L-, C-, or T-shaped sections shall conform to the following:

- “1. In compression, the effective flange width shall not be assumed to extend further from the face of the web than one-half the distance to an adjacent structural wall web or 15 percent of the total height of the wall above the level considered.
- “2. In tension, the amount of reinforcement used shall be not less than that within the web plus a distance on either side, extending from the face of the web, equal to the smallest of 30 percent of the total height of the wall above the level considered, one-half the distance to an adjacent structural wall web, or the actual projection of the flange.

“**21.6.6.3** Walls and portions of walls with  $P_u > 0.35P_o$  shall not be considered to contribute to the calculated *strength* of the *structure* for resisting earthquake-induced forces. Such walls shall conform to the requirements of 5.2.2.4.3 of the 1997 *NEHRP Recommended Provisions*.

“**21.6.6.4** Structural walls and portions of structural walls shall have boundary zones satisfying the requirements of 21.6.6.5, 21.6.6.6, or 21.6.6.7.

“**21.6.6.5** No boundary zones shall be required if the following conditions exist:

- “1.  $P_u \leq 0.10A_g f'_c$  for geometrically symmetrical wall sections  
 $P_u \leq 0.05A_g f'_c$  for geometrically unsymmetrical wall sections  
and either

“2.  $M_u/V_u \ell_w \leq 1.0$

or

“3.  $V_u \leq 3A_{cv} \sqrt{f'_c}$  and  $M_u/V_u \ell_w \leq 3.0$

“**21.6.6.6** Structural walls and portions of structural walls not satisfying 21.5.6.6.5 shall be provided with boundary zones at each end dimensioned and reinforced in accordance with 21.6.6.9. The horizontal lengths of those boundary zones shall be determined using 21.6.6.7 or 21.6.6.8.

“**21.6.6.7** Unless a more detailed analysis is made in accordance with 21.6.6.8, boundary zone horizontal lengths shall be assumed to vary linearly from  $0.25 \ell_w$  to  $0.15 \ell_w$  for  $P_u$  varying from  $0.35P_o$  to  $0.15P_o$ . The boundary zone horizontal length shall not be taken as less than  $0.15 \ell_w$ .

“**21.6.6.8** Requirements for boundary zone horizontal lengths shall be determined based on compressive strain levels at extreme edges when the wall or portion of wall is subjected to *displacement* levels calculated from Eq. 5.3.7.1 of the 1997 *NEHRP Recommended Provisions* using cracked shear area and moment of inertia properties and considering the response modifications effects of possible nonlinear behavior of the *building*.

Boundary zone detail requirements as defined in 21.6.6.9 shall be provided over those portions of the wall, horizontally and vertically, where compressive strains exceed 0.003. In no instance shall designs permit compressive strains greater than 0.015.

For structural *walls* in which flexural yielding at the *base* of the wall is the governing state, compressive strains at the extreme edges of *walls* may be determined as follows:

“1. The total curvature demand,  $\phi_t$ , shall be determined from Eq. (21-B)

$$\phi_t = \frac{\Delta_i}{\left(h_w - \frac{p}{2}\right)^p} + \phi_y \quad (21-B)$$

“2. If  $\phi_t$  is less than or equal to  $0.003/c'_u$ , boundary zone detailed as defined in 21.6.6.9 are not required. If  $\phi_t$  exceeds  $0.003/c'_u$ , the compressive strains may be assumed to vary linearly over the depth  $c'_u$  and have maximum value equal to the product of  $c'_u$  and  $\phi_t$ .

“**21.6.6.9 Structural wall boundary zone detail requirements.** Boundary zone details shall meet the following:

“1. Dimensional requirements:

“1.1 All portions of the boundary zones shall have a thickness of  $\ell_u/16$  or greater.

“1.2 Boundary zones shall extend vertically a distance equal to the development length of the largest vertical bar within the boundary zone above the elevation where the requirements of 21.6.6.7 or 21.6.6.8 are met.

Extensions below the *base* of the boundary zone shall conform to 21.4.4.6.

**Exception:** The boundary zone reinforcement need not extend above the boundary zone a distance greater than the larger of  $\ell_w$  or  $M_u/4V_u$ .

“1.3 Boundary zones as determined by the requirements of 21.6.6.8 shall have a minimum length of 18 inches at each end of the wall or portion of wall.

“1.4 In I-, L-, C-, or T-shaped sections, the boundary zone at each end shall include the effective flange width in compression and shall extend at least 12 inches into the web.

“2. Confinement reinforcement:

“2.1 All vertical reinforcement within the boundary zone shall be confined by hoops or cross ties producing an area of steel not less than:

$$A_{sh} = \frac{0.09 s_h c'_c f'_c}{f_{yh}} \quad (21-C)$$

“2.2 Hoops and cross ties shall have a vertical spacing not greater than the smaller of 6 inches or 6 diameters of the smallest vertical bar within the boundary zone.

“2.3 The ratio of the length to the width of the hoops shall not exceed 3. All adjacent hoops shall be overlapped.

“2.4 Cross ties or legs of overlapping hoops shall not be spaced further apart than 12 inches along the wall.

“2.5 Alternate vertical bars shall be confined by the corner of a hoop or cross tie.

“3. Horizontal reinforcement:

“3.1 All horizontal reinforcement terminating within a boundary zone shall be anchored in accordance with 21.6.2

“3.2 Horizontal reinforcement shall not be lap spliced within the boundary zone.

“4. Vertical reinforcement:

“4.1 Vertical reinforcement shall be provided to satisfy all tension and compression requirements.

“4.2 Area of reinforcement shall not be less than 0.005 times the area of boundary zone or less than two No. 5 (#16) bars at each edge of boundary zone.

“4.3 Lap splices of vertical reinforcement within the boundary zone shall be confined by hoops or cross ties. Spacing of hoops and cross ties confining lap-spliced reinforcement shall not exceed 4 inches.

**9.1.1.14:** Add a new Sec. 21.6.7 as follows and renumber existing Sec. 21.6.7 through 21.6.9 to 21.6.8 through 21.6.10:

**"21.6.7 Coupling Beams:**

"21.6.7.1: For *coupling beams* with  $l_n/d \geq 4$ , the design shall conform to the requirements of 21.2 and 21.3. It shall be permitted to waive the requirements of 21.3.1.3 and 21.3.1.4 if it can be shown by rational analysis that lateral stability is adequate or if alternative means of maintaining lateral stability is provided.

"21.6.7.2: *Coupling beams* with  $l_n/d < 4$  shall be permitted to be reinforced with two intersecting groups of symmetrical diagonal bars. *Coupling beams* with  $l_n/d < 4$  and with factored shear force  $V_u$  exceeding  $4\sqrt{f_c'} b_w d$  metric equivalent is  $0.332 \sqrt{f_c'} b_w d$  where  $f_c'$  is in MPa and  $b_w$  and  $d$  are in mm) shall be reinforced with two intersecting groups of symmetrical diagonal bars. Each group shall consist of a minimum of four bars assembled in a core each side of which is a minimum of  $b_w/2$ . The *design shear strength*,  $\phi V_n$ , of these *coupling beams* shall be determined by:

$$\phi V_n = 2\phi f_y \sin A_{vd} \leq 10\phi \sqrt{f_c'} b_w d \quad (21-D)$$

where  $\phi = 0.85$ .

The metric equivalent of the expression  $10\phi \sqrt{f_c'} b_w d$ , Eq. 21-D, is as follows:

$$0.83 \phi \sqrt{f_c'} b_w d$$

where  $b_w$  and  $d$  are in mm and  $f_c'$  is in MPa.

**Exception:** The design of *coupling beams* need not comply with the requirements for diagonal reinforcement if it can be shown that failure of the *coupling beams* will not impair the vertical load carrying capacity of the *structure*, the egress from the *structure*, or the integrity of nonstructural *components* and connections or produce other unacceptable effects. The analysis shall take into account the changes of stiffness of the *structure* due to the failure of *coupling beams*. *Design strength* of *coupling beams* assumed to be part of the *seismic-force-resisting system* shall not be reduced below the values otherwise required.

**21.6.7.3:** Each group of diagonally placed bars shall be enclosed in transverse reinforcement conforming to 21.4.4.1 through 21.4.4.3. For the purpose of computing  $A_g$  as per Eq. 10-6 and 21-3, the minimum cover as specified in 7.7 shall be assumed over each group of diagonally placed reinforcing bars.

**21.6.7.4:** Reinforcement parallel and transverse to the longitudinal axis shall be provided and, as a minimum, shall conform to 10.5, 11.8.9, and 11.8.10.

**21.6.7.5:** Contribution of the diagonal reinforcement to *nominal flexural strength* of the *coupling beam* area shall be considered.

**9.1.1.5:** Change Sec. 21.7.1 to read as follows:

“**21.7.1:** Frame members assumed not to contribute to lateral resistance shall be detailed according to 21.7.2 or 21.7.3 depending on the magnitude of moments induced in those members when subjected to the lateral *displacements* of 5.2.2.4.3 of the 1997 *NEHRP Recommended Provisions*. Where effects of lateral *displacements* are not explicitly checked, it shall be permitted to apply the requirements of 21.7.3.”

**9.1.1.16:** Change the title of Sec. 21.8 to read: "Requirements for Intermediate Moment Frames."

**9.2 BOLTS AND HEADED STUD ANCHORS IN CONCRETE:** Bolts and headed stud anchors shall be solidly cast in concrete. The factored loads on embedded anchor bolts and headed stud anchors shall not exceed the *design strengths* determined by Sec. 9.2.2.

**9.2.1 Load Factor Multipliers:** In addition to the load factors in Sec. 5.2.7, a multiplier of 2 shall be used if *special inspection* is not provided or of 1.3 if it is provided. When anchors are embedded in the tension zone of a member, the load factors in Sec. 5.2.7 shall have a multiplier of 3 if *special inspection* is not provided or of 2 if it is provided.

**9.2.2 Strength of Anchors:** *Strength* of anchors cast in concrete shall be taken as the lesser of the *strengths* associated with concrete failure and anchor steel failure. Where feasible, anchor connections, particularly those subject to seismic or other dynamic loads, shall be designed and detailed such that connection failure is initiated by failure of the anchor steel rather than by failure of the surrounding concrete. Reinforcement also shall be permitted to be used for direct transfer of tension and shear loads. Such reinforcement shall be designed with proper consideration of its development and its orientation with respect to the postulated concrete failure planes.

The *strength* of headed bolts and headed studs cast in concrete shall be based on testing in accordance with Sec. 9.2.3 or calculated in accordance with Sec. 9.2.4. The bearing area of headed anchors shall be at least one and one-half times the shank area.

**9.2.3 Strength Based on Tests:** The *strength* of anchors shall be based on not less than 10 representative tests conforming to the proposed materials and anchor size and type, embedment length, and configuration as to attachment plates, loads applied, and concrete edge distances. The *nominal strength* shall be the mean value derived from the tests minus one standard deviation. The *strength* reduction factor applied to the *nominal strength* shall be 0.8 when anchor failure governs in the majority of the tests and 0.65 when concrete failure controls.

**9.2.4 Strength Based on Calculations:** Calculations for *design strength* shall be in accordance with Sec. 9.2.4.1 through 9.2.4.3.

**9.2.4.1 Strength in Tension:** The *design tensile strength* of the individual anchors or adequately connected groups of anchors shall be the minimum of  $P_s$  or  $\phi P_c$  where:

1. *Design tensile strength* governed by steel,  $P_s$ , in pounds (N), is:

$$P_s = 0.9A_b F_u n \quad (9.2.4.1-1)$$

2. *Design tensile strength* governed by concrete failure,  $\phi P_c$  in pounds (N) is as follows:

- a. For individual anchors or groups of anchors with individual anchors spaced at least twice their embedment length apart and spaced not less than one anchor embedment length from a free edge of the concrete:

$$\phi P_c = \phi \lambda \sqrt{f'_c} (2.8A_s) n \quad (9.2.4.1-2)$$

where:

$A_s$  = area (in.<sup>2</sup>) of the assumed failure surface taken as a truncated cone sloping at 45 degrees from the head of the anchor to the concrete surface as shown in Figure 9.2.4.1a;

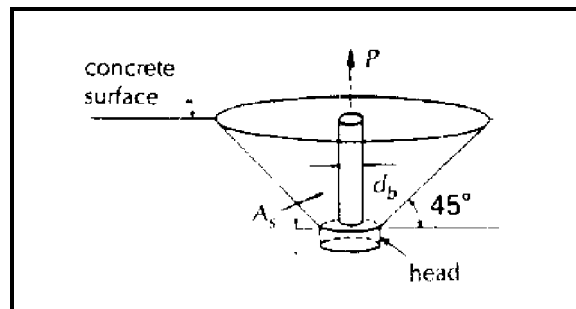

**FIGURE 9.2.4.1a** Shear cone failure for a single headed anchor.

$f'_c$  = concrete *strength* (psi)--6,000 psi (41 MPa) maximum;



- $\phi$  = strength reduction factor of 0.65 except that where special transverse reinforcing is provided to confine the concrete engaged by the anchor and is extended to pass through the failure surface into adjacent concrete,  $\phi$  is permitted to be taken as 0.85;
- $\lambda$  = concrete weight factor--1 for normal weight concrete, 0.85 for sand-light-weight concrete, and 0.75 for lightweight concrete.

The metric equivalent of Eq. 9.2.4.1-2 is:

$$\phi P_c = \frac{\phi \lambda \sqrt{f'_c} (2.8 A_s) n}{12}$$

where  $A_s$  is in  $\text{mm}^2$  and  $f'_c$  is MPa.

Where any anchors are closer to a free edge of the concrete than the anchor embedment length, the *design tensile strength* of those anchors shall be reduced proportionately to the edge distance divided by the embedment length. For multiple edge distances less than the embedment length, use multiple reductions.

- b. For anchor groups where individual anchors are spaced closer together than two embedment lengths:

$$\phi P_c = \phi \lambda \sqrt{f'_c} (2.8 A_p + 4 A_t) \quad (9.2.4.1-3)$$

where:

- $A_p$  = area ( $\text{in.}^2$ ) of an assumed failure surface taken as a truncated pyramid extending from the heads of the outside anchors in the group at 45 degrees to the concrete surface as shown in Figure 9.2.4.1b;
- $A_t$  = area ( $\text{in.}^2$ ) of the flat bottom surface of the truncated pyramid of the assumed concrete failure surface shown in Figure 9.2.4.1b.

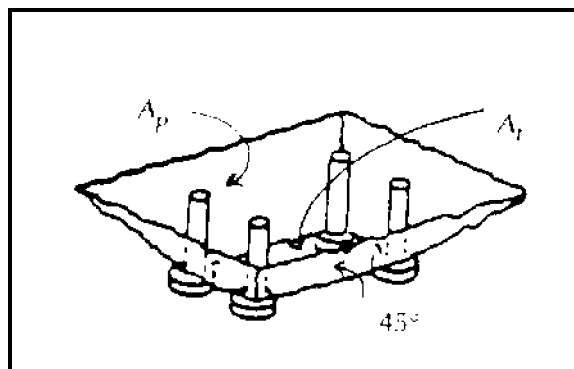

FIGURE 9.2.4.1b Truncated pyramid failure for a group of headed anchors.

The metric equivalent of Eq. 9.2.4.1-3 is:

$$\phi P_c = \frac{\phi \lambda \sqrt{f'_c} (2.8A_p + 4A_t)}{12}$$

where  $A_p$  and  $A_t$  are in  $\text{mm}^2$  and  $f'_c$  is in MPa.

If any anchors are closer to a free edge of the concrete than the anchor embedment length, the *design tensile strength* shall be reduced by using the reduced area  $A_p$  in the equation above.

Anchor groups shall be checked for a critical failure surface passing completely through a concrete member along the 45 degree lines as shown in Figure 9.2.4.1c with  $A_t = 0$  and  $A_p$  based on the area of the sloping failure surface passing completely through the concrete member. The lowest allowable load shall govern.

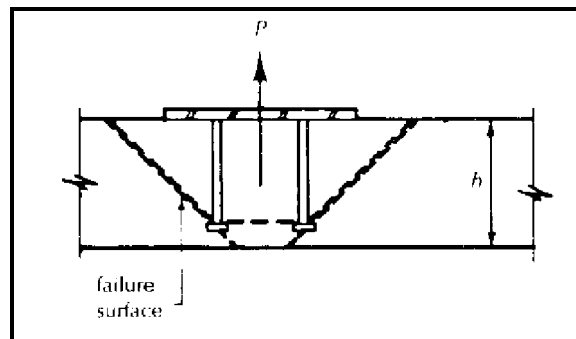

FIGURE 9.2.4.1c Pull-out failure surface for a group of headed anchors in thin section.

**9.2.4.2 Strength in Shear:** The *design shear strength* of anchors shall be the minimum of  $V_s$  or  $\phi V_c$  where the *design shear strength* governed by steel failure is  $V_s$ , in pounds (N), and the *design shear strength* governed by concrete failure is  $\phi V_c$ , in pounds (N). In situations where the embedment and/or concrete edge distances are limited, reinforcement to confine concrete to preclude its premature failure shall be permitted.

- a. Where anchors are loaded toward an edge with edge distance  $d_e$  from the back row of anchors as shown in Figure 9.2.4.2 equal to or greater than 15 anchor diameters and the distance from the front row of anchors to the edge equal to or greater than 6 anchor diameters:

$$V_s = (0.75A_b F_u) n \quad (9.2.4.2-1)$$

$$\phi V_c = (\phi 800 A_b \lambda \sqrt{f'_c}) n \quad (9.2.4.2-2)$$

where:

- $A_b$  = the area, in.<sup>2</sup> (mm<sup>2</sup>) of the shank of the bolt or stud;
- $F_u$  = the specified ultimate tensile *strength* (psi) of the anchor. A307 bolts or A108 studs are permitted to be assumed to have  $F_u$  of 60,000 psi (414 MPa);
- $n$  = the number of anchors;
- $\lambda$  = concrete weight factor--1 for normal weight concrete, 0.85 for sand-lightweight concrete, and 0.75 for lightweight concrete; and
- $f_c$  = concrete *strength* (psi)--6,000 psi (41 MPa) maximum.

The metric equivalent of Eq. 9.2.4.2-2 is:

$$\phi V_c = \frac{(\phi 800 A_b \lambda \sqrt{f'_c}) n}{12}$$

where  $A_b$  is in mm<sup>2</sup> and  $f'_c$  is in MPa.

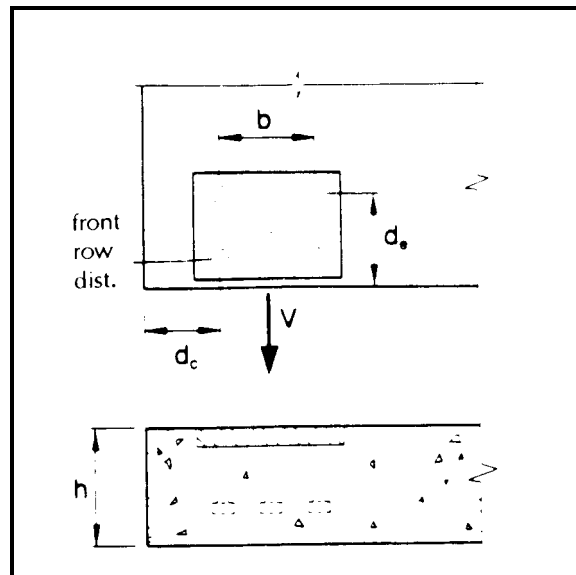

FIGURE 9.2.4.2 Shear on a group of headed anchors.

- b. Where anchors are loaded toward an edge with  $d_e$  less than 15 anchor diameters or the front row closer to the edge than 6 anchor diameters:

$$V_s = (0.75 A_b F_u) n_b \quad (9.2.4.2-3)$$

$$\phi V_c = \phi V'_c C_w C_t C_c \quad (9.2.4.2-4)$$

where:

$A_b$  = the area (in.<sup>2</sup>) of the shank of the bolt or stud.

$F_u$  = the specified ultimate tensile *strength* (psi) of the anchor. A307 bolts or A108 studs are permitted to be assumed to have  $F_u$  of 60,000 psi (414 MPa).

$n_b$  = the number of anchors in the back row.

$\phi V_c'$  = the *design shear strength* of an anchor in the back row:

$$\phi V_c' = \phi 12.5d_e^{1.5}\lambda\sqrt{f_c'} \leq 800A_b\lambda\sqrt{f_c'} \quad (9.2.4.2-5)$$

where  $d_e$  = the distance from the anchor axis to the free edge (in.).

$C_w$  = the adjustment factor for group width:

$$C_w = 1 + \left( \frac{b}{3.5d_e} \right) \leq n_b \quad (9.2.4.2-6)$$

where  $b$  = the center-to-center distance of outermost anchors in the back row (see Figure 9.2.4.2) (in.) and  $d_e$  = the distance from the anchor axis to the free edge (in.).

$C_t$  = the adjustment factor for member thickness:

$$C_t = \frac{h}{1.3d_e} \leq 1.0 \quad (9.2.4.2-7)$$

where  $h$  = the thickness of concrete (in.) and  $d_e$  is as above.

$C_c$  = the adjustment factor for member corner effects:

$$C_c = 0.4 + 0.7 \left( \frac{d_c}{d_e} \right) \leq 1.0 \quad (9.2.4.2-8)$$

where  $d_c$  = the distance, measured perpendicular to the load, from the free edge of the concrete to the nearest anchor in in. (see Figure 9.2.4.2) and  $d_e$  is as above.

The metric equivalent of Eq. 9.2.4.2-5 is:

$$\phi V_c' = \frac{\phi 12.5d_e^{1.5}\lambda\sqrt{f_c'}}{2.39} \leq \frac{\phi 800A_b\lambda\sqrt{f_c'}}{12}$$

where  $d_e$  is in mm,  $A_b$  is in  $\text{mm}^2$  and  $f_c$  is in MPa.

**9.2.4.3 Combined Tension and Shear:** Where tension and shear act simultaneously, all of the following conditions shall be met:

$$\frac{1}{\phi} \left( \frac{V_u}{V_c} \right) \leq 1.0 \quad (9.2.4.3-1a)$$

$$\frac{1}{\phi} \left( \frac{P_u}{P_c} \right) \leq 1.0 \quad (9.2.4.3-1b)$$

$$\frac{1}{\phi} \left[ \left( \frac{P_u}{P_c} \right)^2 + \left( \frac{V_u}{V_c} \right)^2 \right] \leq 1.0 \quad (9.2.4.3-2a)$$

$$\left( \frac{P_u}{P_s} \right)^2 + \left( \frac{V_u}{V_s} \right)^2 \leq 1.0 \quad (9.2.4.3-2b)$$

where:

$P_u$  = required tensile *strength*, in pounds (N), based on factored loads and

$V_u$  = required shear *strength*, in pounds (N), based on factored loads.

**9.3 CLASSIFICATION OF SEISMIC FORCE-RESISTING SYSTEMS:** Reinforced concrete moment frames and structural concrete *shear walls* which resist *seismic forces* shall be classified in accordance with Sec. 9.3.1 and Sec. 9.3.2, respectively.

**9.3.1 Classification of Moment Frames:** Reinforced concrete moment frames which resist *seismic forces* shall be classified in accordance with Sec. 9.3.1.1 through 9.3.1.3.

**9.3.1.1 Ordinary Moment Frames:** Ordinary moment frames are frames conforming to the requirements of Ref. 9-1 exclusive of Chapter 21.

**9.3.1.1.1:** Flexural members of ordinary moment frames forming part of the seismic-force-resisting system shall be designed in accordance with Sec. 7.13.2 of Ref. 9-1 and at least two main flexural reinforcing bars shall be provided continuously top and bottom throughout the beams, through or developed within exterior columns or boundary elements.

**9.3.1.1.2:** Columns of ordinary moment frames having a clear height to maximum plan dimension ratio of 5 or less shall be designed for shear in accordance with Sec. 21.8.3 of Ref. 9-1.

**9.3.1.2 Intermediate Moment Frames:** *Intermediate moment frames* are frames conforming to the requirements of Sec. 21.1, 21.2.1.1, 12.2.1.2, 21.2.2.3, and 21.8 of Ref. 9-1 in addition to those requirements for *ordinary moment frames*.

**9.3.1.3 Special Moment Frames:** *Special moment frames* are frames conforming to the requirements of Sec. 21.1 through 21.5 of Ref. 9-1 in addition to those requirements for *ordinary moment frames*.

**9.3.2 Classification of Shear Walls:** Structural concrete *shear walls* that resist *seismic forces* shall be classified in accordance with Sec. 9.3.2.1 through 9.3.2.4.

**9.3.2.1 Ordinary Plain Concrete Shear Walls:** Ordinary *plain concrete shear walls* are walls conforming to the requirements of Chapter 22 of Ref. 9-1.

**9.3.2.2 Detailed Plain Concrete Shear Walls:** Detailed *plain concrete shear walls* are walls above the *base* conforming to the requirements of Chapter 22 of Ref. 9-1 and containing reinforcement as follows:

Vertical reinforcement of at least  $0.20 \text{ in.}^2$  ( $129 \text{ mm}^2$ ) in cross-sectional area shall be provided continuously from support to support at each corner, at each side of each opening, at the ends of *walls*, and at a maximum spacing of 4 feet (1220 mm) apart horizontally throughout the walls.

Horizontal reinforcement at least  $0.20 \text{ in.}^2$  ( $129 \text{ mm}^2$ ) in cross-sectional area shall be provided:

- a. Continuously at structurally connected roof and floor levels and at the top of *walls*,
- b. At the bottom of load-bearing *walls* or in the top of foundations when doweled to the wall, and
- c. At a maximum spacing of 120 inches (3050 mm).

Reinforcement at the top and bottom of openings, when used in determining the maximum spacing specified in Item c above, shall be continuous in the wall.

*Basement*, foundation, or other *walls* below the *base* shall be reinforced as required by Sec. 22.6.6.5 of Ref. 9-1.

**9.3.2.3 Ordinary Reinforced Concrete Shear Walls:** *Ordinary reinforced concrete shear walls* are walls conforming to the requirements of Ref. 9-1 exclusive of Chapters 21 and 22.

**9.3.2.4 Special Reinforced Concrete Shear Walls:** *Special reinforced concrete shear walls* are walls conforming to the requirements of Sec. 21.1, 21.2, and 21.6 of Ref. 9-1 in addition to the requirements for *ordinary reinforced concrete shear walls*.

**9.4 SEISMIC DESIGN CATEGORY A:** Structures assigned to *Seismic Design Category A* may be of any construction permitted in Ref. 9-1 and these *Provisions*.

**Exception:** *Ordinary moment frames* in *Seismic Design Category A* are not required to comply with Sec. 9.3.1.1.1 and 9.3.1.1.2.

**9.5 SEISMIC DESIGN CATEGORY B:** Structures assigned to *Seismic Design Category B* shall conform to all the requirements for *Seismic Design Category A* and to the additional requirements for *Seismic Design Category B* of this section and in other chapters of these *Provisions*.

**9.5.1 Moment Frames:** All *moment frames* that are part of the *seismic-force-resisting system* of a *building* assigned to *Seismic Design Category B* and founded on *Site Class E* or *F* soils shall be *intermediate moment frames* conforming to Sec. 9.3.1.2 or *special moment frames* conforming to Sec. 9.3.1.3.

**9.6 SEISMIC DESIGN CATEGORY C:** *Buildings* assigned to *Seismic Design Category C* shall conform to all the requirements for *Seismic Design Category B* and to the additional requirements for *Seismic Design Category C* of this section and in other chapters of these *Provisions*.

**9.6.1 Seismic-Force-Resisting Systems:** *Seismic-force-resisting systems* shall conform to Sec. 9.6.1.1 and Sec. 9.6.1.2.

**9.6.1.1 Moment Frames:** All *moment frames* that are part of the *seismic-force-resisting system* shall be *intermediate moment frames* conforming to Sec. 9.3.1.2 or *special moment frames* conforming to Sec. 9.3.1.3.

**9.6.1.2 Shear Walls:** All *shear walls* that are part of the *seismic-force-resisting system* shall be *detailed plain concrete shear walls* conforming to Sec. 9.3.2.2, *ordinary reinforced concrete shear walls* conforming to Sec. 9.3.2.3, or *special reinforced concrete shear walls* conforming to Sec. 9.3.2.4.

**9.6.2 Discontinuous Members:** Columns supporting reactions from discontinuous stiff members such as *walls* shall be designed for special load combinations in Sec. 5.2.7.1 and shall be provided with transverse reinforcement at the spacing  $s_o$  as defined in Sec. 21.8.5.1 of Ref. 9-1 over their full height beneath the level at which the discontinuity occurs. This transverse reinforcement shall be extended above and below the column as required in Sec. 21.4.4.5 of Ref. 9-1.

**9.6.3 Plain Concrete:** Structural *plain concrete* members in *buildings* assigned to *Seismic Design Category C* shall conform to Ref. 9-1 and the additional requirements and limitations of this section.

**9.6.3.1 Walls:** *Walls* used in the *seismic-resisting-force system* shall be *detailed plain concrete shear walls* complying with Sec. 9.3.2.2. Other *walls* that are not serving as *shear walls* shall contain reinforcement as required by Sec. 9.3.2.2.

**9.6.3.2 Footings:** Isolated footings of *plain concrete* supporting pedestals or columns are permitted provided the projection of the footing beyond the face of the supported member does not exceed the footing thickness.

**Exception:** In detached one- and two-family dwellings three stories or less in height, the projection of the footing beyond the face of the supported member shall be permitted to exceed the footing thickness.

*Plain concrete* footings supporting *walls* shall be provided with not less than two continuous longitudinal reinforcing bars. Bars shall not be smaller than No. 4 (#13) and shall have a total area of not less than 0.002 times the gross cross-sectional area of the footing. Continuity of reinforcement shall be provided at corners and intersections.

**Exception:** In detached one- and two-family dwellings three stories or less in height and constructed with stud *bearing walls*, *plain concrete* footings supporting *walls* shall be permitted without longitudinal reinforcement.



**9.6.3.3 Pedestals:** *Plain concrete* pedestals shall not be used to resist lateral *seismic forces*.

**9.7 SEISMIC DESIGN CATEGORIES D, E, OR F:** Structures assigned to *Seismic Design Category D, E or F* shall conform to all of the requirements for *Seismic Design Category C* and to the additional requirements of this section.

**9.7.1 Seismic-Force-Resisting Systems:** *Seismic-force resisting systems* shall conform to Sec. 9.7.1.1 and Sec. 9.7.1.2.

**9.7.1.1 Moment Frames:** All *moment frames* that are part of the *seismic-force-resisting system*, regardless of height, shall be *special moment frames* conforming to Sec. 9.3.1.3.

**9.7.1.2 Shear Walls:** All *shear walls* that are part of the *seismic-force-resisting system* shall be *special reinforced concrete shear walls* conforming to Sec. 9.3.2.4.

**9.7.2 Frame Members Not Proportioned to Resist Forces Induced by Earthquake Motions:** All frame *components* assumed not to contribute to lateral force resistance shall conform to Sec. 2.1.7 of Ref. 9-1 as modified by Sec. 9.1.1.15 of this chapter.

**9.7.3 Plain Concrete:** Structural *plain concrete* members are not permitted in *buildings* assigned to *Seismic Design Category D, E or F*.

**Exceptions:**

1. In detached one- and two-family dwellings three stories or less in height and constructed with stud *bearing walls*, *plain concrete* footings without longitudinal reinforcement supporting *walls* and isolated *plain concrete* footings supporting columns or pedestals are permitted.
2. In all other *buildings*, *plain concrete* footings supporting *walls* are permitted provided the footings are reinforced longitudinally as specified in Sec. 9.6.3.2.
3. In detached one- and two-family dwellings three stories or less in height and constructed with stud *bearing walls*, *plain concrete* foundation or *basement walls* are permitted provided the wall is not less than 7-1/2 in. (190 mm) thick and retains no more than 4 ft (1219 mm) of unbalanced fill.

## Appendix to Chapter 9

### REINFORCED CONCRETE STRUCTURAL SYSTEMS COMPOSED FROM INTERCONNECTED PRECAST ELEMENTS

**PREFACE:** The requirements for *reinforced concrete* structural systems composed of precast *elements* in the body of the *Provisions* are for precast systems emulating monolithic *reinforced concrete* construction. However, one of the principal characteristics of precast systems is that they often are assembled using dry *joints* where connections are made by bolting, welding, post-tensioning, or other similar means. Research conducted to date documents concepts for design using dry *joints* and the behavior of subassemblages composed from interconnected precast *elements* both at and beyond peak *strength* levels for nonlinear reversed cyclic loadings (Applied Technology Council, 1981; Cheok and Lew, 1992; Clough, 1986; Elliott et al., 1987; Hawkins and Englekirk, 1987; Jayashanker and French, 1988; Mast, 1992; Nakaki and Englekirk, 1991; Neille, 1977; New Zealand Society, 1991; Pekau and Hum, 1991; Powell et al., 1993; Priestley, 1991; Priestley and Tao, 1992; Stanton et al., 1986; Stanton et al., 1991).\*\* This appendix is included for information and as a compilation of the current understanding of the performance under seismic loads of structural systems composed from interconnected precast *elements*. It is considered premature to base code requirements on this resource appendix; however, user review, trial designs, and comment on this appendix are encouraged. Please direct such feedback to the BSSC.

#### 9A.1 GENERAL:

**9A.1.1 Scope:** Design and construction of *seismic-force-resisting systems* composed using interconnected precast concrete *elements* shall comply with the requirements of this appendix. The quality and testing of concrete and steel materials and the design and construction of the precast concrete *components* and systems that resist *seismic forces* shall conform to the requirements of the reference document listed in this section except as modified by the requirements of Chapter 9 and this appendix.

#### 9A.1.2 Reference Document:

Ref. 6A-1 *Building Code Requirements for Reinforced Concrete*, American Concrete Institute, ACI 318- 95 excluding Appendices A and C.

**9A.2 GENERAL PRINCIPLES:** A *reinforced concrete* structural system composed from interconnected precast concrete *elements* shall be permitted for the *seismic-force-resisting system*:

---

\*\* See the *Commentary* for this appendix for full reference information.

1. If the force-*deformation* relationships for the connection regions have been validated through physical experiments or the use of analytical models based on the results of physical experiments that closely simulate the *building's* connection regions and
2. If the response of the *building* is analyzed using the force-*deformation* relationships for the connection and *joint* regions in combination with the force-*deformation* relationships for the precast concrete *elements* connected by those regions.

**9A.3 LATERAL FORCE RESISTING STRUCTURAL FRAMING SYSTEMS:**

**9A.3.1:** The basic structural and *seismic-force-resisting systems* and *Seismic Design Category* and *building* height limitations shall be those specified in Table 5.2.2 . The response modification coefficients,  $R$ , and the deflection amplification factors,  $C_d$ , of Table 5.2.2 shall be taken as maximum values for interconnected construction.

**9A.3.2:** The response modification coefficients,  $R$ , and the deflection amplification factors,  $C_d$ , for interconnected construction shall be consistent with the detailing practice for the connections.

**9A.3.3:** Where force-*deformation* relationships for the connections have been determined from analytical modeling and have not been validated through physical experiments,  $R$  and  $C_d$  factors for interconnected construction shall be restricted as shown in Table 9A.3.3.

**TABLE 9A.3.3 Restrictions on  $R$  and  $C_d$**

Restricted Response Modification Coefficient, $R_j$	Restricted Deflection Amplification Factor, $C_{dj}$	Seismic Design Category <sup>a</sup>				Connection Performance Category <sup>b</sup>
		A&B	C	D	E&F	
$R_j \leq R/2$	$C_{dj} \leq C_d/2$	P	P	NP	NP	B
$R/2 \leq R_j \leq R - 1$	$C_d/2 \leq C_{dj} \leq C_d - 1$	P	P	P	P	C

NOTE:  $R = R$  value for monolithic concrete construction in Table 5.2.2 and  $C_d = C_d$  value for monolithic concrete construction in Table 5.2.2.  $R_j$  and  $C_{dj}$  shall be varied in step with  $R$  and  $C_d$  between limits shown. P = permitted and NP = not permitted.

<sup>a</sup> See Tables 4.2.1a and 4.2.1b.

<sup>b</sup> See Sec. 9A.4.3.

**9A.3.4:** Designs shall provide:

1. A continuous load path to the foundation for all *components* for *seismic forces*;
2. Force-*deformation* relationships for the connection and *joint* regions that result in a lateral deflection profile for the *structure* that has deflections increasing continuously with increasing height above the *structure's base* when a horizontal force is applied in any direction at the top of the *structure*; and
3. Integrity of the entire load path at *deformations*  $C_d$  times the elastic *deformation*.

**9A.4 CONNECTION PERFORMANCE REQUIREMENTS:**

**9A.4.1:** Connections that are part of the *seismic-force-resisting system* and are intended to be nonlinear action locations shall have hinging, sliding, or extending characteristics provided by at least one of the following means:

1. Member hinging in flexure due to reinforcement yield in tension and/or compression or in-plane dry *joint* opening rotation constrained by yielding in tension or compression of reinforcement crossing that *joint*.
2. Dry *joint* movement caused by yield in tension, flexure, or shear of steel plates, bars, or shapes crossing that *joint*.
3. In-plane dry *joint* slips caused by shears acting on constrained *deformation* devices such as friction bolted steel assemblies.
4. Other actions for which physical experiments have established the *deformation* response of the connection and the region surrounding the connection or *joint*.

**9A.4.2:** The seismic performance of a given connection depends on the characteristics of all three of the following:

1. Connector -- The device that crosses the interface between the interconnected precast *elements* or the cast-in-place *element*.
2. Anchorage -- The means by which the force in the connector is transferred into the precast or cast-in-place *element*, and
3. Connection Region -- The volume of *element* over which the force from the anchorage flows out to match the uniform stress state for the *element*.

**9A.4.3:** Based on the results of physical experiments or analytical modeling, nonlinear action, connections and their surrounding connection or *joint* regions shall be classified into Connection Seismic Performance Categories A, B, and C as follows:

1. For Connection Performance Category A, there shall be no special requirements.
2. For Connection Performance Category B, connections and their surrounding regions shall exhibit stable inelastic reversed cyclic *deformation* characteristics for the demands placed on them at the  $R$  and  $C_d$  values selected for the *building's seismic-force-resisting system*.
3. For Connection Performance Category C, connections and their surrounding regions shall have stiffness, *strength*, energy absorption, and energy dissipation capacities that ensure a performance for the *building* equivalent to that required for the  $R$  and  $C_d$  values selected for the *building's seismic-force resisting system*.

**9A.4.4:** For *seismic-force-resisting systems* of *Seismic Design Category B*, the nonlinear action connections shall be of Connection Performance Category B or C and the anchorage for any such connector transferring tensile or shear force shall be connected directly by welding or similar means or by adequate lap length to the principal reinforcement of the precast *element* or the cast-in-place *element*.

**9A.4.5:** For *seismic-force-resisting systems* of *Seismic Design Category C, D or E*, the nonlinear action connections shall be of Connection Performance Category C with the anchorage specified in

Sec. 9A.4.4 and with the stressed area at the connection interface for nominal *strength* calculations at least 30 percent of the cross-sectional area of the *element* measured at a distance equal to the section's largest dimension from that interface. The stressed area for principal reinforcement stressed in tension or shear shall be the same as that defined in Sec. 10.6.4 of Ref. 9A-1.

### **9A.5 CONNECTION DESIGN REQUIREMENTS:**

**9A.5.1:** Connections that are nonlinear action locations shall satisfy the following design requirements:

1. The probable *strength*,  $S_{pr}$ , of the connector shall be determined using a  $\phi$  value of unity and a steel stress of at least  $1.25f_y$ .
2. The connector shall be anchored either side of the interface for capacities at least 1.6 times the  $S_{pr}$  value for that connector.

**9A.5.2:** Connectors that are part of the lateral load resisting path and intended to remain elastic while Connection Performance Category B or C connectors undergo nonlinear actions shall have a *strength*,  $S_n$ , at least 1.5 times the load calculated as acting on them when the nonlinear action of the *building's* structural system is fully developed.

**9A.5.3:** Connectors that are nonlinear action locations shall be proportioned so that they provide significant resistance only for the direction in which their capacity is intended to be utilized.

**9A.5.4:** Particular attention shall be given to grouting and welding requirements that shall permit quality control inspection and testing and make allowance for varying tolerances, material properties, and site conditions.

## Chapter 10

### COMPOSITE STEEL AND CONCRETE STRUCTURE DESIGN REQUIREMENTS

**10.1 REFERENCE DOCUMENTS:** The design, construction, and quality of composite steel and concrete components that resist seismic forces shall conform to the relevant requirements of the following references except as modified by the provisions of this chapter.

- Ref. 10-1 *Load and Resistance Factor Design Specification for Structural Steel Buildings (LRFD)*, American Institute of Steel Construction (AISC), 1993
- Ref. 10-2 *Building Code Requirements for Reinforced Concrete*, American Concrete Institute, ACI-318-95, excluding Appendix A
- Ref. 10-3 *Seismic Provisions for Structural Steel Buildings*, American Institute of Steel Construction (AISC), July 1997, Parts I and II
- Ref. 10-4 *Specification for the Design of Cold-Formed Steel Structural Members*, American Iron and Steel Institute (AISI), 1996, excluding ASD provisions

**10.2 REQUIREMENTS:** An  $R$  factor as set forth in Table 5.2.2 for the appropriate composite steel and concrete system is permitted when the *structure* is designed and detailed in accordance with the provisions of Part II of Ref. 10-3.

In *Seismic Design Categories* B and above, the design of such systems shall conform to the requirements of Part II of Ref. 10-3. Composite *structures* are permitted in *Seismic Design Categories* D and above, subject to the limitations in Table 5.2.2, when substantiating evidence is provided to demonstrate that the proposed system will perform as intended by Part II of Ref. 10-3. The substantiating evidence shall be subject to building official approval. Where composite *elements* or connections are required to sustain inelastic deformations, the substantiating evidence shall be based upon cyclic testing.

## Chapter 11

### MASONRY STRUCTURE DESIGN REQUIREMENTS

#### 11.1 GENERAL:

**11.1.1 Scope:** The design and construction of reinforced and plain unreinforced masonry components and systems and the materials used therein shall comply with the requirements of this chapter.

**11.1.2 Reference Documents****8.1.2 REFERENCE DOCUMENTS:** The designation and title of documents cited in this chapter are listed in this section. Compliance with specific provisions of these reference documents is mandatory where required by this chapter.

Ref. 11-1 *Building Code Requirements for Masonry Structures*, ACI 530-95/ASCE 5-95/TMS 402-95

Ref. 11-2 *Specifications for Masonry Structures*, ACI 530.1-95/ASCE 6-95/TMS 602-95

#### 11.1.3 Definitions:

**Anchor:** Metal rod, wire, bolt, or strap that secures masonry to its structural support.

#### **Area:**

**Gross Cross-Sectional Area:** The area delineated by the out-to-out specified dimensions of masonry in the plane under consideration.

**Net Cross-Sectional Area:** The area of masonry units, grout and mortar crossed by the plane under consideration based on out-to-out specified dimensions.

**Bed Joint:** The horizontal layer of mortar on which a masonry unit is laid.

**Backing:** The *wall* surface to which the *veneer* is secured. The backing can be concrete, masonry, steel framing, or wood framing.

**Cleanout:** An opening to the bottom of a grout space of sufficient size and spacing to allow removal of debris.

**Collar Joint:** Vertical longitudinal joint between wythes of masonry or between masonry wythe and back-up construction which is permitted to be filled with mortar or grout.

**Column:** An isolated vertical member whose horizontal dimension measured at right angles to the thickness does not exceed three times its thickness and whose height is at least three times its thickness.

**Composite Masonry:** Multiwythe masonry members acting with composite action.

**Connector:** A mechanical device (including anchors, *wall* ties, and fasteners) for joining two or more pieces, parts, or members.

**Cover:** Distance between surface of reinforcing bar and edge of member.

**Detailed Plain Masonry Shear Wall:** A masonry *shear wall* designed to resist lateral forces neglecting stresses in reinforcement and designed in accordance with Sec. 11.11.2.

**Dimension:**

**Actual Dimension:** The measured dimension of a designated item (e.g., a designated masonry unit or *wall*).

**Nominal Dimension:** The specified dimension plus an allowance for the joints with which the units are to be laid. Nominal dimensions are usually given in whole numbers. Thickness is given first, followed by height and then length.

**Specified Dimension:** The dimension specified for the manufacture or construction of masonry, masonry units, *joints*, or any other component of a *structure*.

**Effective Height:** For braced members, the effective height is the clear height between lateral supports and is used for calculating the slenderness ratio. The effective height for unbraced members is calculated in accordance with engineering mechanics.

**Effective Period:** Fundamental period of the structure based on cracked stiffness.

**Glass Unit Masonry:** Nonload-bearing masonry composed of glass units bonded by mortar.

**Head Joint:** Vertical mortar joint between masonry units within the wythe at the time the masonry units are laid.

**Intermediate Reinforced Masonry Shear Wall:** A masonry *shear wall* designed to resist lateral forces considering stresses in reinforcement and designed in accordance with Sec. 11.11.4.

**Masonry Unit:**

**Hollow Masonry Unit:** A masonry unit whose net cross-sectional area in every plane parallel to the bearing surface is less than 75 percent of the gross cross-sectional area in the same plane.

**Solid Masonry Unit:** A masonry unit whose *net cross-sectional* area in every plane parallel to the bearing surface is 75 percent or more of the gross cross-sectional area in the same plane.

**Ordinary Plain Masonry Shear Wall:** A masonry *shear wall* designed to resist lateral forces neglecting stresses in reinforcement and designed in accordance with Sec. 11.11.1.

**Ordinary Reinforced Masonry Shear Wall:** A masonry *shear wall* designed to resist lateral forces considering stresses in reinforcement and designed in accordance with Sec. 11.11.3.

**Plain Masonry:** Masonry in which the tensile resistance of the masonry is taken into consideration and the effects of stresses in reinforcement are neglected.

**Plastic Hinge:** The zone in a structural member in which the yield moment is anticipated to be exceeded under loading combinations that include earthquake.

**Reinforced Masonry:** Masonry construction in which reinforcement acts in conjunction with the masonry to resist forces.



**Running Bond:** The placement of masonry units such that head *joints* in successive courses are horizontally offset at least one-quarter the unit length.

**Special Reinforced Masonry Shear Wall:** A masonry *shear wall* designed to resist lateral forces considering stresses in reinforcement and designed in accordance with Sec. 11.11.5.

**Specified:** Required by *construction documents*.

**Specified Compressive Strength of Masonry,  $f'_m$ :** Required compressive strength (expressed as force per unit of net cross-sectional area) of the masonry. Whenever the quantity  $f'_m$  is under the radical sign, the square root of numerical value only is intended and the result has units of pounds per square inch (MPa).

**Stack Bond:** Stack bond is other than running bond. Usually, the placement of units is such that the head *joints* in successive courses are aligned vertically.

**Stirrup:** Shear reinforcement in a beam or flexural member.

**Strength:**

**Design Strength:** *Nominal strength* multiplied by a strength reduction factor.

**Nominal Strength:** *Strength* of a member or cross section calculated in accordance with these provisions before application of any strength reduction factors.

**Required Strength:** *Strength* of a member or cross section required to resist factored loads.

**Tie:**

**Lateral Tie:** Loop of reinforcing bar or wire enclosing longitudinal reinforcement.

**Wall Tie:** A connector that joins wythes of masonry *walls* together.

**Veneer:**

**Masonry Veneer:** A masonry wythe which provides the exterior finish of a *wall* system and transfers out-of-plane load directly to a backing, but is not considered to add load resisting capacity to the *wall* system.

**Anchored Veneer:** Masonry *veneer* secured to and supported laterally by the backing through anchors and supported vertically by the foundation or other structural support.

**Adhered Veneer:** Masonry *veneer* secured to and supported by the backing through adhesion.

**Wall:** A vertical element with a horizontal length at least three times its thickness.

**Wall Frame:** A moment resisting frame of masonry beams and masonry columns within a plane, with special reinforcement details and connections that provides resistance to lateral and *gravity loads*.

**Wythe:** A continuous vertical section of a *wall*, one masonry unit in thickness.

**□11.1.4 Notations:**

- $A_b$  = cross-sectional area of an anchor bolt, in.<sup>2</sup> (mm<sup>2</sup>).
- $A_n$  = net cross-sectional area of masonry, in.<sup>2</sup> (mm<sup>2</sup>).
- $A_p$  = projected area on the masonry surface of a right circular cone for anchor bolt allowable shear and tension calculations, in.<sup>2</sup> (mm<sup>2</sup>).
- $A_s$  = cross-sectional area of reinforcement, in.<sup>2</sup> (mm<sup>2</sup>).
- $A_v$  = cross-sectional area of shear reinforcement, in.<sup>2</sup> (mm)<sup>2</sup>
- $a$  = length of compressive stress block, in. (mm).
- $B_a$  = design axial strength of an anchor bolt, lb (N).
- $B_v$  = design shear strength of an anchor bolt, lb (N).
- $b_a$  = factored axial force on an anchor bolt, lb (N).
- $b_v$  = factored shear force on an anchor bolt, lb (N).
- $b_w$  = web width, in. (mm).
- $C_d$  = deflection amplification factor as given in Table 5.2.2
- $c$  = distance from the fiber of maximum compressive strain to the neutral axis, in. (mm).
- $d_b$  = diameter of reinforcement, in. (mm).
- $d_{bb}$  = diameter of the largest beam longitudinal reinforcing bar passing through, or anchored in, the wall frame beam-*column* intersection, in. (mm).
- $d_{bp}$  = diameter of the largest *column* (pier) longitudinal reinforcing bar passing through, or anchored in, the wall frame beam-*column* intersection, in. (mm).
- $d_v$  = length of member in direction of shear force, in. (mm).
- $E_m$  = modulus of elasticity of masonry, psi (MPa).
- $E_s$  = modulus of elasticity of reinforcement, psi (MPa).
- $E_v$  = modulus of rigidity of masonry, psi (MPa).
- $f_g$  = specified compressive *strength* of grout, psi (MPa).
- $f_m'$  = specified compressive *strength* of masonry at the age of 28 days, unless a different age is specified, psi (MPa).
- $f_r$  = modulus of rupture of masonry, psi (MPa).
- $f_y$  = specified yield *strength* of the reinforcement or the anchor bolt as applicable, psi (MPa).
- $h$  = effective height of a *column*, pilaster or *wall*, in. (mm).
- $h_n$  = height of *structure* above the *base* level to level  $n$ , ft. (m).
- $h_b$  = beam depth in the plane of the *wall frame*, in. (mm).
-

- 
- $h_c$  = cross-sectional dimension of grouted core of wall frame member measured center to center of confining reinforcement, in. (mm).
- $h_p$  = pier depth in the plane of the wall frame, in. (mm).
- $I_{cr}$  = moment of inertia of the cracked section, in.<sup>4</sup> (mm<sup>4</sup>).
- $I_{eff}$  = effective moment of inertia, in.<sup>4</sup> (mm<sup>4</sup>).
- $I_n$  = moment of inertia of the net cross-sectional area of a member, in.<sup>4</sup> (mm<sup>4</sup>).
- $L_c$  = length of coupling beam between coupled *shear walls*, in. (mm).
- $l_b$  = effective embedment length of anchor bolt, in. (mm).
- $l_{be}$  = anchor bolt edge distance, in. (mm).
- $l_d$  = development length, in. (mm).
- $l_{dh}$  = equivalent development length for a standard hook, in. (mm).
- $l_{ld}$  = minimum lap splice length, in. (mm).
- $M$  = moment on a masonry section due to unfactored load, in.-lb (N-mm).
- $M_a$  = maximum moment in member due to the applied loading for which deflection is computed, in.-lb (N-mm).
- $M_{cr}$  = cracking moment strength of the masonry, in.-lb (N-mm).
- $M_d$  = design moment strength, in.-lb (N-mm).
- $M_u$  = required flexural strength due to factored loads, in.-lb (N-mm).
- $M_1, M_2$  = nominal moment strength at the ends of the coupling beam, in.-lb (N-mm).
- $N_v$  = force acting normal to shear surface, lb (N).
- $P$  = axial force on a masonry section due to unfactored loads, lb (N).
- $P_n$  = nominal axial load strength, lb (N).
- $P_u$  = required axial strength due to factored loads, lb (N).
- $r$  = radius of gyration, in. (mm).
- $S$  = section modulus based on net cross-sectional area of a *wall*, in.<sup>3</sup> (mm<sup>3</sup>).
- $s$  = spacing of lateral reinforcement in wall frame members, in. (mm).
- $t$  = specified *wall* thickness dimension or least lateral dimension of a column, in. (mm).
- $V$  = shear on a masonry section due to unfactored loads, lb (N).
- $V_m$  = shear strength provided by masonry, lb (N).
- $V_n$  = nominal shear strength, lb (N).
- $V_s$  = shear strength provided by shear reinforcement, lb (N).
-

- $V_u$  = required shear strength due to factored loads, lb (N).  
= design story drift as determined in Sec. 5.3.7.1, in. (mm).  
 $a$  = allowable story drift as specified in Sec. 5.2.8, in. (mm).  
 $\delta_{max}$  = the maximum displacement at level  $x$ , in. (mm).  
= ratio of the area of reinforcement to the net cross-sectional area of masonry in a plane perpendicular to the reinforcement.  
 $b$  = reinforcement ratio producing balanced strain conditions.  
 $\mu_{max}$  = maximum usable compressive strain of masonry, in./in. (mm/mm).  
 $\phi$  = strength reduction factor.

## □ 11.2 CONSTRUCTION REQUIREMENTS:

□ 11.2.1 **General:** Masonry shall be constructed in accordance with the requirements of Ref. 11-2. Materials shall conform to the requirements of the standards referenced in Ref. 11-2.

□ 11.2.2 **Quality Assurance:** Inspection and testing of masonry materials and construction shall comply with the requirements of Chapter 3.

## □ 11.3 GENERAL REQUIREMENTS:

11.3.1 **Scope:** Masonry *structures* and *components* of masonry *structures* shall be designed in accordance with the requirements of reinforced masonry design, plain (unreinforced) masonry design, empirical design or design for architectural components of masonry subject to the limitations of this section. For design of glass-unit masonry and masonry veneer, see Sec. 11.13

□ 11.3.2 **Empirical Masonry Design:** The requirements of Chapter 9 of Ref. 11-1 shall apply to the empirical design of masonry.

### □ 11.3.3 Plain (Unreinforced) Masonry Design:

11.3.3.1: In the design of plain (unreinforced) masonry members, the flexural tensile strength of masonry units, mortar and grout in resisting design loads shall be permitted.

11.3.3.2: In the design of plain masonry members, stresses in reinforcement shall not be considered effective in resisting design loads.

11.3.3.3: Plain masonry members shall be designed to remain uncracked.

□ 11.3.4 **Reinforced Masonry Design:** In the design of reinforced masonry members, stresses in reinforcement shall be considered effective in resisting design loads.

□ 11.3.5 **Seismic Design Category A:** *Structures* assigned to *Seismic Design Category A* shall comply with the requirements of Sec. 11.3.2 (empirical masonry design), Sec. 11.3.3 (plain masonry design), Sec. 11.3.4 (reinforced masonry design).

□ 11.3.6 **Seismic Design Category B:** *Structures* assigned to *Seismic Design Category B* shall conform to all the requirements for *Seismic Design Category A* and the lateral-force-resisting system shall be designed in accordance with Sec. 11.3.3 or Sec. 11.3.4.

□ **11.3.7 Seismic Design Category C:** Structures assigned to *Seismic Design Category C* shall conform to the requirements for *Seismic Design Category B* and to the additional requirements of this section.

**11.3.7.1 Material Requirements:** Structural clay load-bearing wall tile shall not be used as part of the basic structural system.

**11.3.7.2 Masonry Shear Walls:** Masonry *shear walls* shall comply with the requirements for *detailed plain masonry shear walls* (Sec. 11.11.2), *intermediate reinforced masonry shear walls* (Sec. 11.11.4), or *special reinforced masonry shear walls* (Sec. 11.11.5).

**11.3.7.3 Minimum Wall Reinforcement:** Vertical reinforcement of at least  $0.20 \text{ in.}^2$  ( $129 \text{ mm}^2$ ) in cross-sectional area shall be provided continuously from support to support at each corner, at each side of each opening, at the ends of walls and at a maximum spacing of 4 feet (1219 mm) apart horizontally throughout the walls. Horizontal reinforcement not less than  $0.20 \text{ in.}^2$  ( $129 \text{ mm}^2$ ) in cross section shall be provided as follows:

- a. At the bottom and top of wall openings extending not less than 24 in. (610 mm) nor less than 40 bar diameters past the opening,
- b. Continuously at structurally connected roof and floor levels and at the top of walls,
- c. At the bottom of load-bearing walls or in the top of foundations when doveled to the wall,
- d. At maximum spacing of 120 in. (3048 mm) unless uniformly distributed joint reinforcement is provided.

Reinforcement at the top and bottom of openings, when used in determining the maximum spacing specified in Item d above, shall be continuous in the wall.

**11.3.7.4 Stack Bond Construction:** Where stack bond is used, the minimum horizontal reinforcement shall be 0.0007 times the gross cross-sectional area of the wall. This requirement shall be satisfied with uniformly distributed joint reinforcement or with horizontal reinforcement spaced not over 48 in. (1219 mm) and fully embedded in grout or mortar.

**11.3.7.5 Multiple Wythe Walls Not Acting Compositely:** At least one wythe of a cavity *wall* shall be reinforced masonry designed in accordance with Sec. 11.3.4. The other wythe shall be reinforced with a minimum of one W1.7 wire per 4-in. (102 mm) nominal wythe thickness and spaced at intervals not exceeding 16 in. (406 mm). The wythes shall be tied in accordance with Ref. 11-1, Sec. 5.8.3.2.

**11.3.7.6 Walls Separated from the Basic Structural System:** Masonry *walls*, laterally supported perpendicular to their own plane but otherwise structurally isolated on three sides from the basic structural system, shall have minimum horizontal reinforcement of 0.007 times the gross cross-sectional area of the *wall*. This requirement shall be satisfied with uniformly distributed joint reinforcement or with horizontal reinforcement spaced not over 48 in. (1200 mm) and fully embedded in grout or mortar. Architectural components of masonry shall be exempt from this reinforcement requirement.

**11.3.7.7 Connections to Masonry Columns:** Structural members framing into or supported by masonry columns shall be anchored thereto. Anchor bolts located in the tops of columns shall be set entirely within the reinforcing cage composed of column bars and lateral ties. A minimum of two No. 4 (13 mm) lateral ties shall be provided in the top 5 inches (127 mm) of the column.

□ **11.3.8 Seismic Design Category D:** Structures assigned to *Seismic Design Category D* shall conform to all of the requirements for *Seismic Design Category C* and the additional requirements of this section.

**11.3.8.1 Material Requirements:** Neither Type N mortar nor masonry cement shall be used as part of the basic structural system.

**11.3.8.2 Masonry Shear Walls:** Masonry *shear walls* shall comply with the requirements for *special reinforced masonry shear walls* (Sec. 11.11.5)

**11.3.8.3 Minimum Wall Reinforcement:** All walls shall be reinforced with both vertical and horizontal reinforcement. The sum of the areas of horizontal and vertical reinforcement shall be at least 0.002 times the gross cross-sectional area of the wall and the minimum area of reinforcement in each direction shall not be less than 0.0007 times the gross cross-sectional area of the wall. The spacing of reinforcement shall not exceed 48 in. (1219 mm). Except for joint reinforcement, the bar size shall not be less than a No. 3 (10-mm diameter). Reinforcement shall be continuous around wall corners and through intersections, unless the intersecting walls are separated. Only horizontal reinforcement that is continuous in the wall or element shall be included in computing the area of horizontal reinforcement. Reinforcement spliced in accordance with Sec. 11.4.5.6 shall be considered as continuous reinforcement. Architectural components of masonry shall be except from this reinforcement requirement.

**11.3.8.4 Stack Bond Construction:** Where masonry is laid in stack bond, the minimum amount of horizontal reinforcement shall be 0.0015 times the gross cross-sectional area of the wall. If open-end units are used and grouted solid, the minimum amount of horizontal reinforcement shall be 0.0007 times the gross cross-sectional area of the wall. The maximum spacing of horizontal reinforcement shall not exceed 24 in. (610 mm). Architectural components of masonry shall be exempt from these requirements.

**11.3.8.5 Minimum Wall Thickness:** The nominal thickness of masonry bearing *walls* shall not be less than 6 in. (152 mm). Nominal 4-in. (102 mm) thick load-bearing reinforced hollow clay unit masonry *walls* with a maximum unsupported height or length to thickness ratio of 27 are permitted to be used provided the net area unit strength exceeds 8,000 psi (55 MPa), units are laid in *running bond*, bar sizes do not exceed 1/2 in. (13 mm) with not more than two bars or one splice in a cell and joints are not raked.

**11.3.8.6 Minimum Column Reinforcement:** Lateral ties in columns shall be spaced not more than 8 in. (203 mm) on center for the full height of the column. Lateral ties shall be embedded in grout and shall be No. 3 (10 mm) or larger.

**11.3.8.7 Minimum Column Dimension:** The nominal dimensions of a masonry column shall not be less than 12 in. (305 mm).

**11.3.8.8: Separation Joints:** Where concrete abuts structural masonry and the joint between the materials is not designed as a separation joint, the concrete shall be roughened so that the average height of aggregate exposure is 1/8-in. (3 mm) and shall be bonded to the masonry in accordance with these requirements as if it were masonry. Vertical joints not intended to act as separation joints shall be crossed by horizontal reinforcement as required by Sec. 11.3.8.2.

□**11.3.9 Seismic Design Categories E and F:** Structures assigned to *Seismic Design Categories E* and *F* shall conform to the requirements of *Seismic Design Category D* and to the additional requirements and limitations of this section.

**11.3.9.1 Material Requirements:** Construction procedures or admixtures shall be used to minimize shrinkage of grout and to maximize bond between reinforcement, grout, and units.

**11.3.9.2 Masonry Shear Walls:** Masonry shear walls shall comply with the requirements for *special reinforced masonry shear walls* (Sec. 11.11.5).

**11.3.9.3 Stack Bond Construction:** Masonry laid in stack bond shall conform to the following requirements:

**11.3.9.3.1:** For masonry that is not part of the basic structural system, the minimum ratio of horizontal reinforcement shall be 0.0015 and the maximum spacing of horizontal reinforcement shall be 24 in. (610 mm). For masonry that is part of the basic structural system, the minimum ratio of horizontal reinforcement shall be 0.0025 and the maximum spacing of horizontal reinforcement shall be 16 in. (406 mm). For the purpose of calculating this ratio, joint reinforcement shall not be considered.

**11.3.9.3.2:** Reinforced hollow unit construction shall be grouted solid and all *head joints* shall be made solid by the use of open end units.

□**11.3.10 Properties of Materials:**

**11.3.10.1 Steel Reinforcement Modulus of Elasticity:** Unless otherwise determined by test, steel reinforcement modulus of elasticity ( $E_s$ ) shall be taken to be 29,000,000 psi (200,000 MPa).

**11.3.10.2 Masonry Modulus of Elasticity:** The modulus of elasticity of masonry ( $E_m$ ) shall be determined in accordance with Eq. 11.3.10.2 or shall be based on the modulus of elasticity determined by prism test and taken between 0.05 and 0.33 times the masonry prism strength:

$$E_m = 750f'_m \quad (11.3.10.2)$$

where  $E_m$  = modulus of elasticity of masonry (psi) and  $f'_m$  = *specified compressive strength of masonry*, psi. The metric equivalent of Eq. 11.3.10.2 is the same except that  $E_m$  and  $f'_m$  are in MPa.

**11.3.10.3:** The modulus of rigidity of masonry,  $E_v$ , shall be taken equal to 0.4 times the modulus of elasticity of masonry,  $E_m$ .

**11.3.10.4 Masonry Compressive Strength:**

**11.3.10.4.1:** The specified compressive strength of masonry,  $f'_m$ , shall equal or exceed 1,500 psi (10 MPa).

**11.3.10.4.2:** The value of  $f'_m$  used to determine *nominal strength* values in this chapter shall not exceed 4,000 psi (28 MPa) for concrete masonry and shall not exceed 6,000 psi (41 MPa) for clay masonry.

**11.3.10.5 Modulus of Rupture:**

**11.3.10.5.1 Out-of-Plane Bending:** The modulus of rupture,  $f_r$ , for masonry elements subjected to out-of-plane bending shall be taken from Table 11.3.10.5.1.

**TABLE 11.3.10.5.1 Modulus of Rupture for Out-of-Plane Bending ( $f_r$ )**

Masonry type	Mortar types, psi (MPa)			
	Portland cement/lime		Masonry cement and air-entrained Portland cement/lime	
	M or S	N	M or S	N
	Normal to bed <i>joints</i>			
Solid units	80 (0.55)	60 (0.41)	48 (0.33)	30 (0.21)
Hollow units <sup>a</sup>				
UngROUTED	50 (0.34)	38 (0.26)	30 (0.21)	18 (0.12)
Fully grouted	136 (0.94)	116 (0.80)	82 (0.57)	52 (0.36)
Parallel to bed <i>joints</i> in running bond				
Solid units	160 (1.10)	120 (0.83)	96 (0.66)	60 (0.41)
Hollow units				
UngROUTED and partially grouted	100 (0.69)	76 (0.52)	60 (0.41)	38 (0.26)
Fully grouted (running bond masonry)	160 (1.10)	120 (0.83)	96 (0.66)	60 (0.41)
Parallel to bed <i>joints</i> in stack bond:	0	0	0	0

<sup>a</sup> For partially grouted masonry, modulus of rupture values shall be determined on the basis of linear interpolation between hollow units which are fully grouted and hollow units which are ungrouted based on amount (percentage) of grouting.

**11.3.10.5.2 In-Plane Bending:** The modulus of rupture,  $f_r$ , normal to bed *joints* for masonry elements subjected to in-plane forces shall be taken as 250 psi. For grouted *stack bond* masonry, tension parallel to the bed *joints* for in-plane bending shall be assumed to be resisted only by the continuous grout core section.

**11.3.10.6 Reinforcement Strength:** Masonry design shall be based on a reinforcement strength equal to the specified yield strength of reinforcement,  $f_y$ , that shall not exceed 60,000 psi (400 MPa).

**□11.3.11 Section Properties:**

**11.3.11.1:** Member strength shall be computed using section properties based on the minimum net bedded and grouted cores cross-sectional area of the member under consideration.

**11.3.11.2:** Section properties shall be based on specified dimensions.

**□11.3.12 Headed and Bent-Bar Anchor Bolts****8.3.12 PLATE, HEADED AND BENT BAR ANCHOR BOLTS:** All bolts shall be grouted in place with at least 1-inch (25 mm) grout between the bolt and masonry, except that 1/4-inch (6.4 mm) bolts may be placed in bed joints that are at least 1/2 inch (12.7 mm) in thickness.

**11.3.12.1:** The design axial strength,  $B_a$ , for headed *anchor* bolts embedded in masonry shall be the lesser of Eq. 11.3.12.1-1 (strength governed by masonry breakout) or Eq. 11.3.12.1-2 (strength governed by steel):



$$B_a = 4\phi A_p \sqrt{f'_m} \quad (11.3.12.1-1)$$

$$B_a = \phi A_b f_y \quad (11.3.12.1-2)$$

where:

- $B_a$  = design axial strength of the headed anchor bolt, lb;
- $\phi$  = strength reduction factor, where  $\phi = 0.5$  for Eq. 11.3.12.1-1 and  $\phi = 0.9$  for Eq. 11.3.12.1-2;
- $A_p$  = projected area on the masonry surface of a right circular cone, in.<sup>2</sup>;
- $A_b$  = effective tensile stress area of the headed anchor bolt, in.<sup>2</sup>;
- $f'_m$  = specified compressive strength of the masonry, psi; and
- $f_y$  = specified yield strength of the headed anchor bolt, psi.

The metric equivalent of Eq. 11.3.12.1-1 is  $B_a = \phi(0.33A_p\sqrt{f'_m})$  where  $B_a$  is in N,  $A_p$  is in mm<sup>2</sup>, and  $f'_m$  is in MPa. The metric equivalent of Eq. 11.3.12.1-2 is the same except that  $B_a$  is in N,  $A_b$  is in mm<sup>2</sup>, and  $f_y$  is in MPa.

**11.3.12.1.1:** The area  $A_p$  in Eq. 11.3.12.1-1 shall be the lesser of Eq. 11.3.12.1.1-1 or Eq. 11.3.12.1.1-2:

$$A_p = \frac{2}{b} \quad (11.3.12.1.1-1)$$

$$A_p = \frac{2}{l_{be}} \quad (11.3.12.1.1-2)$$

where:

- $A_p$  = projected area on the masonry surface of a right circular cone, in.<sup>2</sup>;
- $l_b$  = effective embedment length of the headed anchor bolt, in.; and
- $l_{be}$  = anchor bolt edge distance, in..

The metric equivalents of Eq. 11.3.12.1.1-1 and Eq. 11.3.12.1.1-2 are the same except that  $A_p$  is in mm<sup>2</sup> and  $l_b$  and  $l_{be}$  are in mm.

Where the projected areas  $A_p$  of adjacent headed anchor bolts overlap, the projected area  $A_p$  of each bolt shall be reduced by one-half of the overlapping area. That portion of the projected area falling in an open cell or core shall be deducted from the value of  $A_p$  calculated using Eq. 11.3.12.1.1-1 or Eq. 11.3.12.1.1-2, whichever is less.

**11.3.12.1.2:** The effective embedment length of a headed bolt,  $l_b$ , shall be the length of embedment measured perpendicular from the surface of the masonry to the head of the *anchor* bolt.

**11.3.12.1.3:** The minimum effective embedment length of headed anchor bolts resisting axial forces shall be 4 bolt diameters or 2 in. (51 mm), whichever is greater.

**11.3.12.2:** The design axial strength,  $B_a$  for bent-bar anchor bolts (J- or L-bolts) embedded in masonry shall be the least of Eq. 11.3.12.2-1 (strength governed by masonry breakout), Eq. 11.3.12.2-2 (strength governed by steel), and Eq. 11.3.12.2-3 (strength governed by anchor pullout):

$$B_a = 4\phi A_p \sqrt{f'_m} \quad (11.3.12.2-1)$$

$$B_a = \phi A_b f_y \quad (11.3.12.2-2)$$

$$B_a = 1.5\phi f'_m e d_b + 200 (l_b + e + d_b) d_b \quad (11.3.12.2-3)$$

where:

- $B_a$  = design axial strength of the bent-bar anchor bolt, lb;
- $\phi$  = strength reduction factor, where  $\phi = 0.5$  for Eq. 11.3.12.2-1,  $\phi = 0.9$  for Eq. 11.3.12.2-2, and  $\phi = 0.65$  for Eq. 11.3.12.2-3;
- $A_p$  = projected area on the masonry surface of a right circular cone, in.<sup>2</sup>;
- $A_b$  = effective tensile stress area of the bent-bar anchor bolt, in.<sup>2</sup>;
- $e$  = projected leg extension of bent-bar anchor bolt, measured from inside edge of *anchor* at bend to farthest point of anchor in the plane of the hook, in.; shall not be taken larger than  $2d_b$  for use in Equation 11.3.12.2-3.
- $d_b$  = nominal diameter of bent-bar anchor bolt, in.
- $l_b$  = effective embedment length of bent-bar anchor bolt, in.
- $f'_m$  = specified compressive strength of the masonry, psi;
- $f_y$  = specified yield strength of the bent-bar anchor bolt, psi.

The metric equivalent of Eq. 11.3.12.2-1 is:

$$B_a = 0.33\phi A_p \sqrt{f'_m}$$

where  $B_a$  is in N,  $A_p$  is in mm<sup>2</sup>, and  $f'_m$  is in MPa. The metric equivalent of Eq. 11.3.12.2-2 is the same except that  $B_a$  is in N,  $A_b$  is in mm<sup>2</sup>, and  $f_y$  is in MPa. The metric equivalent of Eq. 11.3.12.2-3 is:

$$B_a = 1.5\phi f'_m e d_b + 2.05 (l_b + e + d_b) d_b$$

where  $B_a$  is in N,  $e$  and  $d_b$  are in mm, and  $f'_m$  is in MPa. The second term in Eq. 11.3.12.2-3 shall be included only if continuous special inspection is provided during placement per Sec. 11.3.5.2.

**11.3.12.2.1:** The area  $A_p$  in Eq. 11.3.12.2-1 shall be the lesser of Eq. 11.3.12.2.1-1 or Eq. 11.3.12.2.1-2:

$$A_p = l_b^2 \quad (11.3.12.2.1-1)$$

$$A_p = l_{be}^2 \quad (11.3.12.2.1-2)$$

where:

$A_p$  = projected area on the masonry surface of a right circular cone, in.<sup>2</sup>;

$l_b$  = effective embedment length of the bent-bar anchor bolt, in.; and

$l_{be}$  = anchor bolt edge distance, in..

The metric equivalents of Eq. 11.3.12.2.1-1 and Eq. 11.3.12.2.1-2 are the same except that  $A_p$  is in mm<sup>2</sup> and  $l_b$  and  $l_{be}$  are in mm.

Where the projected areas  $A_p$  of adjacent bent-bar anchor bolts overlap, the projected area  $A_p$  of each bolt shall be reduced by one-half of the overlapping area. That portion of the projected area falling in an open cell or core shall be deducted from the value of  $A_p$  calculated using Eq. 11.3.12.2.1-1 or Eq. 11.3.12.2.1-2, whichever is less.

**11.3.12.2.2:** The effective embedment of a bent-bar anchor bolt,  $l_b$ , shall be the length of embedment measured perpendicular from the surface of the masonry to the bearing surface of the bent end, minus one anchor bolt diameter.

**11.3.12.2.3:** The minimum effective embedment length of bent-bar anchor bolts resisting axial forces shall be 4 bolt diameters or 2 in. (51 mm), whichever is greater.

**11.3.12.3:** Where the anchor bolt edge distance,  $l_{be}$ , equals or exceeds 12 bolt diameters, the design shear strength, ( $B_v$ ), shall be the lesser of the values given by Eq. 11.3.12.3-1 (strength governed by masonry) or Eq. 11.3.12.3-2 (strength governed by steel):

$$B_v = 1750\phi \sqrt[4]{f'_m A_b} \quad (11.3.12.3-1)$$

$$B_v = 0.6\phi A_b f_y \quad (11.3.12.3-2)$$

where:

$\phi$  = strength reduction factor, where  $\phi = 0.5$  for Eq. 11.3.12.3-1 and  $\phi = 0.9$  for Eq. 11.3.12.3-2;

$A_b$  = effective tensile stress area of the anchor bolt, in.<sup>2</sup>;

$f'_m$  = specified compressive strength of the masonry, psi, and

$f_y$  = specified yield strength of anchor bolt as applicable, psi.

The metric equivalent of Eq. 11.3.12.3-1 is  $B_v = 5350 \phi \sqrt[4]{f'_m A_b}$  where  $A_b$  is in mm<sup>2</sup> and  $f'_m$  and  $f_y$  are in MPa. The metric equivalent of Eq. 11.3.12.3-2 is the same as that above except that  $A_b$  is in mm<sup>2</sup> and  $f_y$  is in MPa.

Where the anchor bolt edge distance,  $l_{be}$ , is less than 12 bolt diameters, the value of  $B_v$  in Eq. 11.3.12.3-1 shall be reduced by linear interpolation to zero at an  $l_{be}$  distance of 1 in. (25 mm).

**11.3.12.4:** Anchor bolts subjected to combined shear and tension shall be designed to satisfy Eq. 11.3.12.4:

$$\frac{b_a}{B_a} + \frac{b_v}{B_v} \leq 1 \quad (11.3.12.4)$$

where:

$b_a$  = design axial force on the anchor bolt, lb (N);

$B_a$  = design axial strength of the anchor bolt, lb (N);

$b_v$  = design shear force on the anchor bolt, lb (N); and

$B_v$  = design shear strength of the anchor bolt, lb (N).

## **11.4 DETAILS OF REINFORCEMENT:**

### **11.4.1 General:**

**11.4.1.1:** Details of reinforcement shall be shown on the contract documents.

**11.4.1.2:** Reinforcing bars shall be embedded in grout.

### **11.4.2 Size of Reinforcement:**

**11.4.2.1:** Reinforcing bars used in masonry shall not be larger than a No. 9 bar (29 mm diameter).

The bar diameter shall not exceed one-eighth of the nominal *wall* thickness and shall not exceed one-quarter of the least clear dimension of the cell, course, or collar joint in which it is placed. The area of reinforcing bars placed in a cell, or in a course, of hollow unit construction shall not exceed 4 percent of the cell area.

**11.4.2.2:** Longitudinal and cross wire joint reinforcement shall be a minimum W1.1, (0.011 mm<sup>2</sup>) and shall not exceed one-half the joint thickness.

**11.4.3 Placement Limits for Reinforcement:**

**11.4.3.1:** The clear distance between parallel reinforcing bars shall not be less than the nominal diameter of the bars nor less than 1 in. (25 mm).

**11.4.3.2:** In columns and pilasters, the clear distance between vertical reinforcing bars shall not be less than one and one-half times the nominal bar diameter, nor less than 1-1/2 in. (38 mm).

**11.4.3.3:** The clear distance limitations between reinforcing bars shall also apply to the clear distance between a contact lap splice and adjacent splices or bars.

**11.4.3.4:** Reinforcing bars shall not be bundled.

**11.4.4 Cover for Reinforcement:**

**11.4.4.1:** Reinforcing bars shall have a minimum thickness of masonry and grout cover not less than 2-1/2  $d_b$  nor less than the following:

- a. Where the masonry face is exposed to earth or weather, 2 in. (51 mm) for bars larger than No. 5 (16 mm) and 1-1/2 in. (38 mm) for No. 5 (16 mm) bar or smaller.
- b. Where the masonry is not exposed to earth or weather, 1-1/2 in. (38 mm).

**11.4.4.2:** The minimum grout thickness between reinforcing bars and masonry units shall be 1/4 in. (6 mm) for fine grout or 1/2 in. (12 mm) for coarse grout.

**11.4.4.3:** Longitudinal wires of joint reinforcement shall be fully embedded in mortar or grout with a minimum cover of 1/2 in. (13 mm) when exposed to earth or weather and 3/8 in. (10 mm) when not exposed to earth or weather. Joint reinforcement in masonry exposed to earth or weather shall be corrosion resistant or protected from corrosion by coating.

**11.4.4.4:** *Wall* ties, anchors, and inserts, except anchor bolts not exposed to the weather or moisture, shall be protected from corrosion.

**11.4.5 Development of Reinforcement:**

**11.4.5.1 General:** The calculated tension or compression in the reinforcement where masonry reinforcement is anchored in concrete shall be developed in the concrete by embedment length, hook or mechanical device or a combination thereof. Hooks shall only be used to develop bars in tension.

**11.4.5.2 Embedment of Reinforcing Bars and Wires in Tension:** The embedment length,  $l_d$ , of reinforcing bars and wire shall be determined by Eq. 11.4.5.2 but shall not be less than 12 in. (305 mm) for bars and 6 in. (152 mm) for wire:

$$l_d = \left( \frac{1}{\phi} \right) \left( \frac{0.15 d_b^2 f_y}{K \sqrt{f'_m}} \right) \leq \frac{52 d_b}{\phi} \quad (11.4.5.2)$$

where:

- $\phi$  = strength reduction factor as given in Table 11.5.3;  
 $d_b$  = diameter of the reinforcement, in.;

$K$  = the lesser of the clear spacing between adjacent reinforcement, or 3 times  $d_b$ , in.;

$f'_m$  = specified compressive strength of masonry, psi; and

$f_y$  = specified yield strength of the reinforcement, psi.

The metric equivalent of Eq. 11.4.5.2 is  $l_d = \left(\frac{1}{\Phi}\right) \left(\frac{1.8d_b^2 f_y}{K\sqrt{f'_m}}\right) \leq \frac{52d_b}{\Phi}$  where  $l_d$  and  $d_b$  are in mm and  $f_y$

and  $f'_m$  are in MPa.

### 11.4.5.3 Standard Hooks:

**11.4.5.3.1:** The term standard hook as used in this code shall mean one of the following:

**11.4.5.3.1.1:** A 180-degree turn plus extension of at least 4 bar diameters but not less than 2-1/2 in. (64 mm) at free end of bar.

**11.4.5.3.1.2:** A 135-degree turn plus extension of at least 6 bar diameters at free end of bar.

**11.4.5.3.1.3:** A 90-degree turn plus extension of at least 12 bar diameters at free end of bar.

**11.4.5.3.1.4:** For *stirrup* and tie anchorage only, either a 135-degree or a 180-degree turn plus an extension of at least 6 bar diameters at the free end of the bar.

**11.4.5.3.2:** The equivalent embedment length for standard hooks in tension,  $l_{dh}$ , shall be as follows:

$$l_{dh} = 13d_b \quad (11.4.5.3.2)$$

where  $d_b$  = diameter of the reinforcement, in. The metric equivalent of Eq. 11.4.5.3.2 is the same except that  $d_b$  is in mm.

**11.4.5.3.3:** The effect of hooks for bars in compression shall be neglected in design computations.

### 11.4.5.4 Minimum Bend Diameter for Reinforcing Bars:

**11.4.5.4.1:** The diameter of bend measured on the inside of the bar, other than for *stirrups* and ties, shall not be less than values specified in Table 11.4.5.4.1.

**TABLE 11.4.5.4.1 Minimum Diameters of Bend**

Bar Size	Grade	Minimum Bend
No. 3 (10 mm) through No. 7 (22 mm)	40	5 bar diameters
No. 3 (10 mm) through No. 8 (25 mm)	50 or 60	6 bar diameters
No. 9 (29 mm)	50 or 60	8 bar diameters

### 11.4.5.5 Development of Shear Reinforcement:

**11.4.5.5.1:** Shear reinforcement shall extend the depth of the member less cover distances.

**11.4.5.5.2:** The ends of single leg or U-stirrups shall be anchored by one of the following means:

- a. A standard hook plus an effective embedment of 0.5 times the development length,  $l_d$ . The effective embedment of a *stirrup* leg shall be taken as the distance between the mid-depth of the member, and the start of the hook (point of tangency).
- b. For No. 5 (16 mm) bar and D31 wire and smaller, bending around longitudinal reinforcement through at least 135 degrees plus an embedment of  $l_d/3$ . The  $l_d/3$  embedment of a *stirrup* leg shall be taken as the distance between mid-depth of member, and the start of the hook (point of tangency).
- c. Between the anchored ends, each bend in the continuous portion of a transverse U-stirrup shall enclose a longitudinal bar.

**11.4.5.5.3:** Except at wall intersections, the end of a reinforcing bar needed to satisfy shear strength requirements in accordance with Sec. 11.7.3.3 shall be bent around the edge vertical reinforcing bar with a 180-degree hook. At *wall* intersections, reinforcing bars used as shear reinforcement shall be bent around the edge vertical bar with a 90-degree standard hook and shall extend horizontally into the intersecting *wall*.

**11.4.5.6 Splices of Reinforcement:** Lap splices, welded splices, or mechanical connections shall be in accordance with the provisions of this section.

**11.4.5.6.1 Lap Splices:** Lap splices shall not be used in plastic hinge zones. The length of the plastic hinge zone shall be taken as at least 0.15 times the distance between the point of zero moment and the point of maximum moment.

**11.4.5.6.1.1:** The minimum length of lap,  $l_{db}$ , for bars in tension or compression shall be equal to the development length,  $l_d$ , as determined by Eq. 11.4.5.2 but shall not be less than 12 in. (305 mm) for bars and 6 in (152 mm) for wire.

**11.4.5.6.1.2:** Bars spliced by noncontact lap splices shall not be spaced transversely farther apart than one-fifth the required length of lap nor more than 8 in. (203 mm).

**11.4.5.6.2 Welded Splices:** A welded splice shall be capable of developing in tension 125 percent of the specified yield strength,  $f_y$ , of the bar.

**11.4.5.6.3 Mechanical Connections:** Mechanical splices shall have the bars connected to develop in tension or compression, as required, at least 125 percent of the specified yield strength of the bar.

**11.4.5.6.4 End Bearing Splices:**

**11.4.5.6.4.1:** In bars required for compression only, the transmission of compressive stress by bearing of square cut ends held in concentric contact by a suitable device is permitted.

**11.4.5.6.4.2:** Bar ends shall terminate in flat surfaces within 1-1/2 degrees of a right angle to the axis of the bars and shall be fitted within 3 degrees of full bearing after assembly.

**11.4.5.6.4.3:** End bearing splices shall be used only in members containing closed ties, closed stirrups or spirals.

## **11.5 STRENGTH AND DEFORMATION REQUIREMENTS:**

**11.5.1 General:** Masonry *structures* and masonry members shall be designed to have strength at all sections at least equal to the *required strength* calculated for the factored loads in such combinations as are stipulated in these provisions.

**11.5.2 Required Strength:** The *required strength* shall be determined in accordance with Chapters 2 and 3.

**11.5.3 Design Strength:** *Design strength* provided by a member and its connections to other members and its cross sections in terms of flexure, axial load, and shear shall be taken as the *nominal strength* multiplied by a strength reduction factor,  $\phi$ , as specified in Table 11.5.3.



**TABLE 11.5.3 Strength Reduction Factor  $\phi$** 

Axial Load, Flexure, and Combinations of Axial Load and Flexure	Reinforced masonry	$\phi = 0.85$
	Plain masonry	$\phi = 0.60$
Shear	Reinforced masonry	$\phi = 0.80$
Shear	Plain masonry	$\phi = 0.80$
Reinforcement development length and splices		$\phi = 0.80$
Anchor bolt strength as governed by steel		$\phi = 0.90$
Anchor bolt strength as governed by masonry		$\phi = 0.50$
Bearing		$\phi = 0.60$

**11.5.4 Deformation Requirements:**

**11.5.4.1:** Masonry structures shall be designed so the design story drift,  $\delta_d$ , does not exceed the allowable story drift,  $\delta_{a,n}$ , obtained from Table 5.2.8.

**11.5.4.1.1:** Cantilever shear walls shall be proportioned such that the maximum displacement,  $\delta_{max}$ , at Level  $n$  does not exceed  $0.01h_n$ .

**11.5.4.2:** Deflection calculations for plain masonry members shall be based on uncracked section properties.

**11.5.4.3:** Deflection calculations for reinforced masonry members shall be based on an effective moment of inertia in accordance with the following:

$$I_{eff} = I_n \left( \frac{M_{cr}}{M_a} \right)^3 + I_{cr} \left[ 1 - \left( \frac{M_{cr}}{M_a} \right)^3 \right] \leq I_n \quad (11.5.4.3)$$

where:

$$M_{cr} = Sf_r;$$

$M_{cr}$  = cracking moment strength of the masonry, in.-lb;

$M_a$  = maximum moment in the member at the stage deflection is computed, in.-lb;

$I_{cr}$  = moment of inertia of the cracked section, in.<sup>4</sup>;

$I_n$  = moment of inertia of the net cross-sectional area of the member, in.<sup>4</sup>;

$S$  = uncracked section modulus of the wall, in.<sup>3</sup>; and

$f_r$  = modulus of rupture of masonry, psi.

The metric equivalent of Eq. 11.5.4.3 is the same except that  $M_{cr}$  and  $M_a$  are in (N-mm),  $I_{cr}$  and  $I_n$  are in mm<sup>4</sup>,  $S$  is in mm<sup>3</sup>, and  $f_r$  is in MPa.

**11.5.4.4:** The calculated deflection shall be multiplied by  $C_d$  for determining drift.

**11.6 FLEXURE AND AXIAL LOADS:**

**11.6.1 Scope** **8.6.1 SCOPE:** This section shall apply to the design of masonry members subject to flexure or axial loads or to combined flexure and axial loads.

**11.6.2 Design Requirements of Reinforced Masonry Members:**

**11.6.2.1:** Strength design of members for flexure and axial loads shall be in accordance with principles of engineering mechanics, and in accordance with the following design assumptions:

- a. Strain in reinforcement and masonry shall be assumed directly proportional to the distance from the neutral axis, except for deep flexural members with overall depth to clear span ratio greater than 2/5 for continuous span members and 4/5 for simple span members where a nonlinear distribution of strain shall be considered.
- b. Maximum usable strain,  $\epsilon_{mu}$ , at the extreme masonry compression fiber shall be assumed equal to 0.0025 for concrete masonry and 0.0035 for clay-unit masonry.
- c. Stress in reinforcement below the *specified* yield strength,  $f_y$ , shall be taken as the modulus of elasticity,  $E_s$ , times the steel strain. For strains greater than those corresponding to the *specified* yield strength,  $f_y$ , the stress in the reinforcement shall be considered independent of strain and equal to the *specified* yield strength,  $f_y$ .
- d. Tensile strength of masonry shall be neglected in calculating the flexural strength of a *reinforced masonry* cross section.
- e. Flexural compression in masonry shall be assumed to be an equivalent rectangular stress block. Masonry stress of 0.80 times the *specified* compressive strength,  $f'_m$  shall be assumed to be uniformly distributed over an equivalent compression zone bounded by edges of the cross section and a straight line located parallel to the neutral axis at a distance  $a = 0.80 c$  from the fiber of maximum compressive strain.

**11.6.2.2:** The ratio of reinforcement,  $r$ , shall not exceed the lesser ratio as calculated with either of the following two that will cause the following critical strain conditions

1. For walls subjected to in-plane forces, columns and beams, the critical strain condition corresponds to a strain in the extreme tension reinforcement equal to 5 times the strain associated with the reinforcement yield stress,  $f_y$ .
2. For walls subjected to out-of-plane forces, the critical strain condition corresponds to a strain in the extreme tension reinforcement equal to 1.3 times the strain associated with the reinforcement yield stress,  $f_y$ .

For both cases, the strain at the extreme compression fiber shall be assumed to be either 0.0035 in./in. for clay masonry or 0.0025 in./in. for concrete masonry.

The calculation of the maximum reinforcement ratio shall include unfactored gravity axial loads. The stress in the tension reinforcement shall be assumed to be  $1.25f_y$ . Tension in the masonry shall be neglected. The strength of the compressive zone shall be calculated as 80 percent of  $f'_m$  times 80 percent of the area of the compressive zone. Stress in reinforcement in the compression zone shall be based on a linear strain distribution.

**11.6.2.3:** Members subject to compressive axial load shall be designed for the maximum moment that can accompany the axial load. The required moment,  $M_u$ , shall include the moment induced by relative lateral displacements.

### 11.6.3 Design of Plain (Unreinforced) Masonry Members:

**11.6.3.1:** Strength design of members for flexure and axial load shall be in accordance with principles of engineering mechanics .

**11.6.3.2:** Strain in masonry shall be assumed directly proportional to the distance from the neutral axis.

**11.6.3.3:** Flexural tension in masonry shall be assumed directly proportional to strain.

**11.6.3.4:** Flexural compressive stress in combination with axial compressive stress in masonry shall be assumed directly proportional to strain. Maximum compressive stress shall not exceed  $0.85f'_m$ .

**11.6.3.5:** Design axial load strength shall be in accordance with Eq. 11.6.3.5-1 or Eq. 11.6.3.5-2:

$$\phi P_n = \phi A_n f'_m \left[ 1 - \left( \frac{h}{140r} \right)^2 \right] \text{ for } h/r < 99 \quad (11.6.3.5-1)$$

$$\phi P_n = \phi A_n f'_m \left( \frac{70r}{h} \right)^2 \text{ for } h/r \geq 99 \quad (11.6.3.5-2)$$

where:

- $\phi$  = strength reduction factor per Table 11.5.3;
- $A_n$  = net cross-sectional area of the masonry, in.<sup>2</sup>;
- $f'_m$  = specified compressive strength of the masonry, psi;
- $h$  = effective height of the wall between points of support, in. and
- $r$  = radius of gyration, inches.

The metric equivalents for Eq. 11.6.3.5-1 and Eq. 11.6.3.5-2 are the same except that  $A_n$  is in mm<sup>2</sup>,  $f'_m$  is in MPa, and  $h$  and  $r$  are in mm.

## 11.7 SHEAR:

**11.7.1 Scope:** Provisions of this section shall apply for design of members subject to shear.

### 11.7.2 Shear Strength:

**11.7.2.1:** Design of cross sections subjected to shear shall be based on:

$$V_u \leq \phi V_n \quad (11.7.2.1)$$

where:

- $V_u$  = required shear strength due to factored loads, lb.

$\phi$  = strength reduction factor per Table 11.5.3; and

$V_n$  = nominal shear strength, lb.

The metric equivalent of Eq. 11.7.2.1 is the same except that  $V_u$  and  $V_n$  are in N.

**11.7.2.2:** The design shear strength,  $\phi V_n$ , shall exceed the shear corresponding to the development of 1.25 times the nominal flexural strength of the member, except that the nominal shear strength need not exceed 2.5 times  $V_u$ .

### 11.7.3 Design of Reinforced Masonry Members:

**11.7.3.1:** Nominal shear strength,  $V_n$ , shall be computed as follows:

$$\text{where:} \quad V_n = V_m + V_s \quad (11.7.3.1-1)$$

$V_n$  = nominal shear strength, lb;

$V_m$  = nominal shear strength provided by masonry, lb; and

$V_s$  = shear strength provided by reinforcement, lb.

The metric equivalent for Eq. 11.7.3.1-1 is the same except that  $V_n$ ,  $V_m$ , and  $V_s$  are in N.

For  $M/Vd_v < 0.25$ :

$$V_{n(\max)} = 6\sqrt{f'_m} A_n \quad (11.7.3.1-2)$$

For  $M/Vd_v < 1.00$ :

$$V_{n(\max)} = 4\sqrt{f'_m} A_n \quad (11.7.3.1-3)$$

where:

$V_{n(\max)}$  = maximum nominal shear strength, lb;

$A_n$  = net cross-sectional area of the masonry, in.<sup>2</sup>;

$f'_m$  = specified compressive strength of the masonry, psi;

$M$  = moment on the masonry section due to unfactored design loads, in.-lb;

$V$  = shear on the masonry section due to unfactored loads, lb; and

$d_v$  = length of member in direction of shear force, inches.

Values of  $M/Vd_v$  between 0.25 and 1.0 may be interpolated.

The metric equivalent of Eq. 11.7.3.1-2 is  $V_{n(\max)} = 0.5\sqrt{f'_m}A_n$  and the metric equivalent of Eq. 11.7.3.1-3 is  $V_{n(\max)} = 0.33\sqrt{f'_m}A_n$  where  $V_{n(\max)}$  is in N,  $A_n$  is in mm<sup>2</sup>,  $f'_m$  is in MPa,  $M$  is in N-mm, and  $d$  is in mm.

**11.7.3.2:** Shear strength,  $V_m$ , provided by masonry shall be as follows:

$$V_m = \left[ 4.0 - 1.75 \left( \frac{M}{Vd} \right) \right] A_n \sqrt{f'_m} + 0.25P \quad (11.7.3.2)$$

where  $M/Vd_v$  need not be taken greater than 1.0 and

- $V_m$  = shear strength provided by masonry, lb;  
 $M$  = moment on the masonry section due to unfactored design loads, in.-lb;  
 $V$  = shear on the masonry section due to unfactored loads, psi;  
 $d_v$  = length of member in direction of shear force, in.;  
 $A_n$  = net cross-sectional area of the masonry, in.<sup>2</sup>;  
 $f'_m$  = specified compressive strength of the masonry, psi; and  
 $P$  = axial load on the masonry section due to unfactored design loads, lb.

The metric equivalent of Eq. 11.7.3.2 is  $V_m = 0.083 \left[ 4.0 - 1.75 \left( \frac{M}{Vd} \right) \right] A_n \sqrt{f'_m} + 0.25P$  where

$V_m$  and  $P$  are in N,  $M$  is in N-mm,  $f'_m$  is in MPa,  $d$  is in mm, and  $A_n$  is in mm<sup>2</sup>.

**11.7.3.3:** Nominal shear strength,  $V_s$ , provided by reinforcement shall be as follows:

$$V_s = 0.5 \left( \frac{A_v}{s} \right) f_y d_v \quad (11.7.3.3)$$

where:

- $A_v$  = area of shear reinforcement, in.<sup>2</sup> (mm<sup>2</sup>)  
 $d_v$  = length of member in direction of shear force, in. (mm)  
 $s$  = spacing of shear reinforcement, in. (mm); and  
 $f_y$  = specified yield strength of the reinforcement or the anchor bolt as applicable, psi (MPa).

The metric equivalent of Eq. 11.7.3.3 is the same.

#### 11.7.4 Design of Plain (Unreinforced) Masonry Members:

**11.7.4.1:** Nominal shear strength,  $V_n$ , shall be the lesser of the following:

- $0.5\sqrt{f'_m}A_n$ , lb (the metric equivalent is  $0.125\sqrt{f'_m}A_n$ , N, where  $f'_m$  is in MPa and  $A_n$  is in mm<sup>2</sup>);
- $120A_n$ , lb (the metric equivalent is  $0.83A_n$ , N; where  $A_n$  is in mm<sup>2</sup>);
- $37 A_n + 0.3 N_v$  for *running bond* masonry not grouted solid, lb (the metric equivalent is  $0.26A_n + 0.3N_v$  when  $A_n$  is in mm<sup>2</sup> and  $N_v$  is in N);

$37 A_n + 0.3 N_v$  for *stack bond* masonry with open end units and grouted solid, lb (the metric equivalent is  $0.26A_n + 0.3N_v$  when  $A_n$  is in  $\text{mm}^2$  and  $N_v$  is in N);

$60 A_n + 0.3 N_v$  for *running bond* masonry grouted solid, lb (the metric equivalent is  $0.414A_n + 0.3N_v$  when  $A_n$  is in  $\text{mm}^2$  and  $N_v$  is in N); and

$15 A_n$  for *stack bond* other than open end units grouted solid, lb (the metric equivalent is  $0.103A_n + 0.3N_v$  when  $A_n$  is in  $\text{mm}^2$  and  $N_v$  is in N)

where:

$f'_m$  = specified compressive strength of the masonry, psi;

$A_n$  = net cross-sectional area of the masonry,  $\text{in.}^2$ ; and

$N_v$  = force acting normal to shear surface, lb.

### 11.8 SPECIAL REQUIREMENTS FOR BEAMS:

**11.8.1:** The spacing between lateral supports shall be determined by the requirements for out of-plane loading, but it shall not exceed 32 times the least width of beam.

**11.8.2:** The effects of lateral eccentricity of load shall be taken into account in determining spacing of lateral supports.

**11.8.3:** The minimum positive reinforcement ratio  $r$  in a beam shall not be less than  $120/f_y$  (the metric equivalent is  $0.83/f_y$  where  $f_y$  is in MPa) except that this minimum positive steel reinforcement ratio need not be satisfied if the area of reinforcement provided is one third greater than that required by analysis for *gravity loads* and the *Seismic Design Category* is A, B, or C.

Where a concrete floor provides a flange and where the beam web is in tension, the ratio shall be computed using the web width.

#### 11.8.4 Deep Flexural Members:

**11.8.4.1:** Flexural members with overall depth to clear span ratios greater than 2/5 for continuous spans or 4/5 for simple spans shall be designed as deep flexural members taking into account nonlinear distribution of strain and lateral buckling.

**11.8.4.2:** Minimum flexural tension reinforcement shall conform to Sec. 11.8.3.

**11.8.4.3:** Uniformly distributed horizontal and vertical reinforcement shall be provided throughout the length and depth of deep flexural members such that the reinforcement ratios in both directions are at least 0.001. Distributed flexural reinforcement is to be included in the determination of the actual reinforcement ratios.

### 11.9 SPECIAL REQUIREMENTS FOR COLUMNS:

**11.9.1:** Area of longitudinal reinforcement for *columns* shall be not less than 0.005 nor more than 0.04 times cross-sectional area of the *column*.

**11.9.2:** There shall be a minimum of four longitudinal bars in *columns*.

**11.9.3:** Lateral ties shall be provided to resist shear and shall comply with the following:

- a. Lateral ties shall be at least 1/4 in. (6 mm) in diameter.
- b. Vertical spacing of lateral ties shall not exceed 16 longitudinal bar diameters, 48 lateral tie diameters, nor the least cross sectional dimension of the column.
- c. Lateral ties shall be arranged such that every corner and alternate longitudinal bar shall have lateral support provided by the corner of a lateral tie with an included angle of not more than 135 degrees and no bar shall be farther than 6 in. (152 mm) clear on each side along the lateral tie from such a laterally supported bar. Lateral ties shall be placed in either a mortar joint or grout. Where longitudinal bars are located around the perimeter of a circle, a complete circular lateral tie is permitted. Minimum lap length for circular ties shall be 84 tie diameters.
- d. Lateral ties shall be located vertically not more than one-half lateral tie spacing above the top of footing or slab in any story and shall be spaced as provided herein to not more than one-half a lateral tie spacing below the lowest horizontal reinforcement in beam, girder, slab or drop panel above.
- e. Where beams or brackets frame into a column from four directions, lateral ties may be terminated not more than 3 in. (76 mm) below lowest reinforcement in the shallowest of such beams or brackets.

#### **11.10 SPECIAL REQUIREMENTS FOR WALLS:**

**11.10.1:** The nominal flexural strength of the *wall* for out-of-plane flexure shall be at least equal to 1.3 times the cracking moment strength of the *wall*.

#### **11.11 SPECIAL REQUIREMENTS FOR SHEAR WALLS:**

**11.11.1 Ordinary Plain Masonry Shear Walls:** The design of *ordinary plain masonry shear walls* shall be in accordance with Sec. 11.3.2 or Sec. 11.3.3. No reinforcement is required to resist seismic forces.

**11.11.2 Detailed Plain Masonry Shear Walls:** The design of *detailed plain masonry shear walls* shall be in accordance with Sec. 11.3.3. *Detailed plain masonry shear walls* shall have minimum amounts of reinforcement as prescribed in Sections 11.3.7.3 and 11.3.7.4.

**11.11.3 Ordinary Reinforced Masonry Shear Walls:** The design of *ordinary reinforced masonry shear walls* shall be in accordance with Sec. 11.3.4. No prescriptive seismic reinforcement is required for *ordinary reinforced masonry shear walls*

**11.11.4 Intermediate Reinforced Masonry Shear Walls:** The design of *intermediate reinforced masonry shear walls* shall be in accordance with Sec. 11.3.4. *Intermediate reinforced masonry shear walls* shall have minimum amounts of reinforcement as prescribed in Sec. 11.3.7.3 and 11.3.7.4.

**11.11.5 Special Reinforced Masonry Shear Walls:** *Special reinforced masonry shear walls* shall meet the requirements for *intermediate reinforced masonry shear walls* (Sec. 11.11.4) in addition to the requirements of this section.

The design of *special reinforced masonry shear walls* shall be in accordance with Sec. 11.3.4. *Special reinforced masonry shear walls* shall comply with material requirements of Sec. 11.3.8, minimum reinforcement requirements of Sec. 11.3.8.3 and 11.3.8.4, and minimum thickness requirements of Sec.

11.3.8.5. In addition, *special reinforced masonry shear walls* shall be reinforced and constructed as required in this section.

**11.11.5.1 Vertical Reinforcement:** The maximum spacing of vertical reinforcement in an *special reinforced masonry shear wall* shall be the smaller of:

- a. One-third the length of the wall
- b. One-third the height of the wall
- c. 48 in. (1219 mm).

**11.11.5.2 Horizontal Reinforcement:** Reinforcement required to resist in-plane shear in a *special reinforced masonry shear wall* shall be placed horizontally, shall be uniformly distributed, and shall be embedded in grout. The maximum spacing of horizontal reinforcement shall be the smaller of:

- a. One-third the length of the wall
- b. One-third the height of the wall
- c. 48 in. (1219 mm)
- d. 24 in. (610 mm) for stack bond masonry.

**11.11.5.3 Shear Keys:** The surface of concrete upon which an *special reinforced masonry shear wall* is constructed shall have a minimum surface roughness of 1/8 inch (3.0 mm). Keys with the following minimum requirements shall be placed at the base of *special reinforced masonry shear walls* when the calculated strain in vertical reinforcement exceeds the yield strain under load combinations that include seismic forces based on a *R* factor equal to 1.5.

- a. The width of the keys shall be at least equal to the width of the grout space
- b. The depth of the keys shall be at least 1.5 inches (40 mm)
- c. The length of the key shall be at least 6 inches (152 mm)
- d. The spacing between keys shall be at least equal to the length of the key
- e. The cumulative length of all keys shall be at least 20% of the length of the shear wall
- f. A minimum of one key shall be placed within 16 inches (406 mm) of each end of a shear wall
- g. Each key and the grout space above each key in the first course of masonry shall be grouted solid.

**11.11.6: Flanged Shear Walls:**

**11.11.6.1:** *Wall* intersections shall be considered effective in transferring shear when either conditions (a) or (b) and condition (c) as noted below are met:

- a. The face shells of hollow masonry units are removed and the intersection is fully grouted.
- b. Solid units are laid in running bond and 50 percent of the masonry units at the intersection are interlocked.
- c. Reinforcement from one intersecting *wall* continues past the intersection a distance not less than 40 bar diameters or 24 inches (600 mm).



**11.11.6.2:** The width of flange considered effective in compression on each side of the web shall be taken equal to 6 times the thickness of the web or shall be equal to the actual flange on either side of the web *wall*, whichever is less.

**11.11.6.3:** The width of flange considered effective in tension on each side of the web shall be taken equal to 3/4 of the *wall* height or shall be equal to the actual flange on either side of the web *wall*, whichever is less.

### 11.11.7 Coupled Shear Walls:

**11.11.7.1 Design of Coupled Shear Walls:** Structural members which provide coupling between *shear walls* shall be designed to reach their moment or shear *nominal strength* before either *shear wall* reaches its moment or shear *nominal strength*. Analysis of coupled *shear walls* shall conform to accepted principles of mechanics.

**11.11.7.2 Shear Strength of Coupling Beams:** The nominal shear strength,  $V_n$ , of the coupling beams shall exceed the shear calculated:

$$V_n \geq \frac{M_1 + M_2}{L_c} + V_g \quad (11.11.7.2)$$

where:

$V_n$	=	nominal shear strength, lb (N);
$M_1$ and $M_2$	=	nominal moment strength at the ends of the beam, lb-in. (N-mm);
$L_c$	=	length of the beam between the <i>shear walls</i> , in. (mm); and
$V_g$	=	shear force due to gravity loads, lb (N).

The metric equivalent of Eq. 11.11.5.2 is the same except that  $V_n$  and  $V_g$  are in N,  $M_1$  and  $M_2$  are in N-mm, and  $L_c$  is in mm.

The calculation of the nominal flexural moment shall include the reinforcement in reinforced concrete roof and floor system. The width of the reinforced concrete used for calculations of reinforcement shall be six times the floor or roof slab thickness.

## 11.12 SPECIAL MOMENT FRAMES OF MASONRY:

**11.12.1 Calculation of Required Strength:** The calculation of required strength of the members shall be in accordance with principles of engineering mechanics and shall consider the effects of the relative stiffness degradation of the beams and columns.

**11.12.2 Flexural Yielding:** Flexural yielding shall be limited to the beams at the face of the *columns* and to the bottom of the columns at the base of the *structure*.

### 11.12.3 Reinforcement:

**11.12.3.1:** The nominal moment strength at any section along a member shall not be less than 1/2 of the higher moment strength provided at the two ends of the member.

**11.12.3.2:** Lap splices are permitted only within the center half of the member length.

**11.12.3.3:** Welded splices and mechanical connections may be used for splicing the reinforcement at any section, provided not more than alternate longitudinal bars are spliced at a section, and the distance between splices on alternate bars is at least 24 in. (610 mm) along the longitudinal axis.

**11.12.3.4:** Reinforcement shall have a specified yield strength of 60,000 psi (414 MPa). The actual yield strength shall not exceed 1.5 times the specified yield strength.

**11.12.4 Wall Frame Beams:**

**11.12.4.1:** Factored axial compression force on the beam shall not exceed 0.10 times the net cross-sectional area of the beam,  $A_n$ , times the specified compressive strength,  $f'_m$ .

**11.12.4.2:** Beams interconnecting vertical elements of the lateral-load-resisting system shall be limited to a reinforcement ratio of  $0.15f'_m/f_y$  or that determined in accordance with Sec. 11.6.2.2. All reinforcement in the beam and adjacent to the beam in a reinforced concrete roof or floor system shall be used to calculate the reinforcement ratio.

**11.12.4.3:** Clear span for the beam shall not be less than 4 times its depth.

**11.12.4.4:** Nominal depth of the beam shall not be less than 4 units or 32 in. (813 mm), whichever is greater. The nominal depth to nominal width ratio shall not exceed 4.

**11.12.4.5:** Nominal width of the beams shall equal or exceed all of the following criteria:

- a. 8 in. (203 mm),
- b. width required by Sec. 11.8.1, and
- c.  $1/26$  of the clear span between *column* faces.

**11.12.4.6 Longitudinal Reinforcement:**

**11.12.4.6.1:** Longitudinal reinforcement shall not be spaced more than 8 in. (203 mm) on center.

**11.12.4.6.2:** Longitudinal reinforcement shall be uniformly distributed along the depth of the beam.

**11.12.4.6.3:** In lieu of the limitations of Sec. 11.8.2, the minimum reinforcement ratio shall be  $130/f_y$  (the metric equivalent is  $0.90/f_y$  where  $f_y$  is in MPa).

**11.12.4.6.4:** At any section of a beam, each masonry unit through the beam depth shall contain longitudinal reinforcement.

**11.12.4.7 Transverse Reinforcement:**

**11.12.4.7.1:** Transverse reinforcement shall be hooked around top and bottom longitudinal bars and shall be terminated with a standard 180-degree hook.

**11.12.4.7.2:** Within an end region extending one beam depth from *wall* frame column faces and at any region at which beam plastic hinges may form during seismic or wind loading, maximum spacing of transverse reinforcement shall not exceed one-fourth the nominal depth of the beam.

**11.12.4.7.3:** The maximum spacing of transverse reinforcement shall not exceed  $1/2$  the nominal depth of the beam or that required for shear strength.

**11.12.4.7.4:** Minimum transverse reinforcement ratio shall be 0.0015.

**11.12.4.7.5:** The first transverse bar shall not be more than 4 inches (102 mm) from the face of the pier.

**11.12.5 Wall Frame Columns:**

**11.12.5.1:** Factored axial compression force on the *wall* frame column shall not exceed 0.15 times the net cross-sectional area of the column,  $A_n$ , times the specified compressive strength,  $f'_m$ . The compressive stress shall also be limited by the maximum reinforcement ratio.

**11.12.5.2:** *Nominal dimension* of the column parallel to the plane of the *wall* frame shall not be less than two full units or 32 in. (810 mm), whichever is greater.

**11.12.5.3:** *Nominal dimension* of the column perpendicular to the plane of the *wall* frame shall not be less than 8 in. (203 mm) nor 1/14 of the clear height between beam faces.

**11.12.5.4:** The clear height-to-depth ratio of column members shall not exceed 5.

**11.12.5.5 Longitudinal Reinforcement:**

**11.12.5.5.1:** A minimum of 4 longitudinal bars shall be provided at all sections of every *wall* frame column member.

**11.12.5.5.2:** The flexural reinforcement shall be uniformly distributed across the member depth.

**11.12.5.5.3:** The nominal moment strength at any section along a member shall be not less than 1.6 times the cracking moment strength and the minimum reinforcement ratio shall be  $130/f_y$  (the metric equivalent is  $0.90/f_y$  where  $f_y$  is in MPa).

**11.12.5.5.4:** Vertical reinforcement in wall-frame columns shall be limited to a maximum reinforcement ratio equal to the lesser of  $0.15f'_m / F_y$  or that determined in accordance with Sec. 11.6.2.2.

**11.12.5.6 Transverse Reinforcement:**

**11.12.5.6.1:** Transverse reinforcement shall be hooked around the extreme longitudinal bars and shall be terminated with a standard 180-degree hook.

**11.12.5.6.2:** The spacing of transverse reinforcement shall not exceed 1/4 the nominal dimension of the column parallel to the plane of the *wall* frame.

**11.12.5.6.3:** Minimum transverse reinforcement ratio shall be 0.0015.

**11.12.6 Wall Frame Beam-Column Intersection:**

**11.12.6.1:** Beam-column intersection dimensions in masonry wall frames shall be proportioned such that the wall frame column depth in the plane of the frame satisfies Eq. 11.12.6.1-1:

$$h_p > \frac{4,800 d_{bp}}{\sqrt{f'_s}} \quad (11.12.6.1-1)$$

where:

$h_p$  = pier depth in the plane of the wall frame, in.;

$d_{bb}$  = diameter of the largest beam longitudinal reinforcing bar passing through, or anchored in, the wall frame beam-column intersection, in.; and

$f'_g$  = specified compressive strength of grout, psi (shall not exceed 5,000 psi (34.5 MPa) for use in Eq. 11.12.7.1-1).

The metric equivalent of Eq. 11.12.6.1-1 is  $h_p > \frac{400d_{bb}}{\sqrt{f'_g}}$  where  $h_p$  and  $d_{bb}$  are in mm and  $f'_g$  is in MPa.

Beam depth in the plane of the frame shall satisfy Eq. 11.1.2.7.1-2:

$$h_b > \frac{1800d_{bp}}{\sqrt{f'_g}} \quad (11.12.7.1.2)$$

where:

$h_b$  = beam depth in the plane of the wall frame, in.;

$d_{bp}$  = diameter of the largest *column* (pier) longitudinal reinforcing bar passing through, or anchored in, the wall frame beam-column intersection, in.; and

$f'_g$  = specified compressive strength of grout, psi (shall not exceed 5,000 psi (34.2MPa) for use in Eq. 11.12.7.1-1).

The metric equivalent of Eq. 11.12.7.1-2 is  $h_b > \frac{150d_{bp}}{\sqrt{f'_g}}$  where  $h_b$  and  $d_{bp}$  are in mm and  $f'_g$  is in

MPa.

Nominal shear strength of beam-column intersections shall exceed the shear occurring when wall frame beams develop their nominal flexural strength.

**11.12.6.2:** Beam longitudinal reinforcement terminating in a wall frame column shall be extended to the far face of the *column* and shall be anchored by a standard hook bent back into the wall frame column.

Special horizontal shear reinforcement crossing a potential diagonal beam *column* shear crack shall be provided such that:

$$A_s \geq \frac{0.5V_n}{f_y} \quad (11.12.6.2)$$

where:

$A_s$  = cross-sectional area of reinforcement in.<sup>2</sup>;

$V_n$  = nominal shear strength, lb; and

---

$f_y$  = specified yield strength of the reinforcement or the *anchor* bolt as applicable, psi.

The metric equivalent of Eq. 11.12.7.2 is the same except that  $A_s$  is in mm<sup>2</sup>,  $V_n$  is in N, and  $f_y$  is in MPa.

Special horizontal shear reinforcement shall be anchored by a standard hook around the extreme wall frame column reinforcing bars.

Vertical shear forces may be considered to be carried by a combination of masonry shear-resisting mechanisms and truss mechanisms involving intermediate column reinforcing bars.

The nominal horizontal shear stress at the beam-*column* intersection shall not exceed the lesser of 350 psi (2.5 MPa) or  $7\sqrt{f'_m}$  (the metric equivalent is  $0.58\sqrt{f'_m}$  MPa).

### **11.13 GLASS-UNIT MASONRY AND MASONRY VENEER:**

**11.13.1 Design Lateral Forces and Displacements:** Glass-unit masonry and masonry veneer shall be designed and detailed to resist the design lateral forces as described in Sec. 6.1 and 6.2.

#### **11.13.2 Glass-Unit Masonry Design:**

**11.13.2.1:** The requirements of Chapter 11 of Ref. 11-1 shall apply to the design of *glass unit masonry*. The out-of-plane seismic strength shall be considered as the same as the strength to resist wind pressure as specified in Sec. 11.3 of Ref. 11-1.

#### **11.13.3 Masonry Veneer Design:**

**11.13.3.1:** The requirements of Chapter 12 of Ref. 11-1 shall apply to the design of *masonry veneer*.

**11.13.3.2:** For *structures* in *Seismic Design Category E*, corrugated sheet metal anchors shall not be used.

## Appendix to Chapter 11

### ALTERNATIVE PROVISIONS FOR THE DESIGN OF MASONRY STRUCTURES

#### 11A.1 GENERAL

**11A.1.1 Scope:** The provisions of this chapter for the design and construction of reinforced and plain (unreinforced) masonry components and systems shall be permitted as an alternative to the provisions of Chapter 11. The seismic design requirements of this appendix chapter apply to the design of masonry and the construction of masonry structural elements, except glass unit masonry and masonry *veneers*, in all *Seismic Design Categories*.

**11A.1.2 Reference Document:** The design, construction, and quality assurance of masonry components designed in accordance with the alternative masonry provisions of this appendix chapter shall conform to the requirements of Ref. 11A-1 except as modified herein:

Ref. 11A-1 *Building Code Requirements for Masonry Structures*, ACI 530-95/ASCE 5-95/TMS 402-95, and *Specification for Masonry Structures*, ACI 530.1-95/ASCE 6-95/TMS 602-95.

#### 11A.1.2.1 Modifications to Chapter 10 of Ref. 11A-1:

**11A.1.2.1.1:** The requirements of Sec. 10.1.1 and 10.2.1 of Ref. 11A-1 shall not apply.

**11A.1.2.1.2:** Masonry *structures* and masonry elements shall comply with the requirements of Sec. 10.2.2 of Ref. 11A-1 with the exception that Sec. 10.2.2.1 shall not apply. In addition, masonry *structures* and masonry elements shall comply with the requirements of Sec. 10.3 through 10.7 of Ref. 11A-1. Requirements for *Seismic Design Categories* A, B, C, D and E as defined in Sec. 1.4.4 shall be the same as requirements for Seismic Performance Categories as described in Chapter 10 of Ref. 11A-1.

**11A.1.2.1.3:** *Required strength* to resist seismic forces in combinations with gravity and other loads shall be as required in Sec. 5.2.7. Nonbearing masonry *walls* shall be designed for the seismic force applied perpendicular to the plane of the *wall* and uniformly distributed over the *wall* area.

**11A.2 RESPONSE MODIFICATION COEFFICIENTS**  
**8A.3 RESPONSE MODIFICATION COEFFICIENTS:** The response modification coefficients,  $R$ , of Table 5.2.2 for *special reinforced masonry shear walls* shall apply, provided masonry is designed in accordance with Chapter 7 and Sec. 10.6 of Ref. 11A-1. The  $R$  coefficients of Table 5.2.2 for *intermediate reinforced masonry shear walls* shall apply for masonry designed in accordance with Chapter 7 and Sec. 10.5 of Ref. 11A-1. The  $R$  coefficients of Table 5.2.2 for *ordinary reinforced masonry shear walls* shall apply for walls designed in accordance with Chapter 7 of Ref. 11A-1. The  $R$  coefficients of Table 5.2.2 for *detailed plain masonry shear walls* shall apply for walls designed in accordance with Chapter 6 and Sec. 10.5 of Ref. 11A-1. The  $R$  coefficients of Table 5.2.2 for *ordinary plain masonry shear walls* shall apply for walls designed in accordance with Chapter 6 of Ref. 11A-1.

## Chapter 12

### WOOD STRUCTURE DESIGN REQUIREMENTS

#### 12.1 GENERAL:

**12.1.1 Scope:** The design and construction of wood *structures* to resist seismic forces and the material used therein shall comply with the requirements of this chapter.

**12.1.2 Reference Documents:** The quality, testing, design, and construction of members and their fastenings in wood systems that resist seismic forces shall conform to the requirements of the reference documents listed in this section except as modified by the provisions of this chapter.

##### 12.1.2.1 Engineered Wood Construction:

Ref. 12-1	<i>Load and Resistance Factor Standard for Engineered Wood Construction, including supplements</i>	ASCE 16-95 (1995)
Ref. 12-2	<i>Plywood Design Specifications</i>	APA (1995)
Ref. 12-3	<i>Design Capacities of APA Performance-Rated Structural-Use Panels</i>	APA N375B (1995)
Ref. 12-4	<i>Diaphragms, Research Report 138</i>	APA (1991)

##### 12.1.2.2 Conventional Light-Frame Construction:

Ref. 12-5	<i>One- and Two-Family Dwelling Code</i>	Council of American Building Officials (CABO) (1995)
Ref.12-6	<i>Span Tables for Joists and Rafters</i>	NFoPA T903 (1992)

##### 12.1.2.3 Materials Standards:

Ref. 12-7	<i>American Softwood Lumber Standard</i>	PS 20-94 (1994)
Ref. 12-8	<i>American National Standard for Wood Products-- Structural Glued Laminated Timber</i>	ANSI/AITC A190.1 (1992)
Ref. 12-9	<i>Standard Specification for Establishing and Monitoring Structural Capacities of Prefabricated Wood I-Joists</i>	ASTM D5055-95A (1995)

Ref. 12-10	<i>Softwood Plywood--Construction and Industrial</i>	PS 1-95 (1995)
Ref. 12-11	<i>Performance Standard for Wood-Based Structural-Use Panels</i>	PS2-92 (1992)
Ref. 12-12	<i>Wood Poles</i>	ANSI 05.1 (1992)
Ref. 12-13	<i>Wood Particleboard</i>	ANSI A208.1 (1993)
Ref. 12-14	<i>Preservative Treatment by Pressure Process</i>	AWPA C1(1991), C2 and C3 (1991), C9 (1990), and C28 (1991)

Dimensions for wood products and associated products designated in this section are nominal dimensions and actual dimensions shall be not less than prescribed by the reference standards.

### 12.1.3 Notations:

$D$  = Reference resistance.

$D'$  = Adjusted resistance.

$h$  = The height of a shear wall measured as:

1. The maximum clear height from the foundation to the bottom of the floor or roof framing above or
2. The maximum clear height from the top of the floor or roof framing to the bottom of the floor or roof framing above.

$l$  = The dimension of a diaphragm perpendicular to the direction of application of force. For open-front *structures*,  $l$  is the length from the edge of the diaphragm at the open front to the vertical resisting elements parallel to the direction of the applied force. For a cantilevered diaphragm,  $l$  is the length of the cantilever.

$w$  = The dimension of a diaphragm or shear wall in the direction of application of force.

$\lambda$  = Time effect factor.

$\phi$  = Resistance factor.

$\lambda\phi D$  = Factored resistance.

**12.2 DESIGN METHODS:** Design of wood *structures* to resist seismic forces shall be by one of the methods described in Sec. 12.2.1 and 12.2.2:

**12.2.1 Engineered Wood Design:** Engineered design of wood *structures* shall use load and resistance factor design (LRFD) and shall be in accordance with this chapter and the reference documents specified in Sec. 12.1.2.1.

**12.2.2 Conventional Light-Frame Construction:** Where permitted by Sec. 12.7 and 12.8, wood *structures* shall be permitted to be constructed in accordance with the provisions of Sec. 12.5.



**12.2.2.1** When a *structure* of otherwise conventional construction contains structural elements not conforming to Sec. 12.5, those elements shall be designed in accordance with Sec. 12.2.1 and force resistance and stiffness shall be maintained.

### **12.3 ENGINEERED WOOD CONSTRUCTION:**

**12.3.1 General:** The proportioning, design, and detailing of engineered wood systems, members, and connections shall be in accordance with the reference documents, except as modified by this section.

**12.3.2 Framing Requirements:** All wood columns and posts shall be framed to provide full end bearing. Alternatively, column and post end connections shall be designed to resist the full compressive loads, neglecting all end bearing capacity. Column and post end connections shall be fastened to resist lateral and net induced uplift forces.

**12.3.3 Deformation Compatibility Requirements:** Deformation compatibility of connections within and between structural elements shall be considered in design such that the deformation of each element and connection comprising the *seismic-force-resisting system* is compatible with the deformations of the other seismic-force-resisting elements and connections and with the overall system. See Sec. 5.2.8 for story drift limitations.

### **12.3.4 Design Limitations:**

**12.3.4.1 Wood Members Resisting Horizontal Seismic Forces Contributed by Masonry and Concrete:** Wood *shear walls*, *diaphragms*, horizontal trusses and other members shall not be used to resist horizontal seismic forces contributed by masonry or concrete construction in *structures* over one story in height.

#### **Exceptions:**

1. Wood floor and roof members shall be permitted to be used in horizontal trusses and *diaphragms* to resist horizontal seismic forces (including those due to masonry veneer, fireplaces, and chimneys) provided such forces do not result in *torsional force distribution* through the truss or *diaphragm*.
2. Vertical wood *structural-use panel* sheathed *shear walls* shall be permitted to be used to provide resistance to seismic forces in two-story *structures* of masonry or concrete construction, provided the following requirements are met:
  - a. Story-to-story wall heights shall not exceed 12 feet (3660 mm).
  - b. *Diaphragms* shall not be considered to transmit lateral forces by *torsional force distribution* or cantilever past the outermost supporting *shear wall*.
  - c. Combined deflections of *diaphragms* and *shear walls* shall not permit per story drift of supported masonry or concrete walls to exceed the limits of Table 5.2.8.
  - d. Wood *structural-use panel* sheathing in *diaphragms* shall have all unsupported edges blocked. Wood *structural-use panel* sheathing for both stories of *shear walls* shall have all unsupported edges blocked and, for the lower story, shall have a minimum thickness of 15/32 inch (12 mm).

- e. There shall be no out-of-plane horizontal offsets between the first and second stories of wood *structural-use panel shear walls*.

**12.3.4.2 Horizontal Distribution of Shear:** *Diaphragms* shall be defined as flexible for the purposes of distribution of story shear and torsional moment when the maximum lateral deformation of the *diaphragm* is more than two times the average story drift of the associated story determined by comparing the computed maximum in-plane deflection of the *diaphragm* itself under lateral load with the story drift of adjoining vertical-resisting elements under equivalent tributary lateral load. Other *diaphragms* shall be defined as rigid. Design of *structures* with rigid *diaphragms* shall include the *structure* configuration requirements of Sec. 5.2.3.1 and the horizontal shear distribution requirements of Sec. 5.3.5.

Open front *structures* with rigid wood *diaphragms* resulting in *torsional force distribution* shall be permitted provided the *length*,  $l$ , of the *diaphragm* normal to the open side does not exceed 25 feet (7620 mm), the *diaphragm* sheathing conforms to Sec. 12.4.3.1 through 12.4.3.4, and the  $l/w$  ratio (as shown in Figure 12.3.4.2-1) is less than 1/1 for one-story *structures* or 1/1.5 for *structures* over one story in height.

**Exception:** Where calculations show that *diaphragm* deflections can be tolerated, the *length*,  $l$ , normal to the open end shall be permitted to be increased to a  $l/w$  ratio not greater than 1.5/1 when sheathed in conformance with Sec. 12.4.3.1 or 12.4.3.4, or to 1/1 when sheathed in conformance with Sec. 12.4.3.3.

Rigid wood *diaphragms* shall be permitted to cantilever past the outermost supporting *shear wall* (or other vertical resisting element) a *length*,  $l$ , of not more than 25 feet (7620 mm) or two thirds of the *diaphragm width*,  $w$ , whichever is the smaller. Figure 12.3.4.2-2 illustrates the dimensions of  $l$  and  $w$  for a cantilevered *diaphragm*.

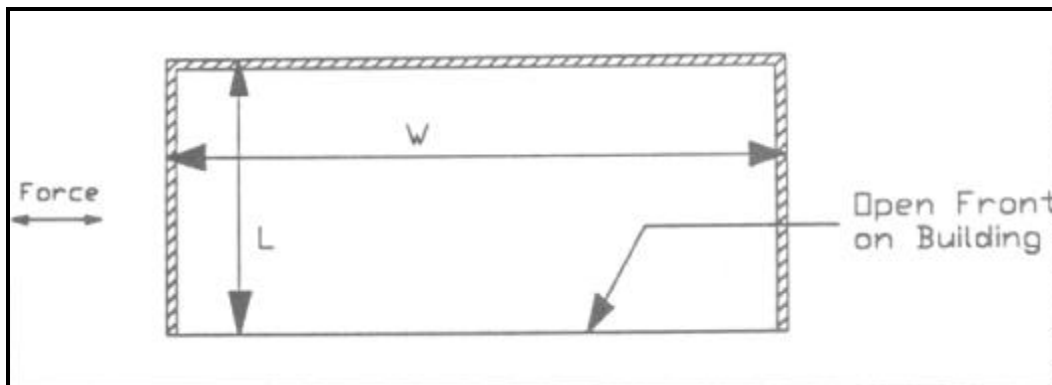

FIGURE 12.3.4.2-1 Diaphragm length and width for plan view of open front building.

*Structures* with rigid wood *diaphragms* having a torsional irregularity in accordance with Table 5.2.3.2, Item 1, shall meet the following requirements: The  $l/w$  ratio shall not exceed 1/1 for one-story *structures* or 1/1.5 for *structures* greater than one story in height, where  $l$  is the dimension parallel to the load direction for which the irregularity exists.

**Exception:** Where calculations demonstrate that the *diaphragm* deflections can be tolerated, the width is permitted to be increased and the  $l/w$  ratio may be increased to 1.5/1 when

sheathed in conformance with Sec. 12.4.3.1 or to 1/1 when sheathed in conformance with Sec. 12.4.3.3 or 12.4.3.4.

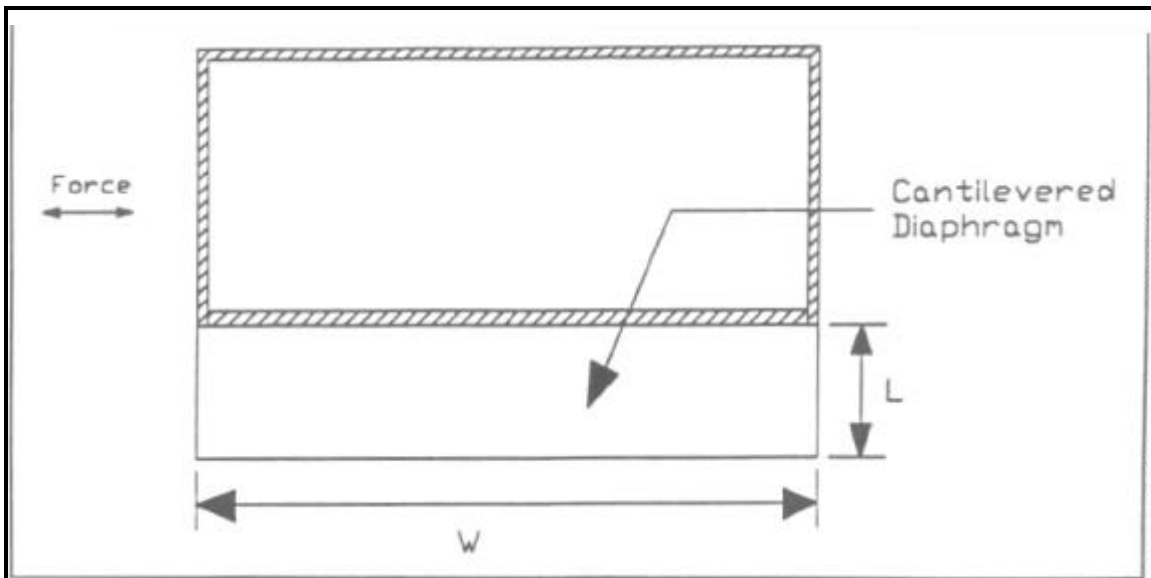

FIGURE 12.3.4.2-2 Diaphragm length and width for plan view of cantilevered diaphragm.

**12.3.4.3 Framing and Anchorage Limitations:** All framing used for *shear wall* construction shall conform to Ref. 12-7 for 2-by (actual 1.5 in., 38 mm) or larger members. *Boundary elements* shall be tied together at all corners by lapping the members and nailing with 2-16d (0.162 by 2½ in., 4 by 64 mm) common nails or an equivalent capacity connection. *Diaphragm* and *shear wall* sheathing shall not be used to splice *boundary elements*. *Diaphragm chords* and *drag struts* shall be placed in, or tangent to, the plane of the *diaphragm* framing unless it can be demonstrated that the moments, shears, and deflections and deformations, considering eccentricities resulting from other configurations, can be tolerated without exceeding the adjusted resistance and drift limits.

**12.3.4.4 Shear Wall Anchorage:** Where net uplift is induced, tie-down (hold-down) devices shall be used. Tie-down (hold-down) devices attached to the end post with nails are permitted. All devices shall only be used where the uplift resistance values are based on cyclic testing of wall assemblies and the test results indicate that the tie-down device does not reduce the stiffness, ductility, or capacity of the *shear wall* when compared to nailed-on devices.

Foundation anchor bolts shall have a plate washer under each nut. The minimum plate washer sizes are as follows:

Bolt size	Plate washer size for shear walls
1/2 and 5/8 inch (13 and 16 mm)	1/4 x 3 x 3 inch (6 x 75 x 75 mm)
3/4, 7/8, and 1 inch (19, 22, and 25 mm)	3/8 x 3 x 3 inch (10 x 75x 75 mm)

Hole diameters in the plate washer 3/16 in. (5 mm) larger than the bolt diameter are permitted provided that a standard cut washer is placed between the plate washer and the nut. Foundation anchor bolt embedment shall conform to the requirements of Chapters 6 and 8.

Bolts shall be placed a maximum of 2 inches (50 mm) from the sheathed side of walls sheathed on one face. Walls sheathed on both faces shall have the bolts staggered with the bolt a maximum of 2 in. (50 mm) from either side of the wall. Alternatively, for walls sheathed on both faces the bolts shall be placed at the center of the foundation sill with the edge of the plate washer within 1/2 in. (13 mm) of each face of the wall. The plate washer width shall be a minimum of 3 in (75 mm) and the plate thickness shall be determined by analysis using the upward force on the plate equal to the tension capacity of the bolt.

Anchor bolt and tie-down nuts shall be tightened without crushing the wood, and provision for preventing nuts from loosening shall be made just prior to covering the framing.

## **12.4 DIAPHRAGMS AND SHEAR WALLS:**

**12.4.1 Diaphragm and Shear Wall Aspect Ratios:** The aspect ratio  $l/w$  of a *diaphragm* and  $h/w$  of a *shear wall* shall not be more than permitted in Sec. 12.4.3.1 through 12.4.3.4. See Sec. 12.1.3 for definitions of  $l$ ,  $w$ , and  $h$ .

Alternately, where *structural-use panel shear walls* with openings are designed for force transfer around the openings, the aspect ratio,  $h/w$ , limitations of Sec. 12.4.3.1 shall apply to the overall *shear wall* including openings and to each wall pier at the side of an opening. The height of a wall pier shall be defined as the clear height of the pier at the side of an opening. The width of a wall pier shall be defined as the sheathed width of the pier. Design and detailing of *boundary elements* around the opening shall be provided in accordance with Sec. 12.2.1 of Ref. 12-1. The width of a wall pier shall not be less than 2 feet (610 mm).

**12.4.2 Shear Resistance Based on Principles of Mechanics:** Shear resistance of *diaphragms* and *shear walls* shall be permitted to be calculated by principles of mechanics using values of fastener strength and sheathing shear resistance, provided fastener resistance in the sheathing material is based on approved values developed from cyclical tests.

**12.4.3 Sheathing Requirements:** Sheathing in *diaphragms* and *shear walls* shall conform to the requirements in this section. All panel sheathing joints in *shear walls* shall occur over studs or blocking. Where *diaphragms* are designated as blocked in Tables 12.4.3-1a and b, all joints in sheathing shall occur over framing members of the width prescribed in the table. Fasteners shall be placed at least 3/8 in. (10 mm) from ends and edges of boards and sheets. It is advised that the edge distance be increased where possible to reduce the potential for splitting of the framing and nail pull through in the sheathing. Sheathing nails or other approved sheathing connectors shall be driven flush with the surface of the sheathing.

The shear values for shear panels of different materials applied to the same wall line are not cumulative. The shear values for the same material applied to both faces of the same wall are cumulative. Adhesive attachment of *shear wall* sheathing is not permitted.

For *diaphragms* and *shear walls*, the acceptable types of panel sheathing listed in Sec. 12.4.3.1 shall have nominal sheet sizes of 4 ft by 8 ft (1200 mm by 2400 mm) or larger. Sheet type sheathing shall be

arranged so that the width of a sheet in a *diaphragm* or *shear wall* shall not be less than 2 feet (600 mm).

**Exception:** For shear walls with panel sheathing attached with the long direction on the panels perpendicular to the studs, a single sheathing panel with a minimum vertical dimensions of 1 foot (300 mm) and a minimum horizontal dimension of 4 feet (1200 mm) is permitted to be used if it is located at mid-height of the wall, and is fully blocked and nailed.

**12.4.3.1 Structural-Use Panel Sheathing:** *Diaphragms* and *shear walls* sheathed with *structural-use panel* sheets shall be permitted to be used to resist seismic forces based on the factored shear resistance ( $\lambda\phi D$ ) set forth in Tables 12.4.3-1a and b for *diaphragms* and Tables 12.4.3-2a and b for *shear walls*.

The size and spacing of fasteners at *structural-use panel* sheathing boundaries, *structural-use panel* sheet edges, and intermediate supports shall be as given in Tables 12.4.3-1a and b and 12.4.3-2a and b. The  $l/w$  ratio shall not exceed 4/1 for *blocked diaphragms* or 3/1 for unblocked *diaphragms*, and the  $h/w$  ratio shall not exceed 2/1 for *shear walls*.

Where *structural-use panel* sheathing is used as the exposed finish on the exterior of outside walls, it shall have an exterior exposure durability classification. Where *structural-use panel* sheathing is used on the exterior of outside walls but not as the exposed finish, it shall be of a type manufactured with exterior glue. Where *structural-use panel* sheathing is used elsewhere, it shall be of a type manufactured with intermediate or exterior glue.

**12.4.3.2 Other Panel Sheathing Materials:** Panel materials other than *structural-use panel* sheathing have no recognized capacity for seismic-force resistance and are not permitted as part of the seismic-force-resisting system except in conventional light-frame construction, Sec. 12.5.

**12.4.3.3 Single Diagonally Sheathed Lumber Diaphragms and Shear Walls:** Single diagonally sheathed lumber *diaphragms* and *shear walls* shall consist of 1-by (actual  $\frac{3}{4}$  in., 19 mm) sheathing boards laid at an angle of approximately 45 degrees (0.8 rad) to supports. Common nails at each intermediate support shall be two 8d (0.131 x  $2\frac{1}{2}$  in., 3 x 64 mm) for 1 by 6 (actual  $\frac{3}{4}$  in. by  $5\frac{1}{2}$  in., 19 mm by 140 mm) and three 8d (0.131 x  $2\frac{1}{2}$  in., 3 x 64 mm) for 1 by 8 (actual  $\frac{3}{4}$  in. by  $7\frac{1}{2}$  in., 19 mm by 190 mm) boards. One additional nail shall be provided in each board at *diaphragm* and *shear wall* boundaries. For box nails of the same penny weight, one additional nail shall be provided in each board at each intermediate support and two additional nails shall be provided in each board at *diaphragm* and *shear wall* boundaries. End joints in adjacent boards shall be separated by at least one framing space between supports. Single diagonally sheathed lumber *diaphragms* and *shear walls* shall be permitted to consist of 2-by (actual  $1\frac{1}{2}$  in., 38 mm) sheathing boards where 16d (0.131 by  $2\frac{1}{2}$  in., 3 by 64 mm) nails are substituted for 8d (0.131 by  $2\frac{1}{2}$  in., 3 x 64 mm) nails, end joints are located as above, and the support is not less than 3 in. (actual  $2\frac{1}{2}$  in., 64 mm) width or 4 in. (actual  $3\frac{1}{2}$  in., 89 mm) depth.

The factored shear resistance ( $\lambda\phi D$ ), for these panels is 220 plf (3.2 kN/m). The  $l/w$  ratio shall not be more than 3/1 for *diaphragms* and the  $h/w$  ratio shall not be more than 2/1 for *shear walls*.

**12.4.3.4 Double Diagonally Sheathed Lumber Diaphragms and Shear Walls:** Double diagonally sheathed lumber *diaphragms* and *shear walls* shall conform to the requirements for single diagonally sheathed lumber *diaphragms* and *shear walls* and the requirements of this section.

Double diagonally sheathed lumber *diaphragms* and *shear walls* shall be sheathed with two layers of diagonal boards placed perpendicular to each other on the same face of the supports. Each *chord* shall be designed for the axial force induced and for flexure between supports due to a uniform load equal to 50 percent of the shear per foot in the *diaphragm* or *shear wall*. The factored shear resistance ( $\lambda\phi D$ ) for these panels is 660 plf (9.6 kN/m). The  $l/w$  ratio shall not be more than 3/1 and the  $h/w$  ratio shall not be more than 2/1.

## **12.5 CONVENTIONAL LIGHT-FRAME CONSTRUCTION:**

**12.5.1 Scope:** Conventional light-frame construction is a system constructed entirely of repetitive horizontal and vertical wood light-framing members selected from tables in Ref. 12-6 and conforming to the framing and bracing requirements of Ref. 12-5 except as modified by the provisions in this section. *Structures* with concrete or masonry walls above the basement *story* shall not be considered to be conventional light-frame construction. Construction with concrete and masonry basement walls shall be in accordance with Ref. 12-5 or equivalent. Conventional light-frame construction is limited to *structures* with bearing wall heights not exceeding 10 feet (3 m) and the number of stories prescribed in Table 12.5.1-1. The gravity dead load of the construction is limited to 15 psf (720 Pa) for roofs and exterior walls and 10 psf (480 Pa) for floors and partitions and the gravity live load is limited to 40 psf (1915 Pa).

**Exceptions:** Masonry veneer is acceptable for:

1. The first *story above grade*, or the first two stories above grade when the lowest story has concrete or masonry walls, of *Seismic Design Category B and C structures*.
2. The first two stories above grade, or the first three stories above grade when the lowest story has concrete or masonry walls, of *Seismic Design Category B structures*, provided structural use panel wall bracing is used and the length of bracing provided is 1.5 times the length required by Table 12.5.2-1.

The requirements of this section are based on platform construction. Other framing systems must have equivalent detailing to ensure force transfer, continuity, and compatible deformation.

When a *structure* of otherwise conventional light-frame construction contains structural elements not conforming to Sec. 12.5, those elements shall have an engineered design to resist the forces specified in Chapter 2 in accordance with Sec. 12.2.2.1.

**12.5.1.1 Irregular Structures:** Irregular *structures* in *Seismic Design Categories C and D* of conventional light-frame construction shall have an engineered *lateral-force-resisting system* designed to resist the forces specified in Chapter 2 in accordance with Sec. 12.2.1. A *structure* shall be considered to have an irregularity when one or more of the conditions described in Sec. 12.5.1.1.1 to 12.5.1.1.7 are present.

**12.5.1.1.1** A *structure* shall be considered to have an irregularity when exterior *braced wall panels* are not in one plane vertically from the foundation to the uppermost *story* in which they are required. See Figure 12.5.1.1.1-1.

**Exceptions:** Floors with cantilevers or setbacks not exceeding four times the nominal depth of the floor joists (see Figure 12.5.1.1.1-2) are permitted to support *braced wall panels* provided:

1. Floor joists are 2 in. by 10 in. (actual 1½ by 9¼ in., 38 by 235 mm) or larger and spaced not more than 16 inches (405 mm) on center.
2. The ratio of the back span to the cantilever is at least 2 to 1.
3. Floor joists at ends of *braced wall panels* are doubled.
4. A continuous rim joist is connected to the ends of all cantilevered joists. The rim joist shall be permitted to be spliced using a metal tie not less than 0.058 inch (2 mm) (16 galvanized gage) and 1½ inches (38 mm) wide fastened with six 16d (0.162 by 3½ in, 4 by 89 mm) common nails on each side. Steel used shall have a minimum yield of 33,000 psi (228 MPa) such as ASTM 653 Grade 330 structural quality or ASTM A446 Grade A galvanized steel.
5. Gravity loads carried by joists at setbacks or the end of cantilevered joists are limited to single *story* uniform wall and roof loads and the reactions from headers having a span of 8 feet (2440 mm) or less.

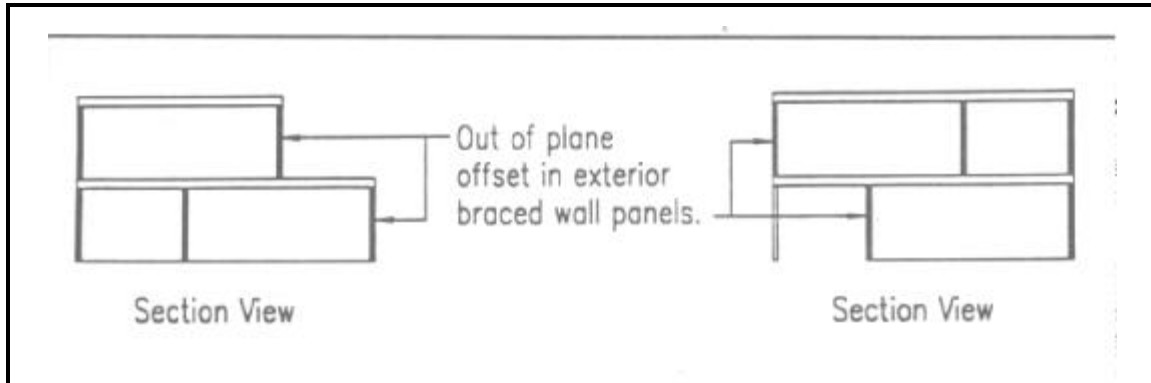

FIGURE 12.5.1.1.1-1 Out-of-plane exterior walls irregularity.

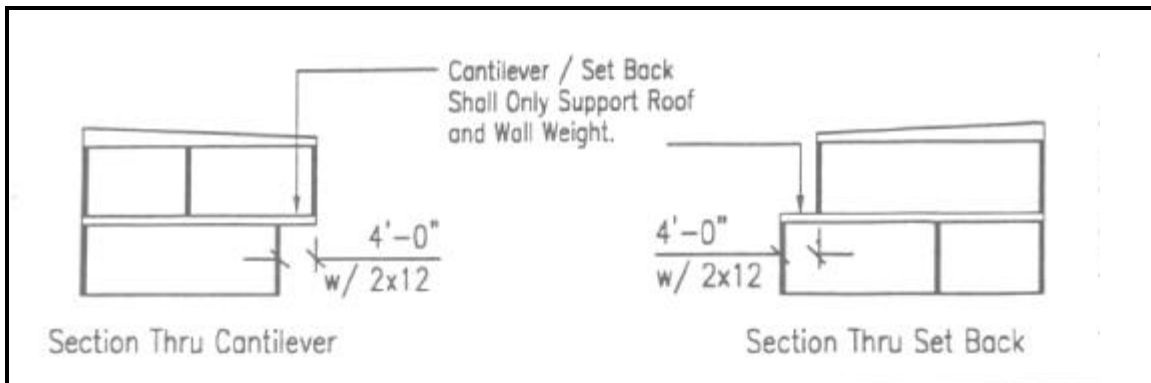
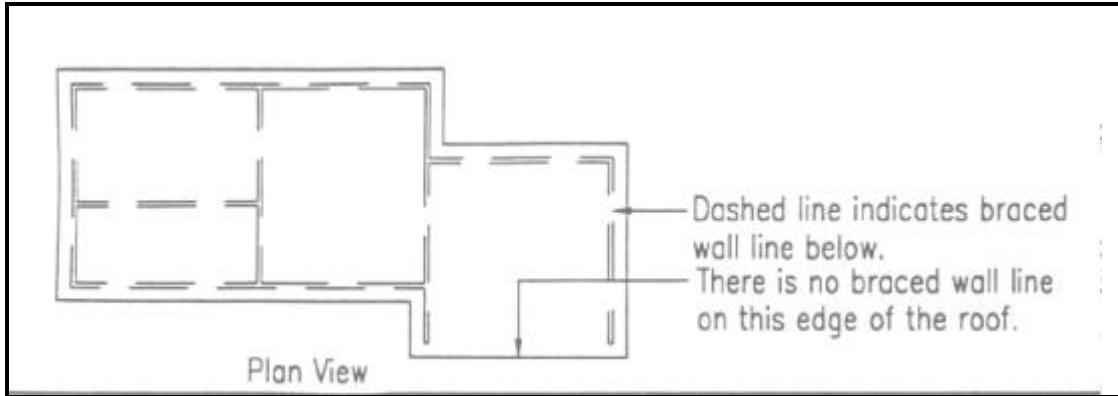

FIGURE 12.5.1.1.1-2 Cantilever/setback irregularity for exterior walls.

**12.5.1.1.2** A *structure* shall be considered to have an irregularity when a section of floor or roof is not laterally supported by *braced wall lines* on all edges. See Figure 12.5.1.1.2-1.

**Exception:** Portions of roofs or floors that support *braced wall panels* above shall be permitted to extend up to 6 feet (1830 mm) beyond a *braced wall line*. See Figure 12.5.1.1.2-2.



**FIGURE 12.5.1.1.2-1** Unsupported diaphragm irregularity.

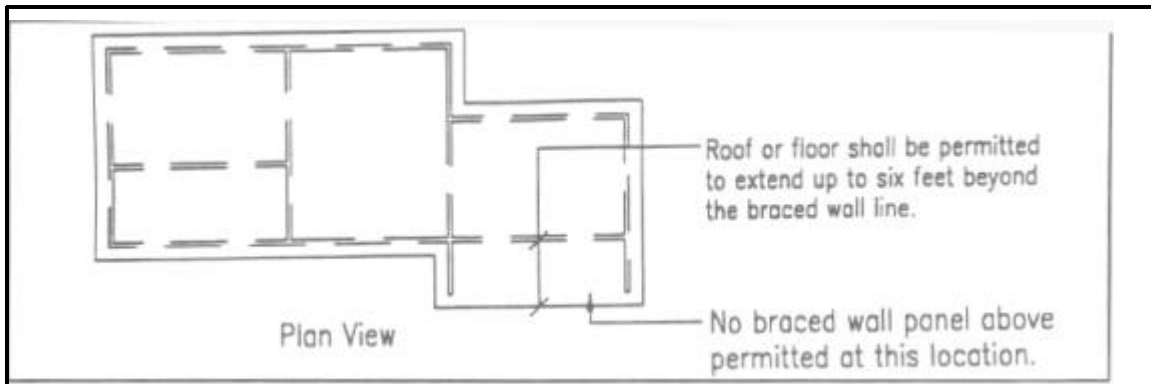
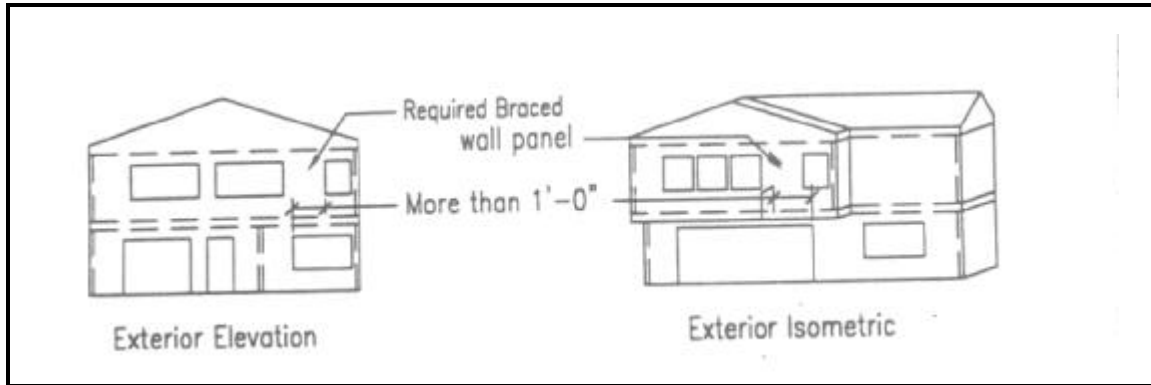

**FIGURE 12.5.1.1.2-2** Allowable cantilevered diaphragm.

**12.5.1.1.3** A *structure* shall be considered to have an irregularity when the end of a required *braced wall panel* extends more than 1 foot (305 mm) over an opening in the wall below. This requirement is applicable to *braced wall panels* offset in plane and to *braced wall panels* offset out of plane as permitted by the exception to Sec. 12.5.1.1.1. See Figure 12.5.1.1.3.

**Exception:** *Braced wall panels* shall be permitted to extend over an opening not more than 8 feet (2440 mm) in width when the header is a 4-inch by 12-inch (actual 3½ by 11¼ in., 89 by 286 mm) or larger member.

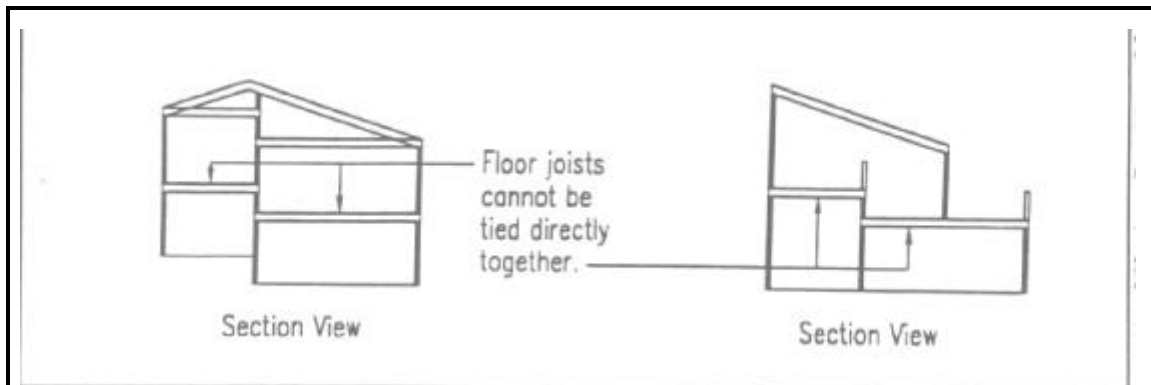



**FIGURE 12.5.1.1.3** Opening in wall below irregularity.

**12.5.1.1.4** A *structure* shall be considered to have an irregularity when portions of a floor level are vertically offset such that the framing members on either side of the offset cannot be lapped or tied together in an approved manner. See Figure 12.5.1.1.4.

**Exception:** Framing supported directly by foundations.



**FIGURE 12.5.1.1.4** Vertical offset irregularity.

**12.5.1.1.5** A *structure* shall be considered to have an irregularity when *braced wall lines* are not perpendicular to each other. See Figure 12.5.1.1.5

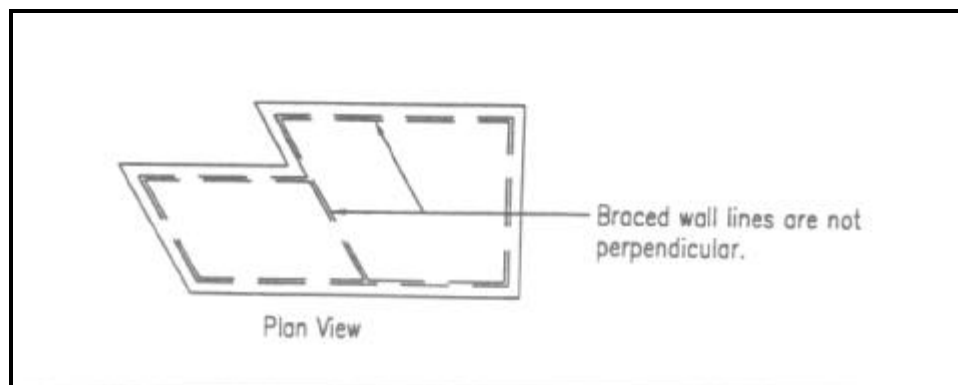

**FIGURE 12.5.1.1.5** Nonperpendicular wall irregularity.

**12.5.1.1.6 Diaphragm Openings:** A structure shall be considered to have an irregularity when openings in floor and roof *diaphragms* having a maximum dimension greater than 50 percent of the distance between lines of bracing or an area greater than 25 percent of the area between orthogonal pairs of *braced wall lines* are present. See Figure 12.5.1.1.6.

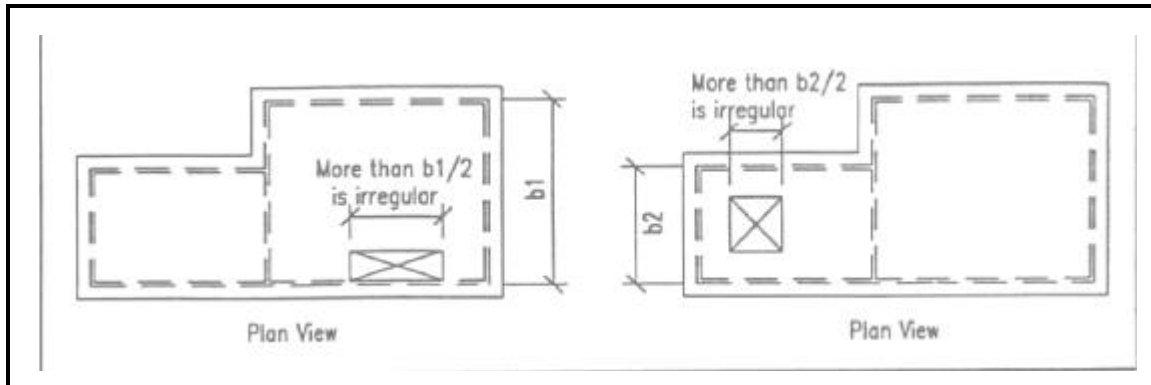

FIGURE 12.5.1.1.6 Diaphragm opening irregularity.

**12.5.1.1.7 Stepped Foundation:** A structure shall be considered to have an irregularity when the shear walls of a single story vary in height more than 6 feet (1800 mm).

**12.5.2 Braced Walls:** The following are the minimum braced wall requirements.

**12.5.2.1 Spacing Between Braced Wall Lines:** Interior and exterior *braced wall lines* shall be located at the spacing indicated in Table 12.5.1-1.

**12.5.2.2 Braced Wall Line Sheathing Requirements:** All *braced wall lines* shall be braced by one of the types of sheathing prescribed in Table 12.5.2-1. The required sum of lengths of *braced wall panels* at each *braced wall line* is prescribed in Table 12.5.2-1. *Braced wall panels* shall be distributed along the length of the *braced wall line* with sheathing placed at each end of the wall or partition or as near thereto as possible. To be considered effective as bracing, each *braced wall panel* shall conform to Sec. 602.9 of Ref. 12-5. All panel sheathing joints shall occur over studs or blocking. Sheathing shall be fastened to all studs and top and bottom plates and at panel edges occurring over blocking. All wall framing to which sheathing used for bracing is applied shall be 2-by (actual 1½ inch, 38 mm) or larger members.

*Cripple walls* shall be braced as required for *braced wall lines* and shall be considered an additional story. Where interior post and girder framing is used, the capacity of the *braced wall panels* at exterior *cripple walls* shall be increased to compensate for length of interior braced wall eliminated by increasing the length of the sheathing or increasing the number of fasteners.

**12.5.2.3 Attachment:**

**12.5.2.3.1** Nailing of *braced wall panel* sheathing shall be not less than the minimum included in Tables 12.4.3-2a and b or as prescribed in Table 12.5.2-1.

**12.5.2.3.2** Nailing for diagonal boards shall be as prescribed in Sec. 12.4.3.3 and 12.4.3.4.

**12.5.2.3.3** Adhesive attachment of wall sheathing is not permitted.

**12.5.3 Detailing Requirements:** The following requirements for framing and connection details shall apply as a minimum.

**12.5.3.1 Wall Anchorage:** Anchorage of *braced wall line* sills to concrete or masonry foundations shall be provided. Such anchorage shall conform to the requirements in Figure 403.1a of Sec. 403 of Ref 12-5, except that such anchors shall be spaced at not more than 4 ft. (1220 mm) on center for *structures* over two stories in height. For *Seismic Design Categories C, D, and E*, plate washers, a minimum of ¼ inch by 3 inches by 3 inches in size, shall be provided between the foundation sill plate and the nut. Other anchorage devices having equivalent capacity shall be permitted.

**12.5.3.2 Top Plates:** Stud walls shall be capped with double-top plates installed to provide overlapping at corners and intersections. End joints in double-top plates shall be offset at least 4 feet (1220 mm). Single top plates shall be permitted to be used when they are spliced by framing devices providing capacity equivalent to the lapped splice prescribed for double top plates.

**12.5.3.3 Bottom Plates:** Stud walls shall have full bearing on a 2-by (actual 1½ in., 38 mm) or larger plate or sill having a width at least equal to the width of the studs.

**12.5.3.4 Braced Wall Panel Connections:** Accommodations shall be made to transfer forces from roofs and floors to *braced wall panels* and from the *braced wall panels* in upper stories to the *braced wall panels* in the *story* below. Where platform framing is used, such transfer at *braced wall panels* shall be accomplished in accordance with the following:

1. All *braced wall panel* top and bottom plates shall be fastened to joists, rafters or full depth blocking. *Braced wall panels* shall be extended and fastened to roof framing at intervals not to exceed 50 feet (15.2 m).

**Exception:** Where roof trusses are used, provisions shall be made to transfer lateral forces from the roof diaphragm to the braced wall.

2. Bottom plate fastening to joist or blocking below shall be with not less than 3-16d (0.162 by 3½ in., 4 by 89 mm) nails at sixteen inches on center.
3. Blocking shall be nailed to the top plate below with not less than 3-8d (0.131 by 2½ in., 3 by 64 mm) toenails per block.
4. Joists parallel to the top plates shall be nailed to the top plate with not less than 8d (0.131 by 2½ in., 3 by 64 mm) toenails at 6 in. (150 mm) on center.

In addition, top plate laps shall be nailed with not less than 8-16d (0.162 by 3½ in., 4 by 89 mm) face nails on each side.

**12.5.3.5 Foundations Supporting Braced Wall Panels:** For *structures* with maximum plan dimensions not over 50 ft (15.2 m) foundations supporting *braced wall panels* are required at exterior walls only. *Structures* with plan dimensions greater than 50 ft (15.2 m) shall, in addition, have foundations supporting all required interior *braced wall panels*. Foundation to braced wall connections shall be made at every foundation supporting a *braced wall panel*. The connections shall be distributed along the length of the *braced wall line*. Where all-wood foundations are used, the force transfer shall be determined based on calculation and shall have capacity greater than or equal to the connections required by Sec. 12.5.3.1.

**12.5.3.6 Stepped Footings:** Where the height of a required *braced wall panel* extending from foundation to floor above varies more than 4 ft. (1.2 m) (see Figure 12.5.3.6), the following construction shall be used:

- Where only the bottom of the footing is stepped and the lowest floor framing rests directly on a sill bolted to the footings, the requirements of Sec. 12.5.3.1 shall apply.
- Where the lowest floor framing rests directly on a sill bolted to a footing not less than eight feet (2440 mm) in length along a line of bracing, the line shall be considered to be braced. The double plate of the cripple stud wall beyond the segment of footing extending to the lowest framed floor shall be spliced to the sill plate with metal ties, one on each side of the sill and plate not less than 0.058 inch (16 gage, 2mm) by 1.5 inches (38 mm) wide by 4.8 inches (122 mm) with eight 16d (0.162 by 3.5 inches, 4 by 89 mm) common nails on each side of the splice location (see Figure 12.5.3.6). Steel used shall have a minimum yield of 33,000 psi (228 MPa) such as ASTM 653 Grade 330 structural quality or ASTM A446 Grade A galvanized steel.
- Where *cripple walls* occur between the top of the footing and the lowest floor framing, the bracing requirements for a *story* shall apply.

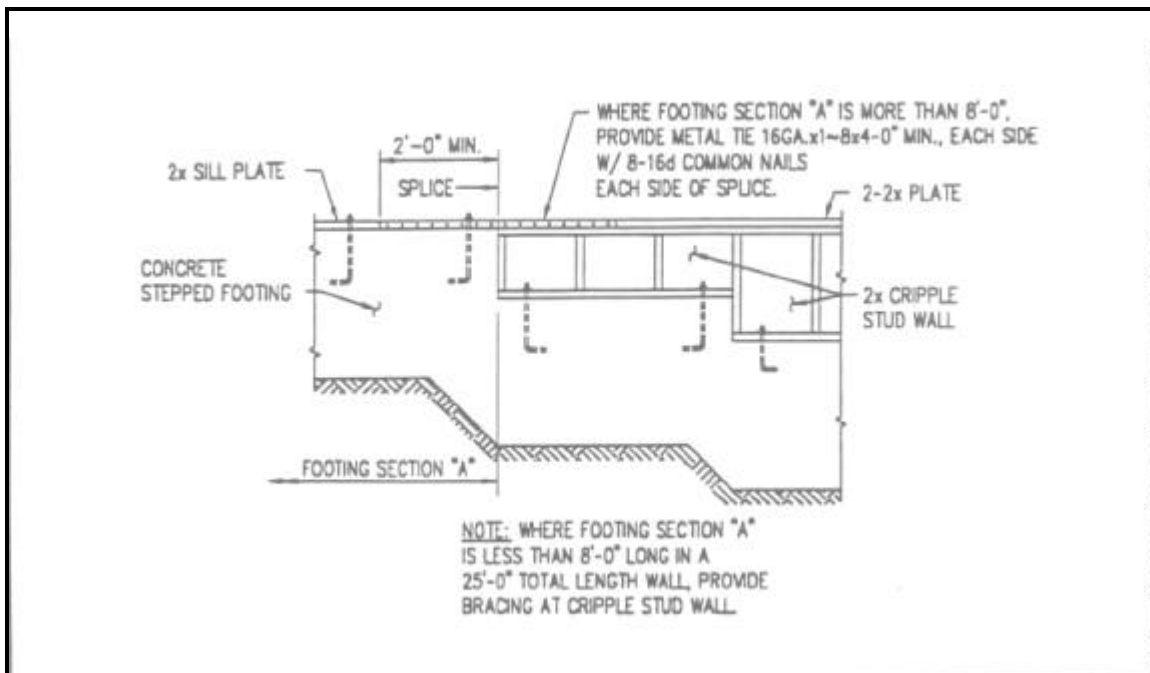

**FIGURE 12.5.3.6 Stepped footing detail.**

**12.5.3.7 Detailing for Openings in Diaphragms:** For Openings with a dimension greater than 4 ft. (1220 mm), or openings in *structures* in *Seismic Design Categories* D and E, the following minimum detail shall be provided. Blocking shall be provided beyond headers and metal ties not less than 0.058 inch (16 gage, 2mm) by 1.5 inches (38 mm) wide by 4.8 inches (122 mm) with eight 16d (0.162 by 3.5 inches, 4 by 89 mm) common nails on each side of the header-joist intersection (see Figure 12.5.3.7). Steel used shall have a minimum yield of 33,000 psi (228 MPa) such as ASTM 653 Grade 330 structural quality or ASTM A446 Grade A galvanized steel.

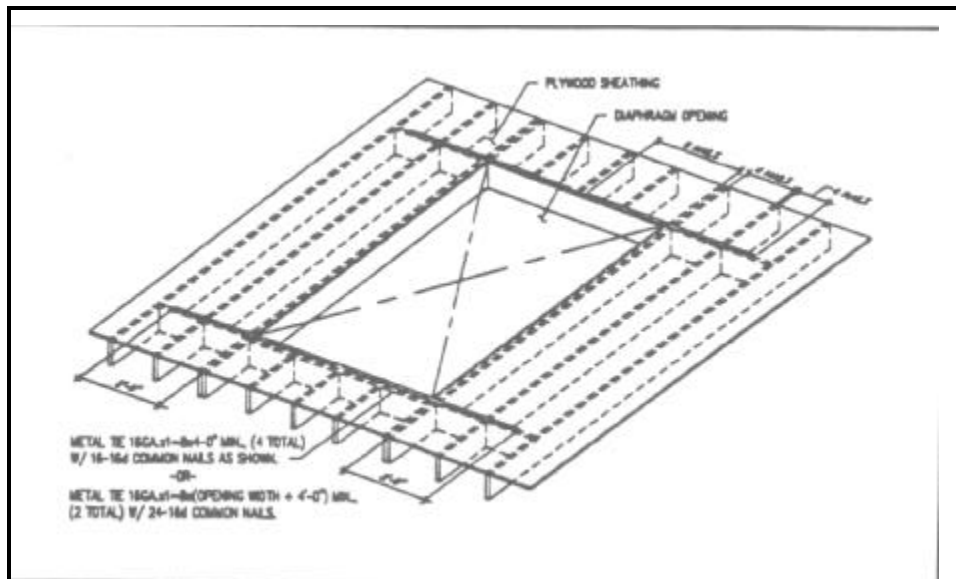

FIGURE 12.5.3.6 Detail for diaphragm opening.

**12.6 SEISMIC DESIGN CATEGORY A:** *Structures* assigned to *Seismic Design Category* A are permitted to be designed and constructed using any applicable materials and procedures permitted in the reference documents and, in addition, shall conform to the requirements of Sec. 5.2.6.1.2. *Structures* constructed in compliance with Sec. 12.5 are deemed to comply with Sec. 5.2.6.1.2.

**Exceptions:**

1. Where Sec. 1.2.1, Exception 1 is applicable, one- and two-family detached dwellings are exempt from the requirements of these *Provisions*.
2. Where Sec. 1.2.1, Exception 2 is applicable, one- and two-family dwellings that are designed and constructed in accordance with the conventional construction requirements of Sec. 12.5 are exempt from other requirements of these *Provisions*.

**12.7 SEISMIC DESIGN CATEGORIES B, C, AND D:** *Structures* assigned to *Seismic Design Categories* B, C, and D shall conform to the requirements of this section, and Sec. 5.2.6.1.2.

**Exceptions:**

1. Where Sec. 1.2.1, Exception 1 is applicable, one- and two-family detached dwellings are exempt from the requirements of these *Provisions*.

2. Where Sec. 12.2.1, Exception 2 is applicable, one- and two-family dwellings that are designed and constructed in accordance with the conventional construction requirements of Sec. 12.5 are exempt from other requirements of these *Provisions*.

**12.7.1 Conventional Light-Frame Construction:** Conventional light-frame construction shall meet the requirements of Sec. 12.5. Alternatively, such *structures* shall meet the requirements of Sec. 12.7.2. See Sec. 12.2.2.1 for design of non-conventional elements.

**12.7.2 Engineered Construction:** All engineered wood construction shall meet the requirements of Sec. 12.3 and 12.4.

**12.8 SEISMIC DESIGN CATEGORIES E AND F:** *Structures* assigned to *Seismic Design Categories* E and F shall conform to all of the requirements for engineered construction in accordance with Sec. 12.3 and 12.4 and to the additional requirements of this section.

**Exception:** *Structures* assigned to *Seismic Use Group* I, that are designed and constructed in accordance with the requirements of Sec. 12.5 are permitted.

**12.8.1 Limitations:** *Structures* shall comply with the requirements given below.

**12.8.1.1** Unblocked *structural-use panel sheathing diaphragms* shall not be considered to be part of the *seismic-force-resisting system*. *Structural-use panel sheathing* used for *diaphragms* and *shear walls* that are part of the *seismic-force-resisting system* shall be applied directly to the framing members.

**Exception:** *Structural-use panel sheathing* may be used as a *diaphragm* when fastened over solid lumber planking or laminated decking provided the panel joints and lumber planking or laminated decking joints do not coincide.

**12.8.1.2** In addition to the requirements of Sec. 12.3.4.1, the factored shear resistance ( $\lambda\phi D$ ) for *structural-use panel sheathed shear walls* used to resist seismic forces in *structures* with concrete or masonry walls shall be one-half the values set forth in Tables 12.4.3-2a and b.

**TABLE 12.4.3-1a Factored Shear Resistance in Kips per Foot for Horizontal Wood Diaphragms  
with Framing Members of Douglas Fir-Larch or Southern Pine for Seismic Loading<sup>a,b</sup>**

Panel Grade	Fastener <sup>c</sup>		Minimum nominal panel thickness (in.)	Minimum nominal width of framing (in.)	Lines of fasteners	Blocked Diaphragms							Unblocked Diaphragms <sup>d</sup>	
	Type	Minimum penetration in framing (in.)				Fastener spacing at diaphragm boundaries (all cases), at continuous panel edges parallel to load (Cases 3 and 4) and at all panel edges (Cases 5 and 6) <sup>e</sup>							Fastener spacing at 6 in. centers at supported edges	
						6	4	2-1/2 <sup>f</sup>		2 <sup>f</sup>				
	Spacing per line at other panel edges (in.)							Case 1	Cases 2, 3, 4, 5, and 6					
	6	6				4	4			3	3	2		
Structural I	6d common	1-1/4	3/8	2	1	0.24	0.33	---	0.49	---	0.55	---	0.21	0.16
				3	1	0.27	0.36	---	0.55	---	0.62	---	0.24	0.18
	8d common	1-1/2	3/8	2	1	0.35	0.47	---	0.69	---	0.78	---	0.31	0.23
				3	1	0.39	0.52	---	0.78	---	0.88	---	0.34	0.26
	10d <sup>g</sup> common	1-5/8	15/32	2	1	0.42	0.55	---	0.83	---	0.95	---	0.37	0.28
3				1	0.47	0.62	---	0.94	---	1.07	---	0.42	0.31	
14 gauge staples	2	23/32	3	2	---	0.78	0.78	1.09	1.17	1.35	1.56	---	---	
			4	3	---	1.09	1.17	1.48	1.76	1.87	2.34	---	---	
Sheathing, single floor and other grades covered in Ref. 9-10 and 9-11	6d common	1-1/4	3/8	2	1	0.24	0.33	---	0.49	---	0.55	---	0.21	0.16
				3	1	0.27	0.36	---	0.55	---	0.62	---	0.24	0.18
	8d common	1-1/2	3/8	2	1	0.31	0.42	---	0.62	---	0.71	---	0.28	0.21
				3	1	0.35	0.47	---	0.70	---	0.79	---	0.31	0.23
				2	1	0.33	0.44	---	0.66	---	0.75	---	0.30	0.22
				3	1	0.37	0.49	---	0.74	---	0.84	---	0.33	0.25
	10d <sup>g</sup> common	1-5/8	15/32	2	1	0.35	0.47	---	0.69	---	0.78	---	0.31	0.23
				3	1	0.39	0.52	---	0.78	---	0.88	---	0.34	0.26
				2	1	0.38	0.50	---	0.75	---	0.85	---	0.33	0.25
				3	1	0.42	0.56	---	0.85	---	0.96	---	0.38	0.28
	14 gauge staples	2	23/32	2	1	.042	0.55	---	0.83	---	0.95	---	0.37	0.28
				3	1	0.47	0.62	---	0.94	---	1.07	---	0.42	0.31
				3	2	---	0.84	1.13	1.22	1.59	---	---	---	---
4				2	---	0.98	1.27	1.40	1.81	---	---	---	---	
14 gauge staples	2	23/32	4	3	---	1.22	1.70	1.78	1.96	---	---	---	---	
			4	3	---	0.78	0.78	1.07	1.17	1.33	1.56	---	---	
						---	1.07	1.17	1.46	1.76	1.82	1.96	---	---

**NOTES for TABLE 12.4.3-1a**

<sup>a</sup>  $\lambda = 1.0$       = 0.65

<sup>b</sup>  $l/w$  shall not be more than 4/1 for blocked diaphragms or more than 3/1 for unblocked diaphragms. For framing members of other species set forth in Ref 12-1, Table 12A, with the range of specific gravity (SG) noted, allowable shear values shall be calculated for all panel grades by multiplying the values for Structural I by the following factors: 0.82 for SG equal to or greater than 0.42 but less than 0.49 ( $0.42 \leq SG < 0.49$ ) and 0.65 for SG less than 0.42 ( $SG < 0.42$ ).

<sup>c</sup> Space nails along intermediate framing members at 12 in. centers except where spans are greater than 32 in.; space nails at 6 in. centers.

<sup>d</sup> Blocked values are permitted to be used for 1-1/8 in. panels with tongue-and-groove edges where 1 in. by 3/8 in. crown by No. 16 gauge staples are driven through the tongue-and-groove edges 3/8 in. from the panel edge so as to penetrate the tongue. Staples shall be spaced at one half the boundary nail spacing for Cases 1 and 2 and at one third the boundary nail spacing for Cases 3 through 6.

<sup>e</sup> Maximum shear for Cases 3 through 6 is limited to 1500 pounds per foot.

<sup>f</sup> For values listed for 2 in. nominal framing member width, the framing members at adjoining panel edges shall be 3 in. nominal width. Nails at panel edges shall be placed in two lines at these locations.

<sup>g</sup> Framing at adjoining panel edges shall be 3 in. nominal or wider and nails shall be staggered where 10d nails having penetration into framing of more than 1-5/8 in. are spaced 3 in. or less on center.

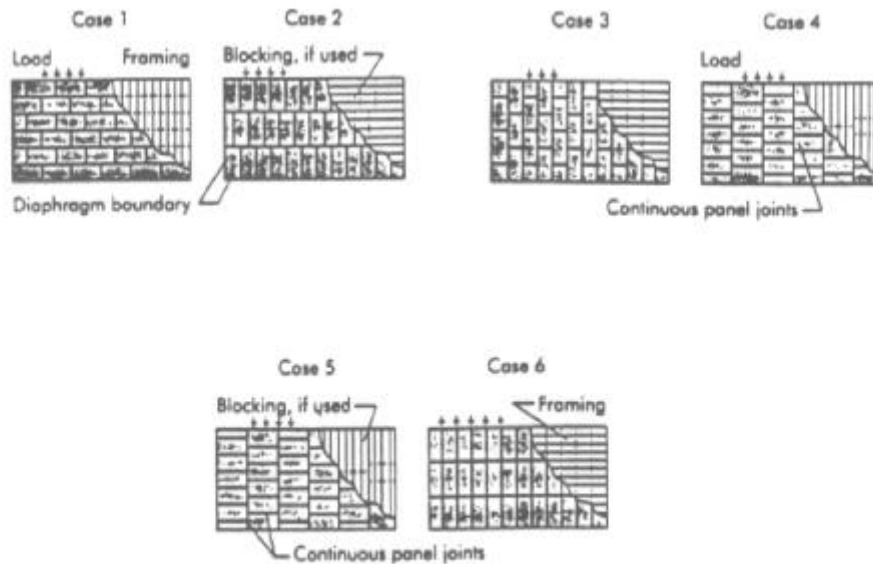



**TABLE 12.4.3-1b Factored Shear Resistance in kiloNewtons per Meter for Horizontal Wood Diaphragms  
with Framing Members of Douglas Fir-Larch or Southern Pine for Seismic Loading<sup>a,b</sup>**

Panel Grade	Fastener <sup>c</sup>		Minimum nominal panel thickness (mm.)	Minimum nominal width of framing (mm.)	Lines of fasteners	Blocked Diaphragms							Unblocked Diaphragms <sup>d</sup>				
	Type	Minimum penetration in framing (mm.)				Fastener spacing at diaphragm boundaries (all cases), at continuous panel edges parallel to load (Cases 3 and 4) and at all panel edges (Cases 5 and 6) (mm) <sup>e</sup>										Fastener spacing at 150 mm centers at supported edges	
						150	100		65 <sup>f</sup>		50 <sup>f</sup>						
						Spacing per line at other panel edges (mm.)										Case 1	Cases 2, 3, 4, 5, and 6
150	150	100	100	75	75	50											
Structural I	6d common	32	9.5	50	1	3.5	4.7	---	7.1	---	8.0	---	3.1	2.4			
						4.0	5.3	---	8.0	---	9.0	---	3.5	2.7			
	8d common	38	9.5	50	1	5.1	6.8	---	10.1	---	11.4	---	4.6	3.4			
						5.7	7.6	---	11.4	---	12.8	---	5.0	3.8			
	10d <sup>g</sup> common	41	12	50	1	6.1	8.1	---	12.1	---	13.8	---	5.4	4.1			
6.8						9.1	---	13.7	---	15.6	---	6.1	4.6				
10d <sup>g</sup> common	41	18	75	2	---	12.3	16.5	17.8	23.3	---	---	---	---	---			
					---	14.3	18.6	20.5	26.8	---	---	---	---	---			
					---	17.8	24.8	26.1	34.1	---	---	---	---	---			
14 gauge staples	50	18	75	2	---	11.4	11.4	15.9	17.1	19.7	22.8	---	---				
					---	15.9	17.1	21.6	25.6	27.3	34.1	---	---				
Sheathing, single floor and other grades covered in Ref. 9-10 and 9-11	6d common	32	9.5	50	1	3.5	4.7	---	7.1	---	8.0	---	3.3	2.4			
						4.0	5.3	---	8.0	---	9.0	---	3.5	2.7			
	8d common	38	9.5	50	1	4.6	6.1	---	9.1	---	10.3	---	4.1	3.0			
						5.1	6.8	---	10.2	---	11.6	---	4.6	3.4			
						11	50	1	4.8	6.5	---	10.9	---	10.9	---	4.4	3.2
						75	1	5.4	7.2	---	12.2	---	12.2	---	4.8	3.6	
	10d <sup>g</sup> common	41	12	50	1	5.1	6.9	---	10.1	---	11.4	---	4.5	3.4			
						5.7	7.6	---	11.4	---	12.8	---	5.0	3.8			
						75	1	5.5	7.3	---	10.9	---	12.4	---	4.8	3.6	
						75	1	6.2	8.2	---	12.3	---	13.9	---	5.5	4.1	
	10d <sup>g</sup> common	41	15	50	1	6.1	8.1	---	12.1	---	13.8	---	5.4	4.1			
						6.8	9.1	---	13.7	---	15.6	---	6.1	4.6			
						75	1	---	12.2	16.5	17.7	23.2	---	---	---	---	
100						2	---	14.2	18.6	20.4	26.5	---	---	---	---		
10d <sup>g</sup> common	41	18	75	2	---	17.7	24.8	26.4	28.6	---	---	---	---				
					100	3	---	17.7	24.8	26.4	28.6	---	---	---	---		
					100	3	---	17.7	24.8	26.4	28.6	---	---	---	---		
14 gauge staples	50	18	75	2	---	11.4	11.4	15.6	17.1	19.4	22.8	---	---				
					---	15.6	17.1	21.2	25.6	26.6	28.6	---	---				

**NOTES for TABLE 12.4.3-1b**

<sup>a</sup>  $\lambda = 1.0 \quad = 0.65$

<sup>b</sup>  $l/w$  shall not be more than 4/1 for blocked diaphragms or more than 3/1 for unblocked diaphragms. For framing members of other species set forth in Ref 12-1, Table 12A, with the range of specific gravity (SG) noted, allowable shear values shall be calculated for all panel grades by multiplying the values for Structural I by the following factors: 0.82 for SG equal to or greater than 0.42 but less than 0.49 ( $0.42 = SG < 0.49$ ) and 0.65 for SG less than 0.42 ( $SG < 0.42$ ).

<sup>c</sup> Space nails along intermediate framing members at 300 mm. centers except where spans are greater than 810 mm.; space nails at 150 mm. centers.

<sup>d</sup> Blocked values are permitted to be used for 28.5 mm. panels with tongue-and-groove edges where 25 mm. by 9 mm. crown by No. 16 gauge staples are driven through the tongue-and-groove edges 9 mm. from the panel edge so as to penetrate the tongue. Staples shall be spaced at one half the boundary nail spacing for Cases 1 and 2 and at one third the boundary nail spacing for Cases 3 through 6.

<sup>e</sup> Maximum shear for Cases 3 through 6 is limited to 22.8 kiloNewtons per meter.

<sup>f</sup> For values listed for 50 mm. nominal framing member width, the framing members at adjoining panel edges shall be 75 mm. nominal width. Nails at panel edges shall be placed in two lines at these locations.

<sup>g</sup> Framing at adjoining panel edges shall be 75 mm nominal or wider and nails shall be staggered where 10d nails having penetration into framing of more than 41 mm are spaced 75 mm or less on center.

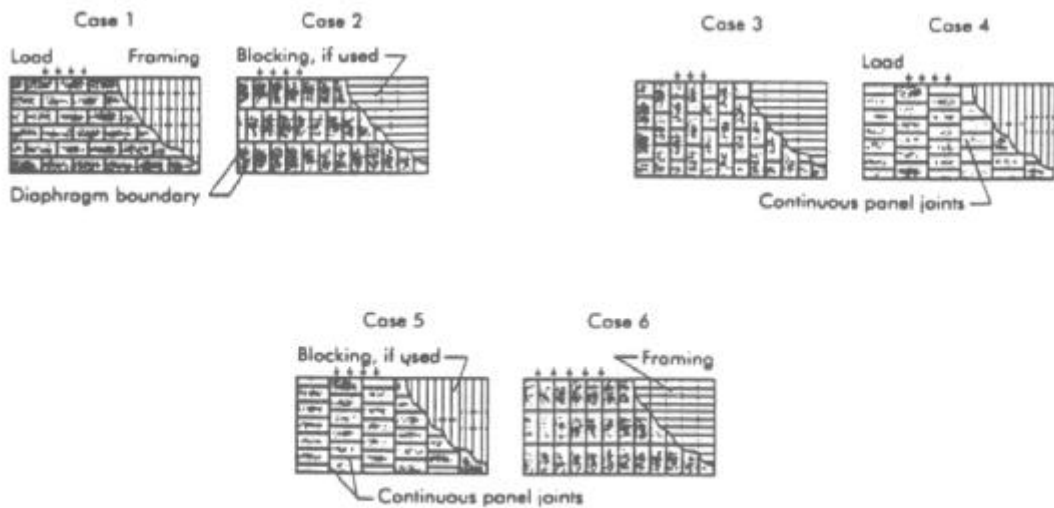



**TABLE 12.4.3-2a Factored Shear Resistance in Kips per Foot (KLF) for Seismic Forces on Structural Use Panel**

**Shear Walls with Framing Members of Douglas Fir-Larch or Southern Pine<sup>a,b,c</sup>**

Panel Grade	Nail Size (Common or Hot-Dipped Galvanized Box)	Minimum Penetration in Framing (in.)	Panel Thickness (in.)	Panel Applied Direct to Framing Nail Spacing at Panel Edges (in.)				Nail Size (Common or Hot-Dipped Galvanized Box)	Panel Applied Over Nail S	
				6	4	3	2 <sup>d</sup>		6	
Structural I	6d	1-1/4	3/8	0.23	0.35	0.46	0.60	8d	0.23	
	8d	1-1/2	3/8	0.27 <sup>f</sup>	0.42 <sup>f</sup>	0.54 <sup>f</sup>	0.71 <sup>f</sup>	10d <sup>e</sup>	0.27 <sup>f</sup>	
	8d	1-1/2	7/16	0.30 <sup>f</sup>	0.46 <sup>f</sup>	0.59 <sup>f</sup>	0.78 <sup>f</sup>	10d <sup>e</sup>	0.30 <sup>f</sup>	
	8d	1-1/2	15/32	0.33	0.50	0.64	0.85	10d <sup>e</sup>	0.33 <sup>f</sup>	
	10d <sup>e</sup>	1-5/8	15/32	0.40	0.60	0.78	1.02		-	
	14 ga staple	2	3/8	0.17	0.26	0.35	0.52		-	
	14 ga staple	2	7/16	0.24	0.36	0.48	0.72		-	
Sheathing, Panel Siding and Other Grades Covered in References 9.10 and 9.11	6d	1-1/4	3/8	0.23	0.35	0.46	0.60	8d	0.23	
	8d	1-1/2	3/8	0.26 <sup>f</sup>	0.37 <sup>f</sup>	0.48 <sup>f</sup>	0.62 <sup>f</sup>	10d <sup>e</sup>	0.26 <sup>f</sup>	
	8d	1-1/2	7/16	0.28 <sup>f</sup>	0.41 <sup>f</sup>	0.53 <sup>f</sup>	0.68 <sup>f</sup>	10d <sup>e</sup>	0.28 <sup>f</sup>	
	8d	1-1/2	15/32	0.30	0.44	0.57	0.75	10d <sup>e</sup>	0.30 <sup>f</sup>	
	10d <sup>e</sup>	1-5/8	15/32	0.36	0.54	0.70	0.90		-	
	10d <sup>e</sup>	1-5/8	19/32	0.40	0.60	0.78	1.02		-	
	14 ga staple	2	3/8	0.15	0.23	0.30	0.45		-	
	14 ga staple	2	7/16	0.21	0.32	0.42	0.63		-	
	14 ga staple	2	15/32	0.24	0.36	0.48	0.72		-	
	(Hot-Dipped Galvanized Casing Nail)							(Hot-Dipped Galvanized Casing Nail)		
Panel Siding as Covered in Reference 9.10	6d	1-1/4	3/8	0.16	0.25	0.32	0.42	8d	0.16	
	8d	1-1/2	3/8	0.19	0.28	0.36	0.48	10d <sup>e</sup>	0.19	

<sup>a</sup>  $\lambda = 1.0$   $\phi = 0.65$

**NOTES for TABLE 12.4.3-2a**

<sup>a</sup>  $\lambda = 1.0$     $\phi = 0.65$

<sup>b</sup> All panel edges backed with 2-inch nominal or wider framing. Panels installed either horizontally or vertically. Space nails at 6 inches on center along intermediate framing members for 3/8-inch panels installed with strong axis parallel to studs spaced 24 inches on center and 12 inches on center for other conditions and panel thicknesses. Allowable shear values for fasteners in framing members of other species set forth in Table 12A of Ref. 12-1 shall be calculated for all grades by multiplying the values for fasteners in STRUCTURAL I by the following factors: 0.82 for species with a specific gravity greater than or equal to 0.42 but less than 0.49 ( $0.42 \leq G < 0.49$ ) and 0.65 for species with a specific gravity less than 0.42 ( $G < 0.42$ ). For panel siding using hot-dipped galvanized casing nails, the shear values shall be the values in the table multiplied by the same factors.

<sup>c</sup> Where panels are applied on both faces of a wall and nail spacing is less than 6 inches on center on either side, panel joints shall be offset to fall on different framing members or framing shall be 3-inch nominal or wider and nails on each side of joint shall be staggered.

<sup>d</sup> Framing at adjoining panel edges shall be 3-inch nominal or wider and nails shall be staggered where nails are spaced 2 inches on center.

<sup>e</sup> Framing at adjoining panel edges shall be 3-inch nominal or wider and nails shall be staggered where 10d nails having penetration into framing of more than 1-5/8 inches are spaced 3 inches or less on center.

<sup>f</sup> The values for 3/8-inch and 7/16-inch panels applied directly to framing are permitted to be increased to the values shown for 15/32-inch panels provided studs are spaced a maximum of 16 inches on center or panel is applied with strong axis across studs.

**TABLE 12.4.3-2b Factored Shear Resistance in kiloNewtons per Meter (kN/m) for Seismic Forces on Structural Use Panel  
Shear Walls with Framing Members of Douglas Fir-Larch or Southern Pine<sup>a,b,c</sup>**

Panel Grade	Nail Size (Common or Hot-Dipped Galvanized Box)	Minimum Penetration in Framing (mm)	Panel Thickness (mm)	Panel Applied Direct to Framing Nail Spacing at Panel Edges (mm)				Nail Size (Hot-Dipped Common or Galvanized Box)	Panel Applied Over 12.7 mm or 15.9 mm Gypsum Sheathing Nail Spacing at Panel Edges (mm)			
				150	100	75	50 <sup>d</sup>		150	100	75	50 <sup>d</sup>
Structural I	6d	32	9.5	3.4	5.1	6.7	8.7	8d	3.4	5.1	6.7	8.7
	8d	38	9.5	3.9 <sup>e</sup>	6.1 <sup>f</sup>	7.9 <sup>e</sup>	10.4 <sup>f</sup>	10d <sup>e</sup>	4.8	7.3	9.4	12.5
	8d	38	11	4.4 <sup>f</sup>	6.7 <sup>f</sup>	8.6 <sup>f</sup>	11.4 <sup>f</sup>	10d <sup>e</sup>	4.8	7.3	9.4	12.5
	8d	38	12	4.8	7.3	9.4	12.5	10d <sup>e</sup>	4.8	7.3	9.4	12.5
	10d <sup>e</sup>	41	12	5.8	8.7	11.3	14.9		-	-	-	-
	14 ga staple	50	9.5	2.5	3.7	5.1	7.5		-	-	-	-
	14 ga staple	50	11	3.5	5.2	7.1	10.5		-	-	-	-
Sheathing, Panel Siding and Other Grades Covered in References 9.10 and 9.11	6d	32	9.5	3.4	5.1	6.7	8.7	8d	3.4	5.1	6.7	8.7
	8d	38	9.5	3.8 <sup>e</sup>	5.5 <sup>f</sup>	7.0 <sup>e</sup>	9.0 <sup>f</sup>	10d <sup>e</sup>	4.4	6.5	8.4	10.9
	8d	38	11	4.1 <sup>f</sup>	6.0 <sup>f</sup>	7.7 <sup>f</sup>	10.5 <sup>f</sup>	10d <sup>e</sup>	4.4	6.5	8.4	10.9
	8d	38	12	4.4	6.5	8.4	10.9	10d <sup>e</sup>	4.4	6.5	8.4	10.9
	10d <sup>e</sup>	41	12	5.3	7.9	10.2	13.2		-	-	-	-
	10d <sup>e</sup>	41	15	5.8	8.7	11.3	14.9		-	-	-	-
	14 ga staple	50	9.5	2.2	3.3	4.4	6.5		-	-	-	-
	14 ga staple	50	11	3.1	4.6	6.1	9.6		-	-	-	-
	14 ga staple	50	12	3.5	5.3	7.0	10.5		-	-	-	-
	(Hot-Dipped Galvanized Casing Nail)							(Hot-Dipped Galvanized Casing Nail)				
Panel Siding as Covered in Reference 9.10	6d	32	9.5	2.4	3.6	4.7	6.1	8d	2.4	3.6	4.7	6.1
	8d	38	9.5	2.7	4.1	5.3	7.0	10d <sup>e</sup>	2.7	4.1	5.3	7.0

**NOTES for TABLE 12.4.3-2b**

<sup>a</sup>  $\lambda = 1.0$     $\phi = 0.65$

<sup>b</sup> All panel edges backed with 38 mm nominal or wider framing. Panels installed either horizontally or vertically. Space nails at 150 mm on center along intermediate framing members for 9 mm panels installed with strong axis parallel to studs spaced 610 mm on center and 305 mm on center for other conditions and panel thicknesses. Allowable shear values for fasteners in framing members of other species set forth in Table 12A of Ref. 12.- shall be calculated for all grades by multiplying the values for fasteners in STRUCTURAL I by the following factors: 0.82 for species with a specific gravity greater than or equal to 0.42 but less than 0.49 ( $0.42 \leq G < 0.49$ ) and 0.65 for species with a specific gravity less than 0.42 ( $G < 0.42$ ). For panel siding using hot-dipped galvanized casing nails, the shear values shall be the values in the table multiplied by the same factors.

<sup>c</sup> Where panels are applied on both faces of a wall and nail spacing is less than 610 mm on center on either side, panel joints shall be offset to fall on different framing members or framing shall be 64 mm or wider and nails on each side of joint shall be staggered.

<sup>d</sup> Framing at adjoining panel edges shall be 64 mm or wider and nails shall be staggered where nails are spaced 50 mm on center.

<sup>e</sup> Framing at adjoining panel edges shall be 64 mm or wider and nails shall be staggered where 10d nails having penetration into framing of more than 41 mm are spaced 76 mm or less on center.

<sup>f</sup> The values for 9 mm and 11 mm panels applied directly to framing are permitted to be increased to the values shown for 12 mm panels provided studs are spaced a maximum of 406 mm on center or panel is applied with strong axis across studs.

**TABLE 12.5.1-1 Conventional Light-Frame Construction Braced Wall Requirements**

<b>Seismic Performance Category</b>	<b>Maximum Distance Between Braced Walls</b>	<b>Maximum Number of <i>Stories Above Grade</i> Permitted <sup>a</sup></b>
A <sup>b</sup>	35 ft (10.6 m)	3
B	35 ft (10.6 m)	3
C	25 ft (7.6 m)	2
D and E (Seismic Use Group I)	25 ft (7.6 m)	1 <sup>c</sup>
E (Seismic Use Group II) and F	Conventional construction not permitted; conformance with Sec. 12.3 required.	

<sup>a</sup> A cripple stud wall is considered to be a *story above grade*. Maximum bearing wall height shall not exceed 10 ft. (3 m)

<sup>b</sup> See exceptions to Sec. 1.2.1.

<sup>c</sup> Detached one- and two-family dwellings are permitted to be two *stories above grade*.



**TABLE 12.5.2-1 Conventional Light-Frame Construction Braced Wall Requirements in Minimum Length of Wall Bracing per Each 25 Linear Feet (7.6 m) of Braced Wall Line<sup>a</sup>**

Story Location	Sheathing Type <sup>b</sup>	$0.125g \leq S_{DS} < 0.25g$	$0.25g \leq S_{DS} < 0.375g$	$0.375g \leq S_{DS} < 0.50g$	$0.50g \leq S_{DS} < 0.75g$	$0.75g \leq S_{DS} < 1.0g^e$
Top or only story above grade	G-P <sup>d</sup>	8 ft 0 in. (2440 mm)	8 ft 0 in. (2440 mm)	10 ft 8 in. (3250 mm)	14 ft 8 in. (4470 mm)	18 ft 8 in. <sup>c</sup> (5690 mm)
	S-W	4 ft 0 in. (1220 mm)	4 ft 0 in. (1220 mm)	5 ft 4 in. (1625 mm)	8 ft 0 in. (2440 mm)	9 ft 4 in. <sup>c</sup> (2845 mm)
Story below top story above grade	G-P <sup>d</sup>	10 ft 8 in. (3250 mm)	14 ft 8 in. (4470 mm)	18 ft. 8 in. <sup>c</sup> (6590 mm)	NP	NP
	S-W	5 ft 4 in. (1625 mm)	6 ft 8 in. (2030 mm)	10 ft 8 in. <sup>c</sup> (3250 mm)	13 ft 4 in. <sup>c</sup> (4065 mm)	17 ft 4 in. <sup>c</sup> (5280 mm)
Bottom story of 3 stories above grade	G-P <sup>d</sup>	14 ft 8 in. (4470 mm)	Conventional construction not permitted; conformance with Sec. 12.3 required.			
	S-W	8 ft 0 in. (2440 mm)				

<sup>a</sup> Minimum length of panel bracing of one face of wall for S-W sheathing or both faces of wall for G-P sheathing;  $h/w$  ratio shall not exceed 2/1, except structures in *Seismic Design Category B* need only meet the requirements of Sec. 602.9 of Ref. 12-5. For S-W panel bracing of the same material on two faces of the wall, the minimum length is permitted to be one half the tabulated value but the  $h/w$  ratio shall not exceed 2/1 and design for uplift is required.

<sup>b</sup> G-P = gypsumboard, fiberboard, particleboard, lath and plaster, or gypsum sheathing boards; S-W = structural-use panels and diagonal wood sheathing. NP = not permitted.

<sup>c</sup> Applies to one- and two-family detached dwellings only.

<sup>d</sup> Nailing shall be as follows:

For ½ in. (13 mm) gypsum board, 5d (0.086 in., 2.2 mm diameter) coolers at 7 in. (178 mm) centers;

For ⅝ in. (16mm) gypsum board, 6d (0.092 in. (2.3 mm) diameter) at 7 in (178 mm) centers;

For gypsum sheathing board, 1¾ in. long by 7/16 in. (44 by 11 mm) head, diamond point galvanized at 4 in. (100mm) centers;

For gypsum lath, No. 13 gauge (0.092 in., 2.3 mm) by 1⅝ in. long, 19/64 in. (29 by 7.5 mm) head, plasterboard at 5 in. (125 mm) centers;

For Portland cement plaster, No. 11 gauge (0.120 in., 3 mm) by 1½ in. long, 7/16 in. head (89 by 11 mm) at 6 in. (150 mm) centers;

For fiberboard and particleboard, No. 11 gauge (0.120 in., 3 mm) by 1½ in. (38 mm) long, 7/16 in. (11 mm) head, galvanized at 3 in. (76 mm) centers.

For structural wood sheathing, the minimum nail size and maximum spacing shall be in accordance with the minimum nails size and maximum spacing allowed for each thickness sheathing in Tables 12.4.3-2a and b.

Nailing as specified above shall occur at all panel edges at studs, at top and bottom plates, and, where occurring, at blocking.

<sup>e</sup> Where  $S_{DS} > 1.0g$ , conventional construction is not permitted.

## Chapter 13

### SEISMICALLY ISOLATED STRUCTURES DESIGN REQUIREMENTS

**13.1 GENERAL:** Every seismically isolated *structure* and every portion thereof shall be designed and constructed in accordance with the requirements of this section and the applicable requirements of Chapter 1. The lateral-force-resisting system and the *isolation system* shall be designed to resist the deformations and stresses produced by the effects of seismic ground motions as provided in this section.

#### 13.2 CRITERIA SELECTION:

**13.2.1 Basis for Design:** The procedures and limitations for the design of seismically isolated *structures* shall be determined considering zoning, site characteristics, vertical acceleration, cracked section properties of concrete and masonry members, *Seismic Use Group*, configuration, structural system, and height in accordance with Sec. 5.2 except as noted below.

**13.2.2 Stability of the Isolation System:** The stability of the vertical load-carrying *elements* of the *isolation system* shall be verified by analysis and test, as required, for lateral seismic displacement equal to the *total maximum displacement*.

**13.2.3 Seismic Use Group:** All portions of the *structure*, including the *structure* above the *isolation system*, shall be assigned a *Seismic Use Group* in accordance with the requirements of Sec. 1.3.

**13.2.4 Configuration Requirements:** Each *structure* shall be designated as being regular or irregular on the basis of the structural configuration above the *isolation system* in accordance with the requirements of Sec. 5.2.

#### 13.2.5 Selection of Lateral Response Procedure:

**13.2.5.1 General:** Any seismically isolated *structure* is permitted to be and certain seismically isolated *structures* defined below shall be designed using the dynamic lateral response procedure of Sec. 13.4.

**13.2.5.2 Equivalent Lateral Force Procedure:** The equivalent-lateral-response procedure of Sec. 13.3 is permitted to be used for design of a seismically isolated *structure* provided that:

1. The *structure* is located at a site with  $S_f$  less than or equal to 0.60g ;
2. The *structure* is located on a Class A, B, C, or D site;
3. The *structure* above the *isolation interface* is not more than four stories or 65 ft (20 m) in height;
4. The effective period of the isolated *structure*,  $T_M$ , is less than or equal to 3.0 sec.

5. The effective period of the isolated *structure*,  $T_D$ , is greater than three times the elastic, fixed-base period of the *structure* above the *isolation system* as determined by Eq. 5.3.3.1-1 or 5.3.3.1-2;
6. The *structure* above the *isolation system* is of regular configuration; and
7. The *isolation system* meets all of the following criteria:
  - a. The effective stiffness of the *isolation system* at the *design displacement* is greater than one third of the effective stiffness at 20 percent of the *design displacement*,
  - b. The *isolation system* is capable of producing a restoring force as specified in Sec. 13.6.2.4,
  - c. The *isolation system* has force-deflection properties that are independent of the rate of loading,
  - d. The *isolation system* has force-deflection properties that are independent of vertical load and bilateral load, and
  - e. The *isolation system* does not limit maximum capable earthquake displacement to less than  $S_M/S_{DI}$  times the *total design displacement*.

**13.2.5.3 Dynamic Analysis:** A dynamic analysis is permitted to be used for the design of any *structure* but shall be used for the design of all isolated *structures* not satisfying Sec. 13.2.5.2. The dynamic lateral response procedure of Sec. 13.4 shall be used for design of seismically isolated *structures* as specified below.

**13.2.5.3.1 Response-Spectrum Analysis:** Response-spectrum analysis is permitted to be used for design of a seismically isolated *structure* provided that:

1. The *structure* is located on a Class A, B, C, or D site and
2. The *isolation system* meets the criteria of Item 7 of Sec. 13.2.5.2.

**13.2.5.3.2 Time-History Analysis:** Time-history analysis is permitted to be used for design of any seismically isolated *structure* and shall be used for design of all seismically isolated *structures* not meeting the criteria of Sec. 13.2.5.3.1.

**13.2.5.3.3 Site-Specific Design Spectra:** Site-specific ground-motion spectra of the *design earthquake* and the *maximum considered earthquake* developed in accordance with Sec. 13.4.4.1 shall be used for design and analysis of all seismically isolated *structures* if any one of the following conditions apply:

1. The *structure* is located on a Class E or F site or
2. The *structure* is located at a site with  $S_I$  greater than 0.60g .

### 13.3 EQUIVALENT LATERAL FORCE PROCEDURE:

**13.3.1 General:** Except as provided in Sec. 13.4, every seismically isolated *structure* or portion thereof shall be designed and constructed to resist minimum earthquake displacements and forces as specified by this section and the applicable requirements of Sec. 5.3.

**13.3.2 Deformation Characteristics of the Isolation System:** Minimum lateral earthquake *design displacement* and forces on seismically isolated *structures* shall be based on the deformation characteristics of the *isolation system*. The deformation characteristics of the *isolation system* shall explicitly include the effects of the wind-restraint system if such a system is used to meet the design requirements of these *Provisions*. The deformation characteristics of the *isolation system* shall be based on properly substantiated tests performed in accordance with Sec. 13.9.

#### 13.3.3 Minimum Lateral Displacements:

**13.3.3.1 Design Displacement:** The *isolation system* shall be designed and constructed to withstand minimum lateral earthquake displacements that act in the direction of each of the main horizontal axes of the *structure* in accordance with the following:

$$D_D = \left( \frac{g}{4} \right) \frac{S_{D1} T_D}{B_D} \quad (13.3.3.1)$$

where:

- $g$  = acceleration of gravity. The units of the acceleration of gravity,  $g$ , are in./sec<sup>2</sup> (mm/sec<sup>2</sup>) if the units of the *design displacement*,  $D_D$ , are inches (mm).
- $S_{D1}$  = design 5 percent damped spectral acceleration at 1 sec period as determined in Sec. 4.1.1.
- $T_D$  = effective period, in seconds (sec), of seismically isolated *structure* at the *design displacement* in the direction under consideration, as prescribed by Eq. 13.3.3.2.
- $B_D$  = numerical coefficient related to the *effective damping* of the *isolation system* at the design displacement,  $D_D$ , as set forth in Table 13.3.3.1.

**TABLE 13.3.3.1 Damping Coefficient,  $B_D$  or  $B_M$**

Effective Damping, $D$ or $M$ (Percentage of Critical) <sup>a,b</sup>	$B_D$ or $B_M$ Factor
≤ 2%	0.8
5%	1.0
10%	1.2
20%	1.5
30%	1.7
40%	1.9
≥ 50%	2.0

**NOTES for Table 13.3.3.1**

<sup>a</sup> The damping coefficient shall be based on the *effective damping* of the *isolation system* determined in accordance with the requirements of Sec. 13.9.5.2.

<sup>b</sup> The damping coefficient shall be based on linear interpolation for *effective damping* values other than those given.

**13.3.3.2 Effective Period:** The effective period of the isolated *structure*,  $T_D$ , shall be determined using the deformational characteristics of the *isolation system* in accordance with the following equation:

$$T_D = 2 \sqrt{\frac{W}{k_{Dmin}g}} \quad (13.3.3.2)$$

where:

- $W$  = total seismic *dead load* weight of the *structure* above the *isolation interface* as defined in Sec. 5.3.2 and 5.5.3 (kip or kN) .
- $k_{Dmin}$  = minimum effective stiffness, in kips/inch (kN/mm), of the *isolation system* at the *design displacement* in the horizontal direction under consideration as prescribed by Eq. 13.9.5.1-2.
- $g$  = acceleration of gravity. The units of the acceleration of gravity,  $g$ , are in./sec<sup>2</sup> (mm/sec<sup>2</sup>) if the units of the *design displacement*,  $D_D$ , are inches (mm).

**13.3.3.3 Maximum Displacement:** The maximum displacement of the *isolation system*,  $D_M$ , in the most critical direction of horizontal response shall be calculated in accordance with the formula:

$$D_M = \frac{\left(\frac{g}{4}\right)^2 S_{M1} T_M}{B_M} \quad (13.3.3.3)$$

where:

- $g$  = acceleration of gravity. The units of the acceleration of gravity,  $g$ , are in./sec<sup>2</sup> (mm/sec<sup>2</sup>) if the units of the *design displacement*,  $D_D$ , are inches (mm).
- $S_{M1}$  = maximum considered 5 percent damped spectral acceleration at 1 sec period as determined in Sec. 4.1.1.
- $T_M$  = effective period, in seconds (sec), of seismic-isolated *structure* at the maximum displacement in the direction under consideration as prescribed by Eq. 13.3.3.4.
- $B_M$  = numerical coefficient related to the *effective damping* of the *isolation system* at the maximum displacement,  $D_D$ , as set forth in Table 13.3.3.1.

**13.3.3.4 Effective Period at Maximum Displacement:** The effective period of the isolated *structure* at maximum displacement,  $T_M$ , shall be determined using the deformational characteristics of the *isolation system* in accordance with the equation:

$$T_M = 2 \sqrt{\frac{W}{k_{Mmin}g}} \quad (13.3.3.4)$$

where:

- $W$  = total seismic *dead load* weight of the *structure* above the *isolation interface* as defined in Sec. 5.3.2 and 5.5.3 (kip or kN).
- $k_{Mmin}$  = minimum effective stiffness, in kips/inch (kN/mm), of the *isolation system* at the maximum displacement in the horizontal direction under consideration as prescribed by Eq. 13.9.5.1-4.
- $g$  = the acceleration due to gravity. The units of the acceleration of gravity,  $g$ , are in./sec<sup>2</sup> (mm/sec<sup>2</sup>) if the units of the *design displacement*,  $D_D$ , are inches (mm).

**13.3.3.5 Total Displacement:** The *total design displacement*,  $D_{TD}$ , and the *total maximum displacement*,  $D_{TM}$ , of *elements* of the *isolation system* shall include additional displacement due to actual and accidental torsion calculated considering the spatial distribution of the lateral stiffness of the *isolation system* and the most disadvantageous location of mass eccentricity.

The *total design displacement*,  $D_{TD}$ , and the *total maximum displacement*,  $D_{TM}$ , of *elements* of an *isolation system* with uniform spatial distribution of lateral stiffness shall not be taken as less than that prescribed by the following equations:

$$D_{TD} = D_D \left[ 1 + y \left( \frac{12e}{b^2 + d^2} \right) \right] \quad (13.3.3.5-1)$$

$$D_{TM} = D_M \left[ 1 + y \left( \frac{12e}{b^2 + d^2} \right) \right] \quad (13.3.3.5-2)$$

where:

- $D_D$  = *design displacement*, in inches (mm), at the center of rigidity of the *isolation system* in the direction under consideration as prescribed by Eq. 13.3.3.1.
- $D_M$  = maximum displacement, in inches (mm), at the center of rigidity of the *isolation system* in the direction under consideration as prescribed in Eq. 13.3.3.3.
- $y$  = the distance, in feet (mm), between the center of rigidity of the *isolation system* rigidity and the *element* of interest measured perpendicular to the direction of seismic loading under consideration.
- $e$  = the actual eccentricity, in feet (mm), measured in plan between the center of mass of the *structure* above the *isolation interface* and the center of rigidity of the *isolation system*,

plus accidental eccentricity, in feet (mm), taken as 5 percent of the longest plan dimension of the *structure* perpendicular to the direction of force under consideration.

$b$  = the shortest plan dimension of the *structure*, in feet (mm), measured perpendicular to  $d$ .

$d$  = the longest plan dimension of the *structure*, in feet (mm).

The *total design displacement*,  $D_{TD}$ , and the *total maximum displacement*,  $D_{TM}$ , is permitted to be taken as less than the value prescribed by Eq. 13.3.3.5-1 and Eq. 13.3.3.5-2, respectively, but not less than 1.1 times  $D_D$  and  $D_M$ , respectively, provided the *isolation system* is shown by calculation to be configured to resist torsion accordingly.

### 13.3.4 Minimum Lateral Forces:

**13.3.4.1 Isolation System and Structural Elements At or Below the Isolation System:** The *isolation system*, the foundation, and all structural *elements* below the *isolation system* shall be designed and constructed to withstand a minimum lateral seismic force,  $V_b$ , using all of the appropriate provisions for a nonisolated *structure* where:

$$V_b = k_{Dmax} D_D \quad (13.3.4.1)$$

where:

$k_{Dmax}$  = maximum effective stiffness, in kips/inch (kN/mm), of the *isolation system* at the *design displacement* in the horizontal direction under consideration as prescribed by Eq. 13.9.5.1-1.

$D_D$  = *design displacement*, in inches (mm), at the center of rigidity of the *isolation system* in the direction under consideration as prescribed by Eq. 13.3.3.1.

In all cases,  $V_b$  shall not be taken as less than the maximum force in the *isolation system* at any displacement up to and including the *design displacement*.

**13.3.4.2 Structural Elements Above the Isolation System:** The *structure* above the *isolation system* shall be designed and constructed to withstand a minimum shear force,  $V_s$ , using all of the appropriate provisions for a nonisolated *structure* where:

$$V_s = \frac{k_{Dmax} D_D}{R_I} \quad (13.3.4.2)$$

where:

$k_{Dmax}$  = maximum effective stiffness, in kips/inch (kN/mm), of the *isolation system* at the *design displacement* in the horizontal direction under consideration as prescribed by Eq. 13.9.5.1-1.

$D_D$  = *design displacement*, in inches (mm), at the center of rigidity of the *isolation system* in the direction under consideration as prescribed by Eq. 13.3.3.1.

$R_I$  = numerical coefficient related to the type of *lateral-force-resisting system* above the *isolation system*.

The  $R_f$  factor shall be based on the type of *lateral-force-resisting system* used for the *structure* above the *isolation system* and shall be 3/8 of the  $R$  value given in Table 5.2.2 with an upper bound value not to exceed 2.0 and a lower bound value not to be less than 1.0.

**13.3.4.3 Limits on  $V_s$ :** The value of  $V_s$  shall be taken as not less than the following:

1. The lateral seismic force required by Sec. 5.3 for a fixed-*base structure* of the same weight,  $W$ , and a period equal to the isolated period,  $T_D$ ;
2. The *base shear* corresponding to the factored design wind load; and
3. The lateral seismic force required to fully activate the *isolation system* (e.g., the yield level of a softening system, the ultimate capacity of a sacrificial wind-restraint system, or the break-away friction level of a sliding system) factored by 1.5.

**13.3.5 Vertical Distribution of Force:** The total force shall be distributed over the height of the *structure* above the *isolation interface* in accordance with the following equation:

$$F_x = \frac{V_s w_x h_x}{\sum_{i=1}^n w_i h_i} \quad (13.3.5)$$

where:

- $V_s$  = total lateral seismic design force or shear on *elements* above the *isolation system* as prescribed by Eq. 13.3.4.2.
- $W_x$  = portion of  $W$  that is located at or assigned to Level  $x$ .
- $h_x$  = height above the *base* Level  $x$ .
- $w_i$  = portion of  $W$  that is located at or assigned to Level  $I$ , respectively.
- $h_i$  = height above the *base* Level  $I$ .

At each level designated as  $x$ , the force,  $F_x$ , shall be applied over the area of the *structure* in accordance with the mass distribution at the level. Stresses in each structural *element* shall be calculated as the effect of force,  $F_x$ , applied at the appropriate levels above the *base*.

**13.3.6 Drift Limits:** The maximum interstory drift of the *structure* above the *isolation system* shall not exceed  $0.015h_{sx}$ . The drift shall be calculated by Eq. 5.3.7-1 with the  $C_d$  factor of the isolated *structure* equal to the  $R_f$  factor defined in Sec. 13.3.4.2.

## 13.4 DYNAMIC LATERAL RESPONSE PROCEDURE:

**13.4.1 General:** As required by Sec. 13.2, every seismically isolated *structure* or portion thereof shall be designed and constructed to resist earthquake displacements and forces as specified in this section and the applicable requirements of Sec. 5.4.

**13.4.2 Isolation System and Structural Elements Below the Isolation System:** The *total design displacement* of the *isolation system* shall be taken as not less than 90 percent of  $D_{TD}$  as specified by Sec. 13.3.3.5.



The *total maximum displacement* of the *isolation system* shall be taken as not less than 80 percent of  $D_{TM}$  as specified by Sec. 13.3.3.5 .

The design lateral shear force on the *isolation system* and structural *elements* below the *isolation system* shall be taken as not less than 90 percent of  $V_b$  as prescribed by Eq. 13.3.4.1.

The limits of the first and second paragraphs of Sec. 13.4.2 shall be evaluated using values of  $D_{TD}$  and  $D_{TM}$  determined in accordance with Sec. 13.3.3 except that  $D'_D$  is permitted to be used in lieu of  $D_D$  and  $D'_M$  is permitted to be used in lieu of  $D_M$  where  $D'_D$

and are prescribed by the following equations:

$$D'_D = \frac{D_D}{\sqrt{1 + \left(\frac{T}{T_D}\right)^2}} \quad (12.4.2-1)$$

$$D'_M = \frac{D_M}{\sqrt{1 + \left(\frac{T}{T_M}\right)^2}} \quad (13.4.2-2)$$

where:

$D_D$  = *design displacement*, in inches (mm), at the center of rigidity of the *isolation system* in the direction under consideration as prescribed by Eq. 13.3.3.1.

$D_M$  = maximum displacement in inches (mm), at the center of rigidity of the *isolation system* in the direction under consideration as prescribed by Eq. 13.3.3.3.

$T$  = elastic, *fixed-base* period of the *structure* above the *isolation system* as determined by Sec. 5.3.3.

$T_D$  = effective period, in seconds (sec), of the seismically isolated *structure* at the *design displacement* in the direction under consideration as prescribed by Eq. 13.3.3.2.

$T_M$  = effective period, in seconds (sec), of the seismically isolated *structure* at the maximum displacement in the direction under consideration as prescribed by Eq. 13.3.3.4.

**13.4.3 Structural Elements Above the Isolation System:** The design lateral shear force on the *structure* above the *isolation system*, if regular in configuration, shall be taken as not less than 80 percent of  $V_s$ , as prescribed by Eq. 13.3.4.2 and the limits specified by Sec. 13.3.4.3.

**Exception:** The design lateral shear force on the *structure* above the *isolation system*, if regular in configuration, is permitted to be taken as less than 80 percent, but not less than 60 percent of  $V_s$ , provided time-history analysis is used for design of the *structure*.

The design lateral shear force on the *structure* above the *isolation system*, if irregular in configuration, shall be taken as not less than  $V_s$ , as prescribed by Eq. 13.3.4.2 and the limits specified by Sec. 13.3.4.3.

**Exception:** The design lateral shear force on the *structure* above the *isolation system*, if irregular in configuration, is permitted to be taken as less than 100 percent, but not less than 80 percent of  $V_s$ , provided time-history analysis is used for design of the *structure*.

#### 13.4.4 Ground Motion:

**13.4.4.1 Design Spectra:** Properly substantiated site-specific spectra are required for the design of all *structures* located on a Class E or F site or located at a site with  $S_I$  greater than  $0.60g$ . *Structures* that do not require site-specific spectra and for which site-specific spectra have not been calculated shall be designed using the response spectrum shape given in Figure 1.4.2.6.

A design spectrum shall be constructed for the *design earthquake*. This design spectrum shall be taken as not less than the *design earthquake* response spectrum given in Figure 1.4.2.6.

**Exception:** If a site-specific spectrum is calculated for the *design earthquake*, the design spectrum is permitted to be taken as less than 100 percent but not less than 80 percent of the *design earthquake* response spectrum given in Figure 4.1.2.6.

A design spectrum shall be constructed for the *maximum considered earthquake*. This design spectrum shall be taken as not less than 1.5 times the *design earthquake* response spectrum given in Figure 4.12.6. This design spectrum shall be used to determine the *total maximum displacement* and overturning forces for design and testing of the *isolation system*.

**Exception:** If a site-specific spectrum is calculated for the *maximum considered earthquake*, the design spectrum is permitted to be taken as less than 100 percent but not less than 80 percent of 1.5 times the *design earthquake* response spectrum given in Figure 4.1.2.6.

**13.4.4.2 Time Histories:** Pairs of appropriate horizontal ground motion time history *components* shall be selected and scaled from not less than three recorded events. Appropriate time histories shall be based on recorded events with magnitudes, fault distances and source mechanisms that are consistent with those that control the *design earthquake* (or *maximum considered earthquake*). Where three appropriate recorded ground motion time history pairs are not available, appropriate simulated ground motion time history pairs are permitted to be used to make up the total number required. For each pair of horizontal ground-motion *components*, the square root sum of the squares of the 5 percent damped spectrum of the scaled, horizontal *components* shall be constructed. The motions shall be scaled such that the average value of the square-root-sum-of-the-squares spectra does not fall below 1.3 times the 5 percent damped spectrum of the *design earthquake* (or *maximum considered earthquake*) by more than 10 percent for periods from  $0.5T_D$  seconds to  $1.25T_M$  seconds.

#### 13.4.5 Mathematical Model:

**13.4.5.1 General:** The mathematical models of the isolated *structure* including the *isolation system*, the *lateral-force-resisting system*, and other structural *elements* shall conform to Sec. 5.4.2 and to the requirements of Sec. 13.4.5.2 and 13.4.5.3, below.

**13.4.5.2 Isolation System:** The *isolation system* shall be modeled using deformational characteristics developed and verified by test in accordance with the requirements of Sec. 13.3.2. The *isolation system* shall be modeled with sufficient detail to:

1. Account for the spatial distribution of *isolator units*;

2. Calculate translation, in both horizontal directions, and torsion of the *structure* above the *isolation interface* considering the most disadvantageous location of mass eccentricity;
3. Assess overturning/uplift forces on individual *isolator units*; and
4. Account for the effects of vertical load, bilateral load, and/or the rate of loading if the force deflection properties of the *isolation system* are dependent on one or more of these attributes.

### 13.4.5.3 Isolated Building:

**13.4.5.3.1 Displacement:** The maximum displacement of each floor and the *total design displacement* and *total maximum displacement* across the *isolation system* shall be calculated using a model of the isolated *structure* that incorporates the force-deflection characteristics of nonlinear *elements* of the *isolation system* and the *lateral-force-resisting system*.

*Lateral-force-resisting systems* with nonlinear *elements* include, but are not limited to, irregular structural systems designed for a lateral force less than 100 percent and regular structural systems designed for a lateral force less than 80 percent of  $V_s$ , as prescribed by Eq. 13.3.4.2 and the limits specified by Sec. 13.3.4.3.

**13.4.5.3.2 Forces and Displacements in Elements of the Lateral-Force-Resisting System:** Design forces and displacements in *elements* of the *lateral-force-resisting system* are permitted to be calculated using a linear elastic model of the isolated *structure* provided that:

1. Stiffness properties assumed for nonlinear isolation-system *components* are based on the maximum effective stiffness of the *isolation system* and
2. No *elements* of the *lateral-force-resisting system* of the *structure* above the *isolation system* are nonlinear .

### 13.4.6 Description of Analysis Procedures:

**13.4.6.1 General:** Response-spectrum and time-history analyses shall be performed in accordance with Sec. 5.4 and the requirements of this section.

**13.4.6.2 Input Earthquake:** The *design earthquake* shall be used to calculate the *total design displacement* of the *isolation system* and the lateral forces and displacements of the isolated *structure*. The *maximum considered earthquake* shall be used to calculate the *total maximum displacement* of the *isolation system*.

**13.4.6.3 Response-Spectrum Analysis.** Response-spectrum analysis shall be performed using a modal damping value for the fundamental mode in the direction of interest not greater than the *effective damping* of the *isolation system* or 30 percent of critical, whichever is less. Modal damping values for higher modes shall be selected consistent with those appropriate for response spectrum analysis of the *structure* above the *isolation system* with a fixed *base*.

Response-spectrum analysis used to determine the *total design displacement* and the *total maximum displacement* shall include simultaneous excitation of the model by 100 percent of the most critical direction of ground motion and 30 percent of the ground motion on the orthogonal axis. The maximum displacement of the *isolation system* shall be calculated as the vectorial sum of the two orthogonal displacements.

The design shear at any *story* shall not be less than the *story* shear obtained using Eq. 13.3.5 and a value of  $V_s$  taken as that equal to the *base shear* obtained from the response-spectrum analysis in the direction of interest.

**13.4.6.4 Time-History Analysis:** Time-history analysis shall be performed with at least three appropriate pairs of horizontal time-history *components* as defined in Sec. 13.4.4.2.

Each pair of time histories shall be applied simultaneously to the model considering the most disadvantageous location of mass eccentricity. The maximum displacement of the *isolation system* shall be calculated from the vectorial sum of the two orthogonal *components* at each time step.

The parameter of interest shall be calculated for each time-history analysis. If three time-history analyses are performed, the maximum response of the parameter of interest shall be used for design. If seven or more time-history analyses are performed, the average value of the response parameter of interest shall be used for design.

### 13.4.7 Design Lateral Force:

**13.4.7.1 Isolation System and Structural Elements At or Below the Isolation System:** The *isolation system*, foundation, and all structural *elements* below the *isolation system* shall be designed using all of the appropriate requirements for a nonisolated *structure* and the forces obtained from the dynamic analysis without reduction.

**13.4.7.2 Structural Elements Above the Isolation System:** Structural *elements* above the *isolation system* shall be designed using the appropriate provisions for a nonisolated *structure* and the forces obtained from the dynamic analysis divided by a factor of  $R_f$ . The  $R_f$  factor shall be based on the type of *lateral-force-resisting system* used for the *structure* above the *isolation system*.

**13.4.7.3 Scaling of Results:** When the factored lateral shear force on structural *elements*, determined using either response spectrum or time-history analysis, is less than the minimum level prescribed by Sec. 13.4.2 and 13.4.3, all response parameters, including member forces and moments, shall be adjusted proportionally upward.

**13.4.7.4 Drift Limits:** Maximum interstory drift corresponding to the design lateral force including displacement due to vertical deformation of the *isolation system* shall not exceed the following limits:

1. The maximum interstory drift of the *structure* above the *isolation system* calculated by response spectrum analysis shall not exceed  $0.015h_{sx}$  and
2. The maximum interstory drift of the *structure* above the *isolation system* calculated by time-history analysis considering the force-deflection characteristics of nonlinear *elements* of the *lateral-force-resisting system* shall not exceed  $0.020h_{sx}$ .

Drift shall be calculated using Eq. 5.3.8.1 with the  $C_d$  factor of the isolated *structure* equal to the  $R_f$  factor defined in Sec. 13.3.4.2.

The secondary effects of the *maximum considered earthquake* lateral displacement  $\Delta$  of the *structure* above the *isolation system* combined with gravity forces shall be investigated if the interstory drift ratio exceeds  $0.010/R_f$ .

### **13.5 LATERAL LOAD ON ELEMENTS OF STRUCTURES AND NONSTRUCTURAL COMPONENTS SUPPORTED BY BUILDINGS:**

**13.5.1 General:** Parts or portions of an isolated *structure*, permanent nonstructural *components* and the attachments to them, and the attachments for permanent equipment supported by a *structure* shall be designed to resist *seismic forces* and displacements as prescribed by this section and the applicable requirements of Chapter 6.

#### **13.5.2 Forces and Displacements:**

**13.5.2.1 Components At or Above the Isolation Interface:** *Elements* of seismically isolated *structures* and nonstructural *components*, or portions thereof, that are at or above the *isolation interface* shall be designed to resist a total lateral seismic force equal to the maximum dynamic response of the *element* or *component* under consideration.

**Exception:** *Elements* of seismically isolated *structures* and nonstructural *components* or portions thereof are permitted to be designed to resist total lateral seismic force as prescribed by Eq. 5.2.6-1 or 5.2.6-2 as appropriate.

**13.5.2.2 Components Crossing the Isolation Interface:** *Elements* of seismically isolated *structures* and nonstructural *components*, or portions thereof, that cross the *isolation interface* shall be designed to withstand the *total maximum displacement*.

**13.5.2.3 Components Below the Isolation Interface:** *Elements* of seismically isolated *structures* and nonstructural *components*, or portions thereof, that are below the *isolation interface* shall be designed and constructed in accordance with the requirements of Sec. 5.2.

### **13.6 DETAILED SYSTEM REQUIREMENTS:**

**13.6.1 General:** The *isolation system* and the structural system shall comply with the material requirements of these *Provisions*. In addition, the *isolation system* shall comply with the detailed system requirements of this section and the structural system shall comply with the detailed system requirements of this section and the applicable portions of Sec. 5.2.

#### **13.6.2 Isolation System:**

**13.6.2.1 Environmental Conditions:** In addition to the requirements for vertical and lateral loads induced by wind and earthquake, the *isolation system* shall be designed with consideration given to other environmental conditions including aging effects, creep, fatigue, operating temperature, and exposure to moisture or damaging substances.

**13.6.2.2 Wind Forces:** Isolated *structures* shall resist design wind loads at all levels above the *isolation interface*. At the *isolation interface*, a wind restraint system shall be provided to limit lateral displacement in the *isolation system* to a value equal to that required between floors of the *structure* above the *isolation interface*.

**13.6.2.3 Fire Resistance:** Fire resistance rating for the *isolation system* shall be consistent with the requirements of columns, *walls*, or other such *elements* of the *structure*.

**13.6.2.4 Lateral-Restoring Force:** The *isolation system* shall be configured to produce a restoring force such that the lateral force at the *total design displacement* is at least  $0.025W$  greater than the lateral force at 50 percent of the *total design displacement*.

**Exception:** The *isolation system* need not be configured to produce a restoring force, as required above, provided the *isolation system* is capable of remaining stable under full vertical load and accommodating a *total maximum displacement* equal to the greater of either 3.0 times the *total design displacement* or  $36S_{MI}$  inches (or  $915 S_{MI}$  mm).

**13.6.2.5 Displacement Restraint:** The *isolation system* is permitted to be configured to include a displacement restraint that limits lateral displacement due to the *maximum considered earthquake* to less than  $S_{MI}/S_{DI}$  times the *total design displacement* provided that the seismically isolated *structure* is designed in accordance with the following criteria when more stringent than the requirements of Sec. 13.2:

1. *Maximum considered earthquake* response is calculated in accordance with the dynamic analysis requirements of Sec. 13.4 explicitly considering the nonlinear characteristics of the *isolation system* and the *structure* above the *isolation system*.
2. The ultimate capacity of the *isolation system* and structural *elements* below the *isolation system* shall exceed the strength and displacement demands of the *maximum considered earthquake*.
3. The *structure* above the *isolation system* is checked for stability and ductility demand of the *maximum considered earthquake*, and
4. The displacement restraint does not become effective at a displacement less than 0.75 times the *total design displacement* unless it is demonstrated by analysis that earlier engagement does not result in unsatisfactory performance.

**13.6.2.6 Vertical-Load Stability:** Each *element* of the *isolation system* shall be designed to be stable under the maximum vertical load ( $1.2D + 1.0L + |E|$ ) and the minimum vertical load ( $0.8 - |E|$ ) at a horizontal displacement equal to the *total maximum displacement*. The *dead load*,  $D$ , and the *live load*,  $L$ , are specified in Sec. 5.2.7. The seismic load,  $E$ , is given by Eq. 5.2.7-1 and 5.2.7-2 where  $S_{DS}$  in these equations is replaced by  $S_{MS}$  and the vertical load due to earthquake,  $Q_E$ , shall be based on peak response due to the *maximum considered earthquake*.

**13.6.2.7 Overturning:** The factor of safety against global structural overturning at the *isolation interface* shall not be less than 1.0 for required load combinations. All gravity and seismic loading conditions shall be investigated. *Seismic forces* for overturning calculations shall be based on the *maximum considered earthquake* and  $W$  shall be used for the vertical restoring force.

Local uplift of individual *elements* is permitted provided the resulting deflections do not cause overstress or instability of the *isolator units* or other *structure elements*.

**13.6.2.8 Inspection and Replacement:**

1. Access for inspection and replacement of all *components* of the *isolation system* shall be provided.
2. A *registered design professional* shall complete a final series of inspections or observations of *structure* separation areas and *components* that cross the *isolation interface* prior to the issuance of the certificate of occupancy for the seismically isolated *structure*. Such inspections and observations shall indicate that the conditions allow free and unhindered displacement of the *structure* to maximum design levels and that all *components* that cross the *isolation interface* as installed are able to accommodate the stipulated displacements.

3. Seismically isolated *structures* shall have a periodic monitoring, inspection and maintenance program for the *isolation system* established by the *registered design professional* responsible for the design of the system.
4. Remodeling, repair or retrofitting at the *isolation system* interface, including that of *components* that cross the *isolation interface*, shall be performed under the direction of a *registered design professional*.

**13.6.2.9 Quality Control:** A quality control testing program for *isolator units* shall be established by the *registered design professional* responsible for the structural design in accordance with Sec. 3.2.1.

### **13.6.3 Structural System:**

**13.6.3.1 Horizontal Distribution of Force:** A horizontal diaphragm or other structural *elements* shall provide continuity above the *isolation interface* and shall have adequate strength and ductility to transmit forces (due to nonuniform ground motion) from one part of the *structure* to another.

**13.6.3.2 Building Separations:** Minimum separations between the isolated *structure* and surrounding retaining *walls* or other fixed obstructions shall not be less than the *total maximum displacement*.

**13.6.3.3 Nonbuilding Structures:** These shall be designed and constructed in accordance with the requirements of Chapter 14 using *design displacements* and forces calculated in accordance with Sec. 13.3 or 13.4.

**13.7 FOUNDATIONS:** Foundations shall be designed and constructed in accordance with the requirements of Chapter 7 using design forces calculated in accordance with Sec. 13.3 or 13.4, as appropriate.

### **13.8 DESIGN AND CONSTRUCTION REVIEW:**

**13.8.1 General:** A design review of the *isolation system* and related test programs shall be performed by an independent team of *registered design professionals* in the appropriate disciplines and others experienced in seismic analysis methods and the theory and application of seismic isolation.

**13.8.2 Isolation System:** *Isolation system* design review shall include, but not be limited to, the following:

1. Review of site-specific seismic criteria including the development of site-specific spectra and ground motion time histories and all other design criteria developed specifically for the project;
2. Review of the preliminary design including the determination of the *total design displacement* of the *isolation system design displacement* and the lateral force design level;
3. Overview and observation of prototype testing (Sec. 13.9);
4. Review of the final design of the entire structural system and all supporting analyses; and
5. Review of the *isolation system* quality control testing program (Sec. 13.6.2.9).

### **13.9 REQUIRED TESTS OF THE ISOLATION SYSTEM:**

**13.9.1 General:** The deformation characteristics and damping values of the *isolation system* used in the design and analysis of seismically isolated *structures* shall be based on tests of a selected sample of the *components* prior to construction as **described** in this section.

The *isolation system components* to be tested shall include the wind-restraint system if such a system is used in the design.

The tests specified in this section are for establishing and validating the design properties of the *isolation system* and shall not be considered as satisfying the manufacturing quality control tests of Sec. 13.6.2.9.

### 13.9.2 Prototype Tests:

**13.9.2.1 General:** Prototype tests shall be performed separately on two full-size specimens (or sets of specimens, as appropriate) of each predominant type and size of *isolator unit* of the *isolation system*. The test specimens shall include the wind restraint system as well as individual *isolator units* if such systems are used in the design. Specimens tested shall not be used for construction.

**13.9.2.2 Record:** For each cycle of tests, the force-deflection behavior of the test specimen shall be recorded.

**13.9.2.3 Sequence and Cycles:** The following sequence of tests shall be performed for the prescribed number of cycles at a vertical load equal to the average *dead load* plus one-half the effects due to *live load* on all *isolator units* of a common type and size:

1. Twenty fully reversed cycles of loading at a lateral force corresponding to the wind design force;
2. Three fully reversed cycles of loading at each of the following increments of the *total design displacement*--  $0.25D_D$ ,  $0.5D_D$ ,  $1.0D_D$ , and  $1.0D_M$ ;
3. Three fully reversed cycles of loading at the *total maximum displacement*,  $1.0D_{TM}$ ; and
4.  $30S_{D1}B_D/S_{DS}$ , but not less than ten, fully reversed cycles of loading at 1 *total design displacement*,  $1.0D_{TD}$ .

If an *isolator unit* is also a vertical-load-carrying *element*, then Item 2 of the sequence of cyclic tests specified above shall be performed for two additional vertical load cases:  $1.1.2D + 0.5L + |E|$  and  $2.0.8D - |E|$  where *dead load*,  $D$ , and *live load*,  $L$ , are specified in Sec. 5.2.7. The seismic load,  $E$ , is given by Eq. 5.2.7-1 and 5.2.7-2 and the load increment due to earthquake overturning,  $Q_E$ , shall be equal to or greater than the peak earthquake vertical force response corresponding to the test displacement being evaluated. In these tests, the combined vertical load shall be taken as the typical or average downward force on all *isolator units* of a common type and size.

**13.9.2.4 Units Dependent on Loading Rates:** If the force-deflection properties of the *isolator units* are dependent on the rate of loading, then each set of tests specified in Sec. 13.9.2.3 shall be performed dynamically at a frequency equal to the inverse of the effective period,  $T_D$ .

If reduced-scale prototype specimens are used to quantify rate-dependent properties of isolators, the reduced-scale prototype specimens shall be of the same type and material and be manufactured with the same processes and quality as full-scale prototypes and shall be tested at a frequency that represents full-scale prototype loading rates.

The force-deflection properties of an *isolator unit* shall be considered to be dependent on the rate of loading if there is greater than a plus or minus 15 percent difference in the effective stiffness and the *effective damping* at the *design displacement* when tested at a frequency equal to the inverse of the



effective period,  $T_D$ , of the isolated *structure* and when tested at any frequency in the range of 0.1 to 2.0 times the inverse of the effective period,  $T_D$ , of the isolated *structure*.

**13.9.2.5 Units Dependent on Bilateral Load:** If the force-deflection properties of the *isolator units* are dependent on bilateral load, the tests specified in Sec. 13.9.2.3 and 13.9.2.4 shall be augmented to include bilateral load at the following increments of the *total design displacement*: 0.25 and 1.0, 0.50 and 1.0, 0.75 and 1.0, and 1.0 and 1.0.

**Exception:** If reduced-scale prototype specimens are used to quantify bilateral-load-dependent properties, then such specimens shall be of the same type and material and manufactured with the same processes and quality as full-scale prototypes.

The force-deflection properties of an *isolator unit* shall be considered to be dependent on bilateral load if the bilateral and unilateral force-deflection properties have greater than a plus or minus 15 percent difference in effective stiffness at the *design displacement*.

**13.9.2.6 Maximum and Minimum Vertical Load:** *Isolator units* that carry vertical load shall be statically tested for the maximum and minimum vertical load at the *total maximum displacement*. In these tests, the combined vertical load,  $1.2D + 1.0L + |E|$ , shall be taken as the maximum vertical force, and the combined vertical load,  $0.8D - |E|$ , shall be taken as the minimum vertical force, on any one isolator of a common type and size. The *dead load*,  $D$ , and *live load*,  $L$ , are specified in Sec. 5.2.7. The seismic load,  $E$ , is given by Eq. 5.2.7-1 and 5.2.7-2, where  $S_{DS}$  in these equations is replaced by  $S_{MS}$ , and the load increment due to earthquake overturning,  $Q_E$ , shall be equal to or greater than the peak earthquake vertical force response corresponding to the *maximum considered earthquake*.

**13.9.2.7 Sacrificial-Wind-Restraint Systems:** If a sacrificial-wind-restraint system is to be utilized, the ultimate capacity shall be established by test.

**13.9.2.8 Testing Similar Units:** The prototype tests are not required if an *isolator unit* is of similar dimensional characteristics and of the same type and material as a prototype *isolator unit* that has been previously tested using the specified sequence of tests.

**13.9.3 Determination of Force-Deflection Characteristics:** The force-deflection characteristics of the *isolation system* shall be based on the cyclic load tests of isolator prototypes specified in Sec. 13.9.2.

As required, the effective stiffness of an *isolator unit*,  $k_{eff}$ , shall be calculated for each cycle of loading by the equation:

$$k_{eff} = \frac{|F^+| + |F^-|}{|\Delta^+| + |\Delta^-|} \quad (13.9.3-1)$$

where  $F^+$  and  $F^-$  are the positive and negative forces at  $\Delta^+$  and  $\Delta^-$ , respectively.

As required, the *effective damping*,  $\zeta_{eff}$ , of an *isolator unit* shall be calculated for each cycle of loading by the equation:

$$k_{eff} = \frac{2}{\left[ \frac{E_{loop}}{k_{eff} (|\Delta^+| + |\Delta^-|)^2} \right]} \quad (13.9.3-2)$$

where the energy dissipated per cycle of loading,  $E_{loop}$ , and the effective stiffness,  $k_{eff}$ , shall be based on peak test displacements of  $\Delta^+$  and  $\Delta^-$ .

**13.9.4 Test Specimen Adequacy:** The performance of the test specimens shall be assessed as adequate if the following conditions are satisfied:

1. The force-deflection plots of all tests specified in Sec. 13.9.2 have a positive incremental force carrying capacity.
  - 1.1. For each increment of test displacement specified in Item 2 of Sec. 13.9.2.3 and for each vertical load case specified in Sec. 13.9.2.3:
 

There is no greater than a plus or minus 15 percent difference between the effective stiffness at each of the three cycles of test and the average value of effective stiffness for each test specimen;
  - 1.2. For each increment of test displacement specified in Item 2 of Sec. 13.9.2.3 and for each vertical load case specified in Sec. 13.9.2.3;
 

There is no greater than a 15 percent difference in the average value of effective stiffness of the two test specimens of a common type and size of the *isolator unit* over the required three cycles of test;
2. For each specimen there is no greater than a plus or minus 20 percent change in the initial effective stiffness of each test specimen over the  $30S_{DI}B_D/S_{DS}$ , but not less than 10, cycles of test specified in Item 3 of Sec. 13.9.2.3;
3. For each specimen there is no greater than a 20 percent decrease in the initial *effective damping* over for the  $30S_{DI}B_D/S_{DS}$ , but not less than 10, cycles of test specified in Item 3 of Sec. 13.9.2.3; and
4. All specimens of vertical-load-carrying *elements* of the *isolation system* remain stable up to the *total maximum displacement* for static load as prescribed in Sec. 13.9.2.6 .

### 13.9.5 Design Properties of the Isolation System:

**13.9.5.1 Maximum and Minimum Effective Stiffness:** At the *design displacement*, the maximum and minimum effectiveness stiffness of the isolated system,  $k_{Dmax}$  and  $k_{Dmin}$ , shall be based on the cyclic tests of Sec. 13.9.2.3 and calculated by the equations:

$$k_{Dmax} = \frac{\sum |F_D^+|_{max} + \sum |F_D^-|_{max}}{2D_D} \quad (13.9.5.1-1)$$

At the maximum displacement, the maximum and minimum effective stiffness of the *isolation system*,  $k_{Mmax}$  and  $k_{Mmin}$ , shall be based on the cyclic tests of Item 2 of Sec. 13.9.3 and calculated by the

$$k_{Dmin} = \frac{\sum |F_D^+|_{min} + \sum |F_D^-|_{min}}{2D_D} \quad (13.9.5.1-2)$$

equations:

$$k_{Mmax} = \frac{\sum |F_M^+|_{max} + \sum |F_M^-|_{max}}{2D_M} \quad (13.9.5.1-3)$$

$$k_{Mmin} = \frac{\sum |F_M^+|_{min} + \sum |F_M^-|_{min}}{2D_M} \quad (13.9.5.1-4)$$

The maximum effective stiffness of the *isolation system*,  $k_{Dmax}$  (or  $k_{Mmax}$ ), shall be based on forces from the cycle of prototype testing at a test displacement equal to  $D_D$  (or  $D_M$ ) that produces the largest value of effective stiffness. Minimum effective stiffness of the *isolation system*,  $k_{Dmin}$  (or  $k_{Mmin}$ ), shall be based on forces from the cycle of prototype testing at a test displacement equal to  $D_D$  (or  $D_M$ ) that produces the smallest value of effective stiffness.

For *isolator units* that are found by the tests of Sec. 13.9.3, 13.9.4 and 13.9.5 to have force-deflection characteristics that vary with vertical load, rate of loading or bilateral load, respectively, the values of  $k_{Dmax}$  and  $k_{Mmax}$  shall be increased and the values of  $k_{Dmin}$  and  $k_{Mmin}$  shall be decreased, as necessary, to bound the effects of measured variation in effective stiffness.

**13.9.5.2 Effective Damping:** At the *design displacement*, the *effective damping* of the *isolation system*,  $D_D$ , shall be based on the cyclic tests of Item 2 of Sec. 13.9.3 and calculated by the equation:

$$D_D = \frac{1}{2} \left[ \frac{\sum E_D}{k_{Dmax} D_D^2} \right] \quad (13.9.5.2-1)$$

In Eq. 13.9.5.2-1, the total energy dissipated per cycle of *design displacement* response,  $\sum E_D$ , shall be taken as the sum of the energy dissipated per cycle in all *isolator units* measured at a test displacement equal to  $D_D$ . The total energy dissipated per cycle of *design displacement* response,  $\sum E_D$ , shall be based on forces and deflections from the cycle of prototype testing at test displacement  $D_D$  that produces the smallest value of *effective damping*.

At the maximum displacement, the *effective damping* of the *isolation system*,  $D_M$ , shall be based on the cyclic tests of Item 2 of Sec. 13.9.3 and calculated by the equation:

$$M = \frac{1}{2} \left[ \frac{\sum E_M}{k_{Mmax} D_M^2} \right] \quad (13.9.5.2-2)$$

In Eq. 13.9.5.2-2, the total energy dissipated per cycle of *design displacement* response,  $\sum E_M$ , sha

taken as the sum of the energy dissipated per cycle in all *isolator units* measured at a test displacement equal to  $D_M$ . The total energy dissipated per cycle of maximum displacement response,  $\sum E_M$ , shall be based on forces and deflections from the cycle of prototype testing at test displacement  $D_M$  that produces the smallest value of *effective damping*.

## Appendix to Chapter 13

### PASSIVE ENERGY DISSIPATION SYSTEMS

Passive energy dissipation systems may be used as part of the lateral-force-resisting system of a *structure* when special detailing is used to provide results equivalent to those obtained by use of conventional structural systems. The design criteria for *structures* using passive energy dissipation systems shall be consistent with the minimum requirements of an equivalent conventional *structure* based on these *Provisions*.

The design of *structures* using passive energy dissipation systems shall be based on rational methods of analysis, incorporating the most appropriate analysis methods, including nonlinear time-history dynamic analysis. The stiffness and damping properties of damping devices shall be accurately modeled in the analysis and shall be based on tested and independently verified data from testing of such devices. Such testing shall have subjected the devices to loads, displacements, and other imposed conditions that are consistent with design conditions.

A design review of the passive energy dissipation system and related test programs shall be performed by an independent team of *registered design professionals* in the appropriate disciplines and others experienced in seismic analysis methods and the theory and application of energy dissipation systems. The scope of this design review shall be consistent with that required by these *Provisions* for the isolation system of seismically isolated *structures*.

## Chapter 14

### NONBUILDING STRUCTURE DESIGN REQUIREMENTS

#### 14.1 GENERAL:

**14.1.1 Scope:** *Nonbuilding structures* considered by these *Provisions* include all self-supporting *structures* which carry *gravity loads*, with the exception of: *buildings*, vehicular and railroad bridges, nuclear power generation plants, offshore platforms, and dams. *Nonbuilding structures* are supported by the earth or supported by other *structures*, and shall be designed and detailed to resist the minimum lateral forces specified in this chapter. Design shall conform to the applicable requirements of these *Provisions* as modified by this chapter. Nonbuilding structures that are beyond the scope of this section shall be designed in accordance with approved standards. Approved standards as referenced herein shall consist of standards approved by the authority having jurisdiction and shall be applicable to the specific type of nonbuilding structure.

The design of *nonbuilding structures* shall provide sufficient stiffness, strength, and ductility, consistent with the requirements specified herein for *buildings*, to resist the effects of seismic ground motions as represented by the following:

- a. Applicable strength and other design criteria shall be obtained from other sections of the *Provisions* or its referenced codes and standards.
- b. When applicable strength and other design criteria are not contained in or referenced by the *Provisions*, such criteria shall be obtained from approved standards. Where approved standards define acceptance criteria in terms of allowable stresses as opposed to strength, the design *seismic forces* shall be obtained from the *Provisions* and reduced by a factor of 1.4 for use with allowable stresses. Allowable stress increases used in approved standards are permitted. Detailing shall be in accordance with the approved standards.

**14.1.2 Nonbuilding Structures Supported by Other Structures:** If a *nonbuilding structure* is supported above the *base* by another *structure* and the weight of the *nonbuilding structure* is less than 25 percent of the combined weight of the *nonbuilding structure* and the supporting *structure*, the design *seismic forces* of the supported *nonbuilding structure* shall be determined in accordance with the requirements of Sec. 6.1.3.

If the weight of a *nonbuilding structure* is 25 percent or more of the combined weight of the *nonbuilding structure* and the supporting *structure*, the design *seismic forces* of the *nonbuilding structure* shall be determined based on the combined *nonbuilding structure* and supporting structural system. For supported *nonbuilding structures* that have non-rigid *component* dynamic characteristics, the combined system *R* factor shall be a maximum of 3. For supported *nonbuilding structures* that have rigid *component* dynamic characteristics (as defined in Sec. 14.2.2), the combined system *R* factor shall be the value of the supporting structural system. The supported *nonbuilding structure* and *attachments* shall be designed for the forces determined for the *nonbuilding structure* in a combined systems analysis.

**14.1.3 Architectural, Mechanical, and Electrical Components:** Architectural, mechanical, and electrical *components* supported by *nonbuilding structures* shall be designed in accordance with Chapter 6 of these *Provisions*.

**14.1.4 Loads:** The weight,  $W$ , for *nonbuilding structures* shall include all *dead loads* as defined for *structures* in Sec. 5.3.2. For purposes of calculating design *seismic forces* in *nonbuilding structures*,  $W$  also shall include all normal operating contents for items such as tanks, vessels, and bins and the contents of piping.  $W$  shall include snow and ice loads when these loads constitute 25 percent or more of  $W$ .

**14.1.5 Fundamental Period:** The fundamental period of the *nonbuilding structure* shall be determined by methods as prescribed in Sec. 5.3.3 or by other rational methods.

**14.1.6 Drift Limitations:** The drift limitations of Sec. 5.2.8 need not apply to *nonbuilding structures* if a rational analysis indicates they can be exceeded without adversely effecting structural stability. *P-delta effects* shall be considered when critical to the function or stability of the *structure*.

**14.1.7 Materials Requirements:** The requirements regarding specific materials in Chapters 8, 9, 10, 11, and 12 shall be applicable unless specifically exempted in this chapter.

## **14.2 STRUCTURAL DESIGN REQUIREMENTS:**

**14.2.1 Design Basis:** *Nonbuilding structures* having specific seismic design criteria established in approved standards shall be designed using the standards as amended herein. In addition, *nonbuilding structures* shall be designed in compliance with Sec. 14.3 and 14.4 to resist minimum seismic lateral forces which are not less than the requirements of Sec. 5.3.2 with the following additions and exceptions:

1. The response modification coefficient,  $R$ , shall be the lesser of the values given in Table 14.2.1.1 or the values in Table 5.2.2.
2. The overstrength factor,  $\phi_o$ , shall be as given in Table 14.2.1.1 or the values in Table 5.2.2..
3. The importance factor,  $I$ , shall be as given in Table 14.2.1.2 .
4. The height limitations shall be as given in Table 14.2.1.1 or the values in Table 5.2.2.
5. The vertical distribution of the lateral *seismic forces* in *nonbuilding structures* covered by this section shall be determined:
  - a. In accordance with the requirements of Sec. 5.3.4 or
  - b. In accordance with the procedures of Sec. 5.4 or
  - c. In accordance with an approved standard applicable to the specific *nonbuilding structure*.
6. Irregular *structures* per Sec. 5.2.3 at sites where the seismic coefficient  $S_{DS}$  is greater than or equal to 0.50 that cannot be modeled as a single mass shall use the procedures of Sec. 5.4.
7. Where an approved standard provides a basis for the earthquake resistant design of a particular type of *nonbuilding structure* such a standard may be used subject to the following limitations:
  - a. The seismic ground acceleration and seismic coefficient shall be in conformance with the requirements of Sec. 4.1 and 4.2, respectively.

- b. The values for total lateral force and total *base* overturning moment used in design shall not be less than 80 percent of the *base shear* value and overturning moment, each adjusted for the effects of soil-*structure* interaction that would be obtained using these *Provisions*.
8. The *base shear* is permitted to be reduced in accordance with Sec. 5.5.2.1 to account for the effects of soil-*structure* interaction. In no case shall the reduced *base shear*,  $V$ , be less than  $0.7V$ .

**14.2.1.1 Seismic Factors:**

**TABLE 14.2.1.1 Seismic Coefficients for Nonbuilding Structures**

Nonbuilding Structure Type	R	o	C <sub>d</sub>	Structural System and Height Limits (ft) <sup>c</sup>			
				Seismic Design Category			
				A & B	C	D	E & F
Nonbuilding frame systems: Concentric Braced Frames of Steel Special Concentric Braced Frames of Steel	See Table 5.2.2			NL NL	NL NL	NL NL	NL NL
Moment Resisting Frame Systems: Special Moment Frames of Steel Ordinary Moment Frames of Steel Special Moment Frames of Concrete Intermediate Moment Frames of Concrete Ordinary Moment Frames of Concrete	See Table 5.2.2			NL NL NL NL NL	NL NL NL NL 50	NL 50 NL 50 NP	NL 50 NL 50 NP
Steel <i>Storage Racks</i>	4	2	3-1/2	NL	NL	NL	NL
Elevated tanks, vessels, bins, or hoppers <sup>a</sup> :							
On braced legs	3	2	2-1/2	NL	NL	NL	NL
On unbraced legs	3	2	2-1/2	NL	NL	NL	NL
Irregular braced legs single pedestal or skirt supported	2	2	2	NL	NL	NL	NL
Welded steel	2	2	2	NL	NL	NL	NL
Concrete	2	2	2	NL	NL	NL	NL
Horizontal, saddle supported welded steel vessels	3	2	2-1/2	NL	NL	NL	NL
Tanks or vessels supported on structural towers similar to buildings	3	2	2	NL	NL	NL	NL



Nonbuilding Structure Type	R	o	C <sub>d</sub>	Structural System and Height Limits (ft) <sup>c</sup>			
				Seismic Design Category			
				A & B	C	D	E & F
Flat bottom, ground supported tanks, or vessels: Anchored (welded or bolted steel)	3	2	2-1/2	NL	NL	NL	NL
Unanchored (welded or bolted steel)	2-1/2	2	2	NL	NL	NL	NL
Reinforced or prestressed concrete: Tanks with reinforced nonsliding <i>base</i>	2	2	2	NL	NL	NL	NL
Tanks with anchored flexible <i>base</i>	3	2	2	NL	NL	NL	NL
Tanks with unanchored and unconstrained: Flexible <i>base</i>	1-1/2	1-1/2	1-1/2	NL	NL	NL	NL
Other material	1 -/2	1-1/2	1-1/2	NL	NL	NL	NL
Cast-in-place concrete silos, stacks, and chimneys having <i>walls</i> continuous to the foundation	3	1-3/4	3	NL	NL	NL	NL
All other reinforced masonry <i>structures</i>	3	2	2-1/2	NL	NL	50	50
All other nonreinforced masonry <i>structures</i>	1-1/4	2	1-1/2	NL	50	50	50
All other steel and reinforced concrete distributed mass cantilever <i>structures</i> not covered herein including stacks, chimneys, silos, and skirt-supported vertical vessels	3	2	2-1/2	NL	NL	NL	NL
Trussed towers (freestanding or guyed), guyed stacks and chimneys	3	2	2-1/2	NL	NL	NL	NL
Cooling towers: Concrete or steel	3-1/2	1-3/4	3	NL	NL	NL	NL
Wood frame	3-1/2	3	3	NL	NL	50	50
Electrical transmission towers, substation wire support <i>structures</i> , distribution <i>structures</i>							
Truss: Steel and aluminum	3	1-1/2	3	NL	NL	NL	NL
Pole: Steel	1-1/2	1-1/2	1-1/2	NL	NL	NL	NL
Wood	1-1/2	1-1/2	1-1/2	NL	NL	NL	NL
Concrete	1-1/2	1-1/2	1-1/2	NL	NL	NL	NL
Frame: Steel	3	1-1/2	1-1/2	NL	NL	NL	NL
Wood	2-1/2	1-1/2	1-1/2	NL	NL	NL	NL
Concrete	2	1-1/2	1-1/2	NL	NL	NL	NL

Nonbuilding Structure Type	R	o	C <sub>d</sub>	Structural System and Height Limits (ft) <sup>c</sup>			
				Seismic Design Category			
				A & B	C	D	E & F
Telecommunication towers							
Truss: Steel	3	1-1/2	3	NL	NL	NL	NL
Pole: Steel	1-1/2	1-1/2	1-1/2	NL	NL	NL	NL
Wood	1-1/2	1-1/2	1-1/2	NL	NL	NL	NL
Concrete	1-1/2	1-1/2	1-1/2	NL	NL	NL	NL
Frame: Steel	3	1-1/2	1-1/2	NL	NL	NL	NL
Wood	2-1/2	1-1/2	1-1/2	NL	NL	NL	NL
Concrete	2	1-1/2	1-1/2	NL	NL	NL	NL
Amusement <i>structures</i> and monuments	2	2	2	NL	NL	NL	NL
Inverted pendulum type <i>structures</i> (not elevated tank) <sup>b</sup>	2	2	2	NL	NL	NL	NL
Signs and billboards	3-1/2	1-3/4	3	NL	NL	NL	NL
All other self-supporting <i>structures</i> , tanks or vessels not covered above or by approved standards	1-1/4	2	2-1/2	NL	50	50	50

<sup>a</sup>Support towers similar to building type *structures*, including those with irregularities (see Sec. 5.2.3 of these *Provisions* for definition of irregular *structures*) shall comply with the requirements of Sec. 5.2.6.

<sup>b</sup>Light posts, stoplight, etc.

<sup>c</sup>Height shall be measured from the base.

NL = No limit.

**14.2.1.2 Importance Factors and Seismic Use Group Classifications:** The importance factor (*I*) and *seismic use group* for *nonbuilding structures* are based on the relative hazard of the contents, and the function. The value of *I* shall be the largest value determined by the approved standards, or the largest value as selected from Table 14.2.1.2.

**TABLE 14.2.1.2**  
**Importance Factor (*I*) and Seismic Use Group Classification for Nonbuilding Structures**

Importance Factor	<i>I</i> = 1.0	<i>I</i> = 1.25	<i>I</i> = 1.5
Seismic Use Group	I	II	III
Hazard	H - I	H - II	H - III
Function	F - I	F - II	F - III

- H - I The stored product is biologically or environmentally benign; low fire or low physical hazard.
- H - II The stored product is rated low explosion, moderate fire, or moderate physical as determined by the authority having jurisdiction.
- H - III The stored product is rated high or moderate explosion hazard, high fire hazard, or high physical hazard as determined by the authority having jurisdiction.
- F - I *Nonbuilding structures* not classified as F - III.
- F - II Not applicable.
- F - III *Seismic use group III nonbuilding structures* or designated ancillary *nonbuilding structures* (such as communication towers, fuel storage tanks, cooling towers, or electrical substation *structures*) required for operation of *Seismic Use Group III structures*.

**14.2.2 Rigid Nonbuilding Structures:** *Nonbuilding structures* that have a fundamental period,  $T$ , less than 0.06 sec, including their anchorages, shall be designed for the lateral force obtained from the following:

$$V = 0.30S_{DS}WI \quad (14.2.2)$$

where:

- $V$  = the total design lateral seismic *base shear* force applied to a *nonbuilding structure*,
- $S_{DS}$  = the site design response acceleration as determined from Sec. 4.2.2,
- $W$  = *nonbuilding structure* operating weight.
- $I$  = the importance factor as determined from Table 14.2.1.2.

The force shall be distributed with height in accordance with Sec. 5.3.4.

**14.2.3 Deflection Limits and Structure Separation:** Deflection limits and *structure* separations shall be determined in accordance with these *Provisions* unless specifically amended in this chapter.

### **14.3 NONBUILDING STRUCTURES SIMILAR TO BUILDINGS:**

**14.3.1 General:** *Nonbuilding structures* that have structural systems that are designed and constructed in a manner similar to buildings and have a dynamic response similar to building *structures* shall be designed similar to building *structures* and in compliance with these *Provisions* with exceptions as contained in this section.

This general category of *nonbuilding structures* shall be designed in accordance with Sec. 4.4 and Sec. 14.2.

The lateral force design procedure for *nonbuilding structures* with structural systems similar to building *structures* (those with structural systems listed in Table 5.2.2) shall be selected in accordance with the force and detailing requirements of Sec. 5.2.1.

The combination of load effects,  $E$ , shall be determined in accordance with Sec. 5.2.7.

### 14.3.2 Pipe Racks:

**14.3.2.1 Design Basis:** Pipe racks supported at the base shall be designed to meet the force requirements of Sec. 5.3 or 5.4.

*Displacements* of the pipe rack and potential for interaction effects (pounding of the piping system) shall be considered using the amplified deflections obtained from the following formula:

$$x = \frac{C_d \cdot x_e}{I} \quad (14.3.2.1)$$

where:

- $C_d$  = The deflection amplification factor in Table 14.2.1.1,  
 $x_e$  = The deflections determined using the prescribed seismic design forces of the *Provisions*, and  
 $I$  = The importance factor determined from Table 14.2.1.2.

**Exception:** The importance factor,  $I$ , shall be determined from Table 14.2.1.2 for the calculation of  $x_e$ .

See Sec. 3.3.11 for the design of piping systems and their *attachments*. Friction resulting from *gravity loads* shall not be considered to provide resistance to *seismic forces*.

**14.3.3 Steel Storage Racks:** This section applies to steel *storage racks* supported at the *base*. *Storage racks* shall be designed, fabricated, and installed in accordance with Ref. 3-13 and the requirements of this section. Steel *storage racks* not supported at or below *grade* shall be designed in accordance with Sec. 6.2.9.

**14.3.3.1 General Requirements:** Steel *storage racks* shall satisfy the force requirements of this section.

**Exception:** Steel *storage racks* supported at the *base* are permitted to be designed as *structures* with an  $R$  of 4, provided that the requirements of Chapter 2 are met. Higher values of  $R$  are permitted to be used when justified by test data approved in accordance with Sec. 1.2.6 or when the detailing requirements of Chapter 5 and 10 are met. The importance factor  $I$  shall be taken equal to the  $I_p$  values in accordance with Sec. 6.1.5

**14.3.3.2 Operating Weight:** Steel *storage racks* shall be designed for each of the following conditions of operating weight,  $W$  or  $W_p$ .

- a. Weight of the rack plus every storage level loaded to 67 percent of its rated load capacity.
- b. Weight of the rack plus the highest storage level only loaded to 100 percent of its rated load capacity.

The design shall consider the actual height of the center of mass of each storage load *component*.

**14.3.3.3 Vertical Distribution of Seismic Forces:** For all steel *storage racks*, the vertical distribution of *seismic forces* shall be as specified in Sec. 5.3.4 and in accordance with the following:

- a. The *base shear*,  $V$ , of the typical *structure* shall be the *base shear* of the steel *storage rack* when loaded in accordance with Sec. 14.3.3.2.
- b. The *base* of the *structure* shall be the floor supporting the steel *storage rack*. Each steel storage level of the rack shall be treated as a level of the *structure*, with heights  $h_p$  and  $h_x$  measured from the *base* of the *structure*.
- c. The factor  $k$  may be taken as 1.0.
- d. The factor  $I$  shall be in accordance with Sec. 6.1.5.

**14.3.3.4 Seismic Displacements:** Steel *storage rack* installations shall accommodate the seismic *displacement* of the *storage racks* and their contents relative to all adjacent or attached *components* and *elements*. The assumed total relative *displacement* for *storage racks* shall be not less than 5 percent of the height above the base unless a smaller value is justified by test data or analysis approved in accordance with Sec. 1.5.

#### **14.3.4 Electrical Power Generating Facilities:**

**14.3.4.1 General:** Electrical power generating facilities are power plants that generate electricity by steam turbines, combustion turbines, diesel generators or similar turbo machinery.

**14.3.4.2 Design Basis:** Electrical power generating facilities shall be designed using these *Provisions* and the appropriate factors contained in Sec. 14.2.

#### **14.3.5 Structural Towers for Tanks and Vessels:**

**14.3.5.1 General:** Structural towers which support tanks and vessels shall be designed to meet the provisions of Sec 14.1.2. In addition, the following special considerations shall be included:

- a. The distribution of the lateral *base shear* from the tank or vessel onto the supporting *structure* shall consider the relative stiffness of the tank and resisting structural *elements*.
- b. The distribution of the vertical reactions from the tank or vessel onto the supporting *structure* shall consider the relative stiffness of the tank and resisting structural *elements*. When the tank or vessel is supported on grillage beams, the calculated vertical reaction due to weight and overturning shall be increased at least 20 percent to account for nonuniform support. The grillage beam and vessel attachment shall be designed for this increased design value.
- c. Seismic *displacements* of the tank and vessel shall consider the *deformation* of the support *structure* when determining *P-delta effects* or evaluating required clearances to prevent pounding of the tank on the *structure*.

#### **14.3.6 Piers and Wharves:**

**14.3.6.1 General:** Piers and wharves are *structures* located in waterfront areas that project into a body of water or parallel the shore line.

**14.3.6.2 Design Basis:** Piers and wharves shall be designed to comply with these *Provisions* and approved standards. *Seismic forces* on *elements* below the water level shall include the inertial force of the mass of the displaced water. The additional seismic mass equal to the mass of the displaced water shall be included as a lumped mass on the submerged *element*, and shall be added to the calculated

*seismic forces* of the pier or wharf *structure*. Seismic dynamic forces from the soil shall be determined by the registered design professional.

The design shall account for the effects of liquefaction on piers and wharfs as required.

#### **14.4 NONBUILDING STRUCTURES NOT SIMILAR TO BUILDINGS:**

**14.4.1 General:** *Nonbuilding structures* that have structural systems that are designed and constructed in a manner such that the dynamic response is not similar to buildings shall be designed in compliance with these *Provisions* with exceptions as contained in this section.

This general category of *nonbuilding structures* shall be designed in accordance with these *Provisions* and the specific applicable approved standards. Loads and load distributions shall not be less than those determined in these *Provisions*.

The combination of load effects,  $E$ , shall be determined in accordance with Sec. 5.2.6.2.

**Exception:** The redundancy/reliability factor,  $\phi$ , per Sec. 5.2.4 shall be taken as 1.

#### **14.4.2 Earth Retaining Structures:**

**14.4.2.1 General:** This section applies to all earth retaining *walls*. The applied *seismic forces* shall be determined in accordance with Sec. 7.5.1 with a geotechnical analysis prepared by a *registered design professional*.

#### **14.4.3 Tanks and Vessels:**

**14.4.3.1 General:** This section applies to all tanks and vessels storing liquids, gases, and granular solids supported at the base. Tanks and vessels covered herein include reinforced concrete, prestressed concrete, steel, and fiber-reinforced plastic materials. Tanks supported on elevated levels in buildings shall be designed in accordance with Sec. 6.3.9.

**14.4.3.2 Design Basis:** Tanks and vessels shall be designed in accordance with these *Provisions* and shall be designed to resist seismic lateral forces determined from a substantiated analysis using approved standards.

**14.4.3.3 Additional Requirements:** In addition, for sites where  $S_{DS}$  is greater than 0.60, flat-bottom tanks designated with an  $I_p$  greater than 1.0 or tanks greater than 20 ft (6.2 m) in diameter or tanks that have a height-to-diameter ratio greater than 1.0 shall also be designed to meet the following additional requirements:

1. Sloshing effects shall be calculated and provided for in the design, fabrication, and installation.
2. Piping connections to steel flat-bottom storage tanks shall consider the potential uplift of the tank *wall* during earthquakes. Unless otherwise calculated, the following *displacements* shall be assumed for all side-*wall* connections and bottom penetrations:
  - a. Vertical *displacement* of 2 in. (51 mm) for anchored tanks.
  - b. Vertical *displacement* of 12 in. (305 mm) for unanchored tanks, and
  - c. Horizontal *displacement* of 8 in. (203 mm) for unanchored tanks with a diameter of 40 ft (12.2 m) or less.

#### **14.4.4 Electrical Transmission, Substation, and Distribution Structures:**

**14.4.4.1 General:** This section applies to electrical transmission, substation, and distribution *structures*.

**14.4.4.2 Design Basis:** Electrical transmission, substation wire support and distribution *structures* shall be designed to resist seismic lateral forces determined from a substantiated analysis using approved standards.

#### **14.4.5 Telecommunication Towers:**

**14.4.5.1 General:** This section applies to telecommunication towers.

**14.4.5.2 Design Basis:** Self-supporting and guyed telecommunication towers shall be designed to resist seismic lateral forces determined from a substantiated analysis using approved standards.

#### **14.4.6 Stacks and Chimneys:**

**14.4.6.1 General:** Stacks and chimneys are permitted to be either lined or unlined, and shall be constructed from concrete, steel, or masonry.

**14.4.6.2 Design Basis:** Steel stacks, concrete stacks, steel chimneys, concrete chimneys, and liners shall be designed to resist seismic lateral forces determined from a substantiated analysis using approved standards. Interaction of the stack or chimney with the liners shall be considered. A minimum separation shall be provided between the liner and chimney equal to  $C_d$  times the calculated differential lateral drift.

#### **14.4.7 Amusement Structures:**

**14.4.7.1 General:** Amusement *structures* are permanently fixed *structures* constructed primarily for the conveyance and entertainment of people.

**14.4.7.2 Design Basis:** Amusement *structures* shall be designed to resist seismic lateral forces determined from a substantiated analysis using approved standards.

#### **14.4.8 Special Hydraulic Structures:**

**14.4.8.1 General:** Special hydraulic *structures* are *structures* that are contained inside liquid containing *structures*. These *structures* are exposed to liquids on both *wall* surfaces at the same head elevation under normal operating conditions. Special hydraulic *structures* are subjected to out of plane forces only during an earthquake when the *structure* is subjected to differential hydrodynamic fluid forces. Examples of special hydraulic *structures* include: separation *walls*, baffle *walls*, weirs, and other similar *structures*.

**14.4.8.2 Design Basis:** Special hydraulic *structures* shall be designed for out-of-phase movement of the fluid. Unbalanced forces from the motion of the liquid must be applied simultaneously "in front of" and "behind" these *elements*.

*Structures* subject to hydrodynamic pressures induced by earthquakes shall be designed for rigid body and sloshing liquid forces and their own inertia force. The height of sloshing shall be determined and compared to the freeboard height of the *structure*.

Interior *elements*, such as baffles or roof supports, also shall be designed for the effects of unbalanced forces and sloshing.

#### **14.4.9 Buried Structures:**

**14.4.9.1 General:** Buried *structures* are subgrade *structures* such as tanks, tunnels, and pipes. Buried *structures* that are designated as *Seismic Use Group II* or *III*, or are of such a size or length to warrant special seismic design as determined by the registered design professional shall be identified in the geotechnical report.

**14.4.9.2 Design Basis:** Buried *structures* shall be designed to resist minimum seismic lateral forces determined from a substantiated analysis using approved standards. Flexible couplings shall be provided for buried *structures* requiring special seismic considerations where changes in the support system, configuration, or soil condition occur.

**14.4.10 Inverted Pendulums:** These *structures* are a special category of *structures* which support an elevated lumped mass, and exclude water tanks.



## Appendix to Chapter 14

**PREFACE:** The *NEHRP Recommended Provisions* is a resource document not a model code. The following sections originally were intended to be part of the *nonbuilding structures* chapter of these *Provisions*. The Provisions Update Committee felt that given the complexity of the issues, the varied nature of the resource documents, and the lack of supporting consensus resource documents, time did not allow a sufficient review of the proposed sections required for inclusion into the main body of the chapter.

The Nonbuilding Structures Technical Subcommittee, however, expressed that what is presented herein represents the current industry accepted design practice within the engineering community that specializes in these types of *nonbuilding structures*.

The sections are included here so that the design community specializing in these *nonbuilding structures* can have the opportunity to gain a familiarity with the concepts, update their standards, and send comments on this appendix to the BSSC.

It is hoped that the various consensus design standards will be updated to include the design and construction methodology presented in this Appendix. It is also hoped that industry standards that are currently not consensus documents will endeavor to move their standards through the consensus process facilitating building code inclusion.

### A14.1 REFERENCES AND STANDARDS:

**A14.1.1 Standards:** The following references are consensus standards and are to be considered part of this appendix to the extent referred to in this chapter:

- Ref. A14-1 American Petroleum Institute (API) Standard, ANSI /API 650-1992, *Welded Steel Tanks For Oil Storage*, 1988.
- Ref. A14-2 American Society of Mechanical Engineers (ASME), *Boiler And Pressure Vessel Code*, including addenda through 1993
- Ref. A14-3 American Society of Mechanical Engineers (ASME), ANSI/ASME STS-1-1992, *Steel Stacks*.
- Ref. A14-4 American Water Works Association (AWWA) Standard, ANSI/AWWA D100-96, AWS D5.2-96, *Welded Steel Tanks For Water Storage*, 1996.
- Ref. A14-9 Rack Manufacturers Institute (RMI), *Specification for the Design, Testing, and Utilization of Industrial Steel Storage Racks*, 1990.
- Ref. A14-14 American Association of State Highway and Transportation Officials, *Standard Specifications for Highway Bridges*, 1996.
- Ref. A14-15 ASTM F1159-92, "Standard Practice for the Design and Manufacture of Amusement Rides and Devices".
- Ref. A14-16 American Water Works Association (AWWA) Standard, ANSI/AWWA D110-95, *Wire-and Strand-Wound Circular Prestressed Concrete Water Tanks*, 1995.

- Ref. A14-17 American Society of Civil Engineers, (ASCE), ANSI/ASCE 10-90, *Design of Latticed Transmission Structures*, New York, NY, 1991.
- Ref. A14-19 American Society of Civil Engineers, (ASCE) Standard 7, *Minimum Design Loads for Buildings and Other Structures*, 1995.
- Ref. A14-22 *National Electrical Safety Code*, Institute of Electrical and Electronics Engineers, New Jersey, 1997 (Tentative).
- Ref A14-26 ASTM C 1298-95, *Standard Guide for Design and Construction of Brick Liners for Industrial Chimneys*.
- Ref A14-27 American Concrete Institute, (ACI), ANSI/ACI 349-90 *Code Requirements for Nuclear Safety Related Structures - Appendix B*, 1990.
- Ref A14-28 American Petroleum Institute (API) Standard, ANSI/API 620-1992 - *Design and Construction of Large, Welded, Low Pressure Storage Tanks*.
- Ref A14-29 American Water Works Association (AWWA) Standard ANSI/AWWA D103-97, (Tentative) *Factory-Coated Bolted Steel Tanks for Water Storage*, 1996.
- Ref A14-30 American Water Works Association (AWWA) Standard, ANSI/AWWA D115-95, *Circular Prestressed Concrete Tanks With Circumferential Tendons*, 1995.
- Ref A14-32 National Fire Protection Association (NFPA) Standard, ANSI/NFPA 58-1995, *Storage and Handling of Liquefied Petroleum Gas*.
- Ref A14-33 National Fire Protection Association (NFPA) Standard, ANSI/NFPA 59-1995, *Storage and Handling of Liquefied Petroleum Gases at Utility Gas Plants* .
- Ref A14-34 National Fire Protection Association (NFPA) Standard, ANSI/NFPA 59A-1994, *Production, Storage and Handling of Liquefied Natural Gas (LNG)*.
- Ref A14-36 National Fire Protection Association (NFPA) Standard, ANSI/NFPA 30-1993, *Flammable and Combustible Liquids Code*, 1993.
- Ref A14-45 American Petroleum Institute, (API), Standard ANSI/API 2510-1995, "*Design and Construction of Liquefied Petroleum Gas Installation*", Seventh Edition, May 1995..
- Ref A14-46 American National Standards Institute, (ANSI), ANSI K61.1, "*Safety Requirements for the Storage and Handling of Anhydrous Ammonia*".

**A14.1.2 Industry Standards:** The following references are standards developed within the industry and represent acceptable industry practice for design and construction and are applicable to the extent referred to in this appendix:

- Ref. A14-5 Institute of Electrical and Electronic Engineers (IEEE), IEEE 693 (Tentative), *Recommended Practices for Seismic Design of Substations*, Power Engineering Society, Piscataway, New Jersey, 1997.
- Ref. A14-6 Manufacturers Standardization Society of the Valve and Fitting Industry (MSS), SP-58, *Pipe Hangers and Supports Materials, Design, and Manufacture*, 1988.

- 
- Ref. A14-10 American Concrete Institute (ACI), ACI 350-96, (Tentative) *Environmental Concrete Engineering Structures*, 1996.
- Ref. A14-13 American Concrete Institute, (ACI), ACI 307, Standard Practice for the Design and Construction of Cast-In-Place Reinforced Concrete Chimneys, 1995 .
- Ref. A14-18 American Society of Civil Engineers, (ASCE), ASCE Manual 72, *Tubular Pole Design Standard*, New York, NY, 1991.
- Ref. A14-25 Telecommunications Industry Association, (TIA), TIA/EIA 222F *Structural Standards for Steel Antenna Towers and Antenna Supporting Structures*, 1996.
- Ref A14-35 U.S. Department of Transportation (DOT) Pipeline Safety Regulations, Title 49CFR Part 193.
- Ref A14-37 American Concrete Institute, (ACI), ACI 313-91, Standard Practice for the Design and Construction of Concrete Silos and Stacking Tubes for Storing Granular Materials, 1991.
- Ref A14-38 American Society of Civil Engineers, (ASCE), *Guidelines for the Seismic Design of Oil and Gas Pipeline Systems*, New York, NY, 1991.
- Ref A14-44 American Petroleum Institute, (API), 2508, "*Design and Construction of Ethane and Ethylene Installations at Marine and Pipeline Terminals, Natural Gas Processing Plants, Refineries, Petrochemical Plants and Tank Farms*", Second Edition, November 1995.
- Ref. A14-49 Institute of Electrical and Electronic Engineers (IEEE), IEEE Standard 751, *Trial-Use Design Guide for Wood Transmission Structures*, Power Engineering Society, Piscataway, New Jersey, 1991.

**A14.1.3 General References:** The following references are general references applicable to the structural design and construction practices of particular *nonbuilding structures* and represent industry design practice to the extent referred to in this appendix:

- Ref. A14-7 Naval Civil Engineering Laboratory R-939 "The Seismic Design of Waterfront Retaining Structures"
- Ref. A14-8 Naval Facilities Engineering Command (NAVFAC) DM-25.1 "Piers and Wharves".
- Ref. A14-11 Army TM 5-809-10, Navy NAVFAC P-355, Air Force AFM 88-3, Chapter 13, Seismic Design for Buildings, 1992
- Ref. A14-12 Tubular Steel Structures by M.S. Troitsky, 1990.
- Ref. A14-20 American Society of Civil Engineers, (ASCE) ASCE Manual 74, *Guidelines for Electrical Transmission Line Structural Loading*, New York, NY, 1991.
- Ref. A14-21 Rural Electrification Administration, (REA), *Bulletin 65-1, Design Guide for Rural Substations*, 1978.
- Ref. A14-23 American Society of Civil Engineers, (ASCE) *Guide for the Design of Guyed Transmission Structures*, New York, NY.
-

- Ref. A14-24 American Society of Civil Engineers, (ASCE) , *Substation Structure Design Guide*, New York, NY, 1991.
- Ref A14-31 Gaylord and Gaylord, “Design of Steel Bins for Storage of Bulk Solids”, Prentice Hall, 1984.
- Ref A14-39 American Society of Civil Engineers, (ASCE) Petrochemical Energy Committee Task Committee on Seismic Evaluation and Design of Petrochemical Facilities, *Guidelines for Seismic Evaluation and Design of Petrochemical Facilities*, New York, NY.
- Ref A14-40 Wozniak, R. S. and Mitchell, W. W., “*Basis of Seismic Design Provisions for Welded Steel Oil Storage Tanks*”, 1978 Proceedings -- Refining Dept, Vol 57, American Petroleum Institute, Washington, D.C., May 9, 1978
- Ref A14-41 Zick, L.P., “*Stresses in Large Horizontal Cylindrical Pressure Vessels on Two Saddle Supports*”, Steel Plate Engineering Data, Vol 1and2, American Iron and Steel Institute, Dec 1992.
- Ref A14-43 Housner, G.W. “*Earthquake Pressures in Fluid Containers*”, California Institute of Technology (1954).
- Ref. A14-47 Rural Electrical Administration, (REA), Bulletin 1724E-200, *Design Manual for High Voltage Transmission Lines*, 1992.
- Ref. A14-48 Rural Electrical Administration, (REA), Bulletin 160-2, *Mechanical Design Manual for Overhead Distribution Lines*, 1982.

**A14.2 INDUSTRY DESIGN STANDARDS AND RECOMMENDED PRACTICE:** The following standards and references are considered industry generally accepted design and construction practice.

**TABLE A14.2 Standards, Industry Standards, and References**

<b>Application</b>	<b>Standard or Reference</b>
Steel <i>Storage Racks</i>	Ref. A 14-9
Piers and Wharves	Ref. A14-7, Ref. A14-8
Welded Steel Tanks for Water Storage	Ref. A14-4
Welded Steel Tanks for Petroleum and Petrochemical Storage	Ref. A14-1, Ref. A14-28
Bolted Steel Tanks for Water Storage	Ref. A14-29
Concrete Tanks for Water Storage	Ref. A14-30, Ref. A14-16
Pressure Vessels	Ref. A14-2
Refrigerated Liquids Storage:	
Liquid Oxygen, Nitrogen and Argon	Ref. A14-33
Liquefied Natural Gas (LNG)	Ref. A14-34, Ref. A14-35, Ref. A14-36
LPG (Propane, Butane, etc.)	Ref. A14-33, Ref. A14-36, Ref. A14-45
Ammonia	Ref. A14-46
Ethylene	Ref. A14-44
Concrete silos and stacking tubes	Ref. A14-37
Petrochemical <i>structures</i>	Ref. A14-38
Impoundment dikes and <i>walls</i> :	
Hazardous Materials	Ref. A14-46
Flammable Materials	Ref. A14-36
Liquefied Natural Gas	Ref. A14-34, Ref. A14-35
Electrical Transmission, Substation, and Distribution <i>Structures</i>	Ref. A14-5, Ref. A14-17, Ref. A14-18, Ref. A14-20, Ref. A14-21, Ref. A14-22, Ref. A14-23, Ref. A14-24, Ref. A14-47, Ref. A14-48, Ref. A14-49
Telecommunications <i>structures</i>	Ref. A14-19, Ref. A14-25
Cast-in-place concrete stacks and chimneys	Ref. A14-13
Steel stacks and chimneys	Ref. A14-3
Guyed steel stacks and chimneys	Ref. A14-3, Ref. A14-12
Brick masonry liners for stacks and chimneys	Ref. A14-26
Amusement <i>structures</i>	Ref. A14-15

**A14.3 TANKS AND VESSELS:**

**A14.3.1 General:** Tanks and vessels storing liquids, gases, and granular solids shall be designed to meet the requirements of the applicable approved standards shown in Table 14.1.9 and the Chapter 2 of these *Provisions* as defined in this section.

Tanks and vessels covered here include steel and concrete (reinforced concrete or prestressed)

**A14.3.1.1 Strength and Ductility:** Structural *components* and members that are part of the lateral support system shall be designed to provide the following:

- a. Connections and *attachments* for anchorage and other lateral force resisting *components* shall be designed to develop the strength of the connected member (e.g., minimum published yield strength,  $F_y$  in direct tension, plastic bending moment), or  $\phi$  times the calculated *element* design load.
- b. Penetrations, manholes, and openings in shell *components* shall be designed to maintain the capacity and stability of the shell to carry tensile and compressive membrane shell forces.
- c. Support towers for tanks and vessels with irregular bracing, unbraced panels, asymmetric bracing, or concentrated masses shall be designed using the provisions of Sec. 5.2.3 for irregular *structures*. Support towers using chevron or eccentric braced framing shall comply with the requirements of Sec. 5). Support towers using tension only bracing shall be designed such that the full cross section of the tension *element* can yield during overload conditions.
- d. Compression struts that resist the reaction forces from tension braces shall be designed to resist the lesser of the yield load of the brace ( $A_g F_y$ ), or  $\phi$  times the calculated tension load in the brace.
- e. The vessel stiffness relative to the support system (foundation, support tower, skirt, etc.) shall be considered in determining forces in the vessel, the resisting *components* and the connections.
- f. For concrete liquid-containing *structures*, system ductility and energy dissipation under nonfactored loads shall not be allowed to be achieved by excursions into the inelastic range to such a degree as to jeopardize the serviceability of the *structure*. Stiffness degradation and energy dissipation shall be allowed to be obtained either through limited microcracking, or by means of lateral-force resistance mechanisms that dissipate energy without damaging the *structure*.

**A14.3.1.2 Flexibility of Piping Attachments:** Piping systems connected to tanks and vessels shall consider the potential movement of the connection point during earthquakes and provide sufficient flexibility to avoid release of the product by failure of the piping system. The piping system and supports shall be designed so as not to impart significant mechanical loading on the attachment to the tank or vessel shell. Mechanical devices which add flexibility such as bellows, expansion *joints*, and other flexible apparatus can be used when they are designed for seismic loads and *displacements*.

Unless otherwise calculated, the minimum *displacements* in Table 14.4.3.1.2 shall be assumed. For attachment points located above the support or foundation elevation, the *displacements* in Table 14.4.3.1.2 shall be magnified to account for drift of the tank and vessel.

**TABLE A14.3.1.2 Minimum Displacements for Piping Attachments**

<b>Anchored Tanks or Vessels</b>	<b>Displacements (inches)</b>
Vertical <i>displacement</i> relative to support or foundation	2
Horizontal ( radial and tangential ) relative to support or foundation	0.5
<b>Unanchored Tanks or Vessels (at grade)</b>	
Vertical <i>displacement</i> relative to support or foundation If designed to meet approved standard.	6
If designed for seismic loads per these provisions but not covered by an approved standard	12
For tanks and vessels with a diameter <40 ft, horizontal (radial and tangential) relative to support or foundation	8

When the elastic *deformations* are calculated, the minimum design *displacements* for piping *attachments* shall be the calculated *displacements* at the point of attachment increased by the amplification factor  $C_a$ .

When  $S_{DS} \leq 0.1$ , the values in Table A14.3.1.2 may be reduced to 2/3 of the values shown.

The values given in Table A14.3.1.2 do not include the influence of relative movements of the foundation and piping anchorage points due to foundation movements (e.g., settlement, seismic *displacements*). The effects of the foundation movements shall be included in the piping system design and the determination of the mechanical loading on the tank, and the total movement requirements for mechanical devices intended to add flexibility.

**A14.3.1.3 Anchorage:** Tanks and vessels at *grade* are permitted to be designed without anchorage when they meet the requirements for unanchored tanks in the approved standard. Tanks and vessels supported above *grade* on structural towers or building *structures* shall be anchored to the supporting *structure*.

The following special detailing requirements shall apply to steel tank anchor bolts in seismic regions where  $S_{DS} > 0.5$ , or where the *structure* is classified as *Seismic Use Group III*.

- a. Hooked anchor bolts or other anchorage systems based solely on bond or mechanical friction shall not be used.
- b. When anchorage is required, the anchor embedment into the foundation shall be designed to develop the minimum published tensile yield strength of the anchor.

### **A14.3.2 Ground-Supported Storage Tanks for Liquids:**

**A14.3.2.1 General:** Ground-supported, flat bottom tanks storing liquids shall be designed to meet the force requirements of the approved design standard given in Table A14.1.9, or the force and *displacement* provisions of Sec 3.1.3 and the provisions of this section. In addition, tanks or vessels storing liquids in *Seismic Use Group III*, or with a diameter greater than 20 feet shall be designed to consider the effects of sloshing and hydrodynamic pressures of the liquid in determining the equivalent lateral forces and lateral force distribution per the approved standards. See Ref. A14-1, A14-4, and A14-10.

**A14.3.2.1.1 Freeboard:** Sloshing of the liquid within the *container* shall be considered in determining the freeboard required above the top capacity liquid level. A minimum freeboard shall be provided per Table A14.3.2.1.1. The height of the sloshing wave can be estimated by:

$$s = 0.4DS_a \tag{A14.3.2.1.1-1}$$

where  $D$  = the tank diameter in feet,  $S_a$  = spectral acceleration, including site factor, as a multiplier of gravity corresponding to the sloshing period,  $T_{slosh}$ , and 0.5% damping.

$$T_{slosh} = 2 \sqrt{\frac{D}{3.68g \tanh\left(\frac{3.68H}{D}\right)}} \tag{A14.3.2.1.1-2}$$

where  $H$  = liquid height ( feet or meters) and  $g$ =acceleration due to gravity in consistent units.

For  $T_{slosh}$  less than 4.0 sec,  $S_a = \frac{1.5S_{DI}}{T_{slosh}}$

For  $T_{slosh}$  4.0 sec or greater,  $S_a = \frac{6S_{DI}}{(T_{slosh})^2}$

**TABLE A14.3.2.1.1 Minimum Required Freeboard**

Seismic Use Group		
I	II	III
$a$	$a$	$c_s$
$a$	$a$	$c_s$
$a$	$0.7_s^b$	$c_s$
$a$	$0.7_s^b$	$c_s$

- <sup>a</sup> A freeboard of  $0.7_s$  is recommended for economic considerations but not required.
- <sup>b</sup> A freeboard equal to  $0.7_s$  is required unless one of the following alternatives are provided:
  1. Secondary containment is provided to control the product spill.
  2. The roof and supporting *structure* are designed to contain the sloshing liquid.
- <sup>c</sup> Freeboard equal to the calculated wave height,  $s$ , is required unless one of the following alternatives are provided:
  1. Secondary containment is provided to control the product spill.
  2. The roof and supporting *structure* are designed to contain the sloshing liquid.

**A14.3.2.1.2 Equipment and Attached Piping:** Equipment, piping, and walkways or other appurtenances attached to the *structure* shall be designed to accommodate the *displacements* imposed by *seismic forces*. (For piping *attachments*, see Section A14.3.1.2).



When the effects of sloshing must be considered per Sec A14.3.2.1; the *attachments* of internal equipment and accessories which are attached to the primary liquid or pressure retaining shell or bottom, or provide structural support for major *components* (e.g., a column supporting the roof rafters) shall be designed for the lateral loads due to the sloshing liquid in addition to the inertial forces. See Ref. A14-40.

**A14.3.2.1.4 Sliding resistance:** The transfer of the total lateral shear force between the tank or vessel and the subgrade shall be considered:

- a. For unanchored flat bottom steel tanks, the overall horizontal seismic shear force shall be resisted by friction between the tank bottom and the foundation or subgrade. Unanchored storage tanks must be proportioned such that sliding at the *base* will not occur when the tank is full of stored product. The maximum calculated seismic shear,  $V$ , must not exceed:

$$V_s \leq V \tan 30^\circ \quad (\text{A14.3.2.1.4-1})$$

$V$  shall be determined using  $W_{EFF}$  which is defined as the effective weight of the tank, roof and contents after reduction for coincident vertical earthquake. Lower values of the friction factor should be used if the design of bottom to supporting foundation does not justify the friction value above (e.g., leak detection membrane beneath the bottom with a lower friction factor, smooth bottoms, etc).

- b. No additional lateral anchorage is required for anchored steel tanks designed in accordance with the approved standard.

Local transfer of the shear from the *wall* of the tank into the *base* shall be considered. For cylindrical tanks and vessels, the peak local tangential shear shall be:

$$V_{\max} = \frac{2V}{D} \quad (\text{A14.3.2.1.4-1})$$

- a. Tangential shear in flat bottom steel tanks is transferred through the welded connection into the steel bottom. This transfer mechanism is considered satisfactory for steel tanks designed in accordance with the approved standard and  $S_{as} < 1.0g$ .
- b. For concrete tanks with a sliding *base* where the lateral shear is resisted by friction between the tank *wall* and the *base*, the friction coefficient shall not exceed  $\tan 30^\circ$ .
- c. Fixed-*base* or hinged-*base* concrete tanks transfer the horizontal seismic *base shear* by membrane (tangential) shear, and partially by radial shear into the foundation. For anchored flexible-*base* concrete tanks, the majority of the *base shear* is resisted by membrane (tangential) shear through the anchoring system with only insignificant vertical bending in the *wall*. The connection between the *wall* and floor shall be designed to resist the peak tangential shear,  $V_{\max}$ .

The lateral shear transfer behavior for special tank configurations (e.g., shovel bottoms, highly crowned tank bottoms, tanks on grillage) can be unique and are beyond the scope of these provisions.

**A14.3.2.1.6 Pressure Stability:** For steel tanks, the internal pressure from the stored product can stiffen thin cylindrical shell structural *elements* subjected to membrane compression forces. This

stiffening effect can be considered in resisting seismically induced compressive forces if permitted by the approved standard.

**A14.3.2.1.7 Shell Support:** Steel tanks resting on concrete ring *walls* or slabs shall have a uniformly supported annulus under the shell. Uniform support can be achieved by one of the following methods:

- a. Shimming and grouting the annulus,
- b. Using fiberboard,
- c. Using butt-welded bottom or annular plates resting directly on the foundation,
- d. Using closely spaced shims ( without structural grout).

Local buckling of the steel shell for the peak compressive force due to operating loads and seismic overturning shall be considered.

**A14.3.2.2 Water and Water Treatment Structures:**

**A14.3.2.2.1 Welded Steel:** Welded steel water storage *structures* shall be designed in accordance with the seismic requirements of Ref. 14-4 except that the design input forces shall be modified as follows:

Given  $T_e$ , the natural period of tank shell plus confined liquid (including the effects of soil-*structure* interaction if applicable):

- a. If  $T_e \leq \frac{S_{DI}}{S_{DS}}$ , then substitute  $\frac{S_{DS}I}{2.5(1.68R)}$  for  $\frac{ZI}{R_w}$  into Eq. (14-4) and (14-8) in Ref. A14-4.

with the site amplification factor,  $S$ , in these formula set equal to 1.0.

- b. If  $T_e > \frac{S_{DI}}{S_{DS}}$ , then substitute  $\frac{S_{DS}I}{2.5(1.68R)}$  for  $\frac{ZI}{R_w}$  into Eq. (14-4) and (14-8) in Ref. A14-4.

with the site amplification factor,  $S$ , in these equations set equal to  $2.5T_e$ .

**A14.3.2.2.2 Bolted Steel:** Bolted steel water storage *structures* shall be designed in accordance with the seismic requirements of Ref. 14-29 except that the design input forces shall be modified as follows:

Given  $T_e$ , the natural period of tank shell plus confined liquid (including the effects of soil-*structure* interaction if applicable):

- a. If  $T_e \leq \frac{S_{DI}}{S_{DS}}$ , then substitute  $\frac{S_{DS}I}{2.5(1.68R)}$  for  $\frac{ZI}{R_w}$  into Eq. (15) and (16) in Ref. A14-29. with

the site amplification factor,  $S$ , in these formulas set equal to 1.0.

- b. If  $T_e > \frac{S_{DI}}{S_{DS}}$ , then substitute  $\frac{S_{DS}I}{2.5(1.68R)}$  for  $\frac{ZI}{R_w}$  into Eq. (14-4) and (14-8) in Ref. A14-4.

with the site amplification factor,  $S$ , in these equations set equal to  $2.5T_e$ .

**A14.3.2.2.3 Reinforced Concrete:** Reinforced concrete tanks shall be designed in accordance with the seismic requirements of Ref. A14-10 except that the design input forces shall be modified as follows:

Given  $T_i$ , the natural period of vibration of the tank shell (*wall*) plus the impulsive *component* of the stored liquid:

$$\text{For } T_i \leq T_o, \text{ substitute } \frac{S_{DS}I}{1.68R} \text{ for } \frac{ZIS}{R_{wi}} C_i$$

$$\text{For } T_i > T_o \text{ substitute } \frac{S_{DI}I}{T_i(1.68R)} \text{ for } \frac{ZIS}{R_{wi}} C_i$$

Given  $T_{slosh}$ , the natural period of oscillation of the convective (sloshing) *component* of the stored

liquid; for all values of  $T_{slosh}$  substitute  $\frac{6S_{DI}}{(T_{slosh})^2}$  for  $\frac{ZIS}{R_{wc}} C_c$

**A14.3.2.2.4 Prestressed Concrete:** Circular prestressed concrete tanks shall be designed in accordance with the seismic requirements of Ref. A14-30 or A14-16 as applicable except that the design input forces shall be modified as follows:

Given  $T_i$ , the natural period of vibration of the tank shell (*wall*) plus the impulsive *component* of the stored liquid:

$$\text{For } T_i \leq T_o, \text{ substitute } \frac{S_{DS}I}{1.68R} \text{ for } \frac{ZIS}{R_I} C_I$$

$$\text{For } T_i > T_o, \text{ substitute } \frac{S_{DI}I}{T_i(1.4R)} \text{ for } \frac{ZIS}{R_I} C_I$$

Given  $T_{slosh}$ , the natural period of oscillation of the convective (sloshing) *component* of the stored

liquid; for all values of  $T_{slosh}$  substitute  $\frac{6S_{DI}}{(T_{slosh})^2}$  for  $\frac{ZIS}{R_C} C_C$

**A14.3.2.3 Petrochemical and Industrial Liquids:**

**A14.3.2.3.1 Welded Steel:** Welded steel petrochemical storage *structures* shall be designed in accordance with the seismic requirements of Ref. A14-1 and Ref. A14-28 except that the design input forces shall be modified as follows:

Given  $T_e$  = the natural period of tank shell plus confined liquid (including the effects of soil-*structure* interaction if applicable),

- a. If  $T_e \leq \frac{S_{DI}}{S_{DS}}$ , then substitute  $\frac{S_{DS}I}{2.5}$  for ZI into the overturning moment equation in Appendix E of

Ref. A14-1 and Appendix L in Ref. 14-28. with the site amplification factor,  $S$ , set equal to 1.0 when determining the lateral force coefficients.

- b. If  $T_e > \frac{S_{DI}}{S_{DS}}$ , then substitute  $\frac{S_{DI}I}{2.5T_e}$  for ZI into the overturning moment equation in Appendix E

of Ref. A14-1 and Appendix L in Ref. A14-28. with the site amplification factor,  $S$ , set equal to  $2.5T_e$  when determining the lateral force coefficients.

**A14.3.2.3.2 Reinforced Concrete:** Reinforced concrete tanks for the storage of petrochemical and industrial liquids shall be designed in accordance with the force requirements of Sec. 14.4.3.2.2.3.

**A14.3.2.3.3 Prestressed Concrete:** Prestressed concrete tanks for the storage of petrochemical and industrial liquids shall be designed in accordance with the force requirements of Sec. A14.3.2.2.4.

**A14.3.3 Ground-Supported Storage Tanks for Granular Materials:**

**A14.3.3.1 General:** The intergranular behavior of the material shall be considered in determining effective mass and load paths, including the following behaviors:

- Increased lateral pressure (and the resulting hoop stress) due to loss of the intergranular friction of the material during the seismic shaking.
- Higher hoop stresses generated from temperature changes in the shell material after the material has been compacted.
- Intergranular friction which can transfer seismic shear directly to the foundation.
- The effects of sloshing may be ignored.

**A14.3.3.2 Lateral Force Determination:** The lateral forces for tanks and vessels storing granular materials at grade shall be determined by the requirements and accelerations for short period structures (i.e.,  $S_{as}$ ).

**A14.3.3.3 Force Distribution to Shell and Foundation:**

**A14.3.3.3.1 Increased Lateral Pressure:** The increase in lateral pressure on the tank *wall* shall be added to the static design lateral pressure but shall not be used in the determination of pressure stability effects on the axial buckling strength of the tank shell.

**A14.3.3.3.2 Effective mass:** A portion of a stored granular mass will act with the shell (the “effective mass”). The effective mass is related to the height-to-diameter ( $H/D$ ) ratio of the tank and the intensity of the seismic event. The effective mass shall be used to determine the shear and overturning loads resisted by the tank.:

**A14.3.3.3.3 Effective density:** The “effective density” factor (that part of the total stored mass of product which is accelerated by the seismic event) shall be determined from Ref. A14-43.

**A14.3.3.3.4 Lateral sliding:** For granular storage tanks which have a steel bottom and are supported such that friction at the bottom to foundation interface can resist lateral shear loads, no additional anchorage to prevent sliding is required. For tanks without steel bottoms (i.e., the material rests directly on the foundation), shear anchorage shall be provided to prevent sliding.

**A14.3.3.3.5 Combined anchorage systems:** If separate anchorage systems are used to prevent overturning and sliding, the relative stiffness of the systems shall be considered in determining the load distribution.

**A14.3.3.4 Welded Steel Structures:** Welded steel granular storage *structures* shall be designed for Chapter 2 of these *Provisions*. Allowable *component* stresses and materials shall be per Ref. A14-4, except the allowable circumferential membrane stresses and material requirements in Ref. A14-1 shall apply.

**A14.3.3.5 Bolted Steel Structures:** Bolted steel granular storage *structures* shall be designed in compliance with Sec A14.2. Allowable *component* stresses and materials shall be per Ref. A14-29.

**A14.3.3.6 Reinforced Concrete Structures:** Reinforced concrete *structures* for the storage of granular materials shall be designed in accordance with the force requirements of Sec. A14.3.2.2.3.

**A14.3.3.7 Prestressed Concrete Structures:** Prestressed concrete *structures* for the storage of granular materials shall be designed in accordance with the force provisions of Sec. A14.3.2.2.4.

#### **A14.3.4 Elevated Tanks for Liquids and Granular Materials:**

**A14.3.4.1 General:** This section pertains to tanks elevated above *grade* where the supporting tower is an integral part of the structure, or where the primary function of the tower is to support the tank or vessel. Tanks and vessels that are supported within buildings, or are incidental to the primary function of the tower are considered mechanical equipment which is addressed in Chapter 3 of these *Provisions*.

Elevated tanks shall be designed for the force and *displacement* requirements of the applicable approved standard, or Sec A14.2.

**A14.3.4.1.1 Effective mass:** The design of the supporting tower or pedestal, anchorage, and foundation for seismic overturning shall assume the material stored is a rigid mass acting at the volumetric center of gravity. The effects of fluid-*structure* interaction shall be evaluated in determining the forces, effective period and centroids of the system if the sloshing period,  $T_{slosh}$  is greater than  $3T_e$ , where  $T_e$  = natural period of the tank with confined liquid (rigid mass) and supporting *structure*. Soil *structure* interaction shall be evaluated in determining  $T_e$  providing the provisions of Sec 2.5 are met.

**A14.3.4.1.2 P-Delta effects:** The lateral drift of the elevated tank shall be considered as follows:

- a. The design drift, the elastic lateral *displacement* of the stored mass center of gravity shall be increased by the factor,  $C_d$  for evaluating the additional load in the support *structure*.
- b. The *base* of the tank shall be assumed to be fixed rotationally and laterally
- c. Deflections due to bending, axial tension or compression shall be considered. For pedestal tanks with a height to diameter ratio less than 5, shear *deformations* of the pedestal shall be considered.
- d. The *dead load* effects of roof mounted equipment or platforms shall be included in determining the additional bending moment.
- e. If constructed within the plumbness tolerances specified by the approved standard, initial tilt need not be considered in addition to the  $P$ -delta load.

**A14.3.4.1.3 Transfer of Lateral Forces into Support Tower:** For post supported tanks and vessels which are cross braced:

- a. The bracing shall be installed in such a manner as to provide uniform resistance to the lateral load (e.g. pre-tensioning, tuning to attain equal sag).
- b. The additional load in the brace due to the eccentricity between the post to tank attachment and the line of action of the bracing shall be included.
- c. Eccentricity of compression strut line of action (*elements* that resist the tensile pull from the bracing rods in the lateral force resisting systems) with their attachment points shall be considered.
- d. The connection of the post or leg with the foundation shall be designed to resist both the vertical and lateral resultant from the yield load in the bracing assuming the direction of the lateral load is oriented such as to produce the maximum lateral shear at the post to foundation interface. Where multiple rods are connected to the same location, the anchorage shall be designed to resist the concurrent tensile loads in the braces.

**A14.3.4.1.5 Welded Steel:** Welded steel elevated water storage *structures* shall be designed in accordance with the seismic requirements of Ref. A14-4 except that the design input forces shall be modified as follows:

Given  $T_e$ , the natural period of tank shell plus confined liquid (including the effects of soil-*structure* interaction if applicable):

- a. If  $T_e \leq \frac{S_{DI}}{S_{DS}}$ , then substitute  $\frac{S_{DS}I}{2.5(1.68R)}$  for  $\frac{ZIC}{R_w}$  into formulas. (14-1) and (14-3) in Ref. 14-

4.

- b. If  $T_e > \frac{S_{DI}}{S_{DS}}$ , then substitute  $\frac{S_{DI}I}{T_e(1.68R)}$  for  $\frac{ZIC}{R_w}$  into formulas (14-1) and (14-3) in Ref. A14-

4. The maximum value of  $T_e$  shall be 5 sec.

**A14.3.5 Boiler and Pressure Vessels:**

**A14.3.5.1 General:** *Attachments* to the pressure boundary, supports, and lateral force resisting anchorage systems for boilers and pressure vessels shall be designed to meet the force and *displacement* requirements of Sec 3.1.3 and 3.1.4 and the additional requirements of this section. Boilers and pressure vessels categorized as *Seismic Use Group II* or *III* shall themselves be designed to meet the force and *displacement* requirements of Sec 3.1.3 and 3.1.4.

**A14.3.5.2 ASME Boilers and Pressure Vessels:** Boilers or pressure vessels designed and constructed in accordance with Ref. A14-4 shall be deemed to meet the requirements of this section providing the *displacement* requirements of Sec 3.1.3 and 3.1.4 are used, with appropriate scaling of the force and *displacement* requirements to the working stress design basis.

**A14.3.5.3 Attachments of Internal Equipment and Refractory:** *Attachments* to the pressure boundary for internal and external ancillary *components* (refractory, cyclones, trays, etc) shall be designed to resist the *seismic forces* in these provisions to safeguard against rupture of the pressure boundary. Alternatively, the *element* attached could be designed to fail prior to damaging the pressure boundary providing the consequences of the failure does not place the pressure boundary in jeopardy. For boilers or vessels containing liquids, the effect of sloshing on the internal equipment shall be considered if the equipment is related to the integrity of the pressure boundary.

**A14.3.5.4 Coupling of Vessel and Support Structure:** Where the mass of the operating vessel or vessels supported is greater than 25 percent of the total mass of the combined *structure*, the coupling of the masses shall be considered. Coupling with adjacent, connected *structures* such as multiple towers shall be considered if the *structures* are interconnected with *elements* that will transfer loads from one *structure* to the other.

**A14.3.5.5 Effective mass:** Fluid-*structure* interaction (sloshing) shall be considered in determining the effective mass of the stored material providing sufficient liquid surface exists for sloshing to occur and the  $T_{slosh}$  is greater than  $3T_e$ . Changes to or variations in material density with pressure and temperature shall be considered.

**A14.3.5.6 Other Boilers and Pressure Vessels:** Boilers and pressure vessels designated *Seismic Use Group III* but are not designed and constructed in accordance with the requirements of Ref. A14-2 shall meet the following requirements:

The design strength for seismic loads in combination with other service loads and appropriate environmental effects shall not exceed the maximum material strength shown in Table A14.3.5.6.

**TABLE A14.3.5.6 Maximum Material Strength**

	Minimum ratio $F_u/F_y$	Max Material Strength Vessel Material	Max Material Strength Threaded Material <sup>a</sup>
Ductile (e.g., steel, aluminum, copper)	1.33 <sup>b</sup>	90%	70%
Semi-ductile	1.2 <sup>c</sup>	70%	50%
Nonductile (e.g., cast iron, ceramics, fiberglass)	NA	25%	20%

	Minimum ratio $F_u/F_y$	Max Material Strength Vessel Material	Max Material Strength Threaded Material <sup>a</sup>
--	----------------------------	--	---

<sup>a</sup> Threaded connection to vessel or support system.

<sup>b</sup> Minimum 20% elongation per the ASTM material specification.

<sup>c</sup> Minimum 15% elongation per the ASTM material specification.

Consideration shall be made to mitigate seismic impact loads for boiler or vessel *components* constructed of nonductile materials or vessels operated in such a way that material ductility is reduced (e.g., low temperature applications).

**A14.3.5.7 Supports and Attachments for Boilers and Pressure Vessels:** *Attachments* to the pressure boundary and support for boilers and pressure vessels shall meet the following requirements:

- a. *Attachments* and supports transferring seismic loads shall be constructed of ductile materials suitable for the intended application and environmental conditions.
- b. *Attachments* or anchorages embedded in concrete shall be ductile and detailed to be suitable for cyclic loads.
- c. Seismic supports and *attachments* to support *structures* shall be designed and constructed so that the support or attachment is maintained throughout the range of reversing lateral loads and *displacements*.
- d. Vessel *attachments* shall consider the potential effect on the vessel and the support for uneven vertical reactions based on variations in relative stiffness of the support members, dissimilar details, nonuniform shimming or irregular supports. Uneven distribution of lateral forces shall consider the relative distribution of the resisting *elements*, the behavior of the connection details, and vessel shear distribution.

The requirements of Sec A14.3.4.1.3 shall also be applicable to this section.

**A14.3.6 Liquid and Gas Spheres:**

**A14.3.6.1 General:** *Attachments* to the pressure or liquid boundary, supports, and lateral force resisting anchorage systems for liquid and gas spheres shall be designed to meet the force and *displacement* requirements of Sec 3.1.3 and 3.1.4 and the additional requirements of this section. Spheres categorized as *Seismic Use Group II* or *III* shall themselves be designed to meet the force and *displacement* requirements of Sec 3.1.3 and 3.1.4.

**A14.3.6.2 ASME Spheres:** Spheres designed and constructed in accordance with Division VIII of Ref. 14-2 shall be deemed to meet the requirements of this section providing the *displacement* requirements of Sec 3.1.3 and 3.1.4 are used, with appropriate scaling of the force and *displacement* requirements to the working stress design basis.

**A14.3.6.3 Attachments of Internal Equipment and Refractory:** *Attachments* to the pressure or liquid boundary for internal and external ancillary *components* (refractory, cyclones, trays, etc.) shall be designed to resist the *seismic forces* in these provisions to safeguard against rupture of the pressure boundary. Alternatively, the *element* attached to the sphere could be designed to fail prior to damaging the pressure or liquid boundary providing the consequences of the failure does not place the pressure



boundary in jeopardy. For spheres containing liquids, the effect of sloshing on the internal equipment shall be considered if the equipment is related to the integrity of the pressure boundary.

**A14.3.6.4 Effective mass:** Fluid-*structure* interaction (sloshing) shall be considered in determining the effective mass of the stored material providing sufficient liquid surface exists for sloshing to occur and the  $T_{slosh}$  is greater than  $3T_e$ . Changes to or variations in material density shall be considered.

**A14.3.6.5 Post and Rod Supported:** For post supported spheres that are cross braced:

- a. The requirements of Sec A14.3.4.1.3 shall also be applicable to this section.
- b. The stiffening effect of (reduction in lateral drift) from pre-tensioning of the bracing shall be considered in determining the natural period.
- c. The slenderness and local buckling of the posts shall be considered.
- d. Local buckling of the sphere shell at the post attachment shall be considered.
- e. For spheres storing liquids, bracing connections shall be designed and constructed to develop the minimum published tensile yield strength of the brace. For spheres storing gas vapors only, bracing connection shall be designed for  $\phi$  times the maximum design load in the brace. Lateral bracing connections directly attached to the pressure or liquid boundary are prohibited.

**A14.3.6.6 Skirt Supported:** For skirt supported spheres, the following requirements shall apply:

- a. The local buckling of the skirt under compressive membrane forces due to axial load and bending moments shall be considered.
- b. Penetration of the skirt support (manholes, piping, etc) shall be designed and constructed to maintain the strength of the skirt without penetrations.

### **A14.3.7 Refrigerated Gas Liquid Storage Tanks and Vessels:**

**A14.3.7.1 General:** The seismic design of the tanks and facilities for the storage of liquefied hydrocarbons and refrigerated liquids is beyond the scope of this section. The design of such tanks is addressed in part by various approved standards as listed in Table A14.1.9.

**Exception:** Low pressure, welded steel storage tanks for liquefied hydrocarbon gas (e.g., LPG, Butane, etc) and refrigerated liquids (e.g., ammonia) could be designed in accordance with the requirements of Sec. 14.4.3.2.3.1 and Ref. 14-28.

### **A14.3.8 Horizontal, Saddle Supported Vessels for Liquid or Vapor Storage:**

**A14.3.8.1 General:** Horizontal vessels supported on saddles (sometimes referred to as blimps) shall be designed to meet the force and *displacement* requirements of Sec 3.1.3 and 3.1.4.

**A14.3.8.2 Effective mass:** Changes to or variations in material density shall be considered. The design of the supports, saddles, anchorage, and foundation for seismic overturning shall assume the material stored is a rigid mass acting at the volumetric center of gravity.

**A14.3.8.3 Vessel Design:** Unless a more rigorous analysis is performed,

- a. Horizontal vessels with a length to diameter ratio of 6 or more could be assumed to be a simply supported beam spanning between the saddles for determining the natural period of vibration and global bending moment.
- b. Horizontal vessels with a length to diameter ratio of less than 6, the effects of “deep beam shear” shall be considered when determining the period and stress distribution.
- c. Local bending and buckling of the vessel shell at the saddle supports due to seismic load shall be considered. Pressure stability effects shall not be considered to increase the stability of the vessel shell.
- d. If the vessel is a combination of liquid and gas storage, the vessel and supports shall be designed with and without gas pressure acting (assume piping has ruptured and pressure does not exist).

**A14.3.9 Impoundment Dikes and Walls:**

**A14.3.9.1 General:** Secondary containment systems shall meet the requirements of the cited references in Table 14.1.9 and the authority having jurisdiction.

Secondary containment systems shall be designed to withstand the effects of a *maximum considered earthquake* event when empty and a *maximum considered earthquake* when full including all hydrodynamic forces.

**A14.3.9.2 Freeboard:** Sloshing of the liquid within the secondary containment area shall be considered in determining the height of the impound. A minimum freeboard,  $s$ , (Sec 14.4.3) shall be provided where:

$$s = 0.40DS_a$$

where  $S_a$  determined per 14.4.3.2.1.1. For circular impoundment dikes,  $D$  shall be the diameter of the impoundment. For rectangular impoundment dikes,  $D$  shall be the longer longitudinal plan dimension.

**A14.4 ELECTRICAL TRANSMISSION, SUBSTATION, AND DISTRIBUTION STRUCTURES:**

**A14.4.1 General:** This section applies to electrical transmission, substation, and distribution structures.

**A14.4.2 Design Basis:** Electrical transmission, substation wire support and distribution structures shall be designed to resist a minimum seismic lateral load determined from the following formula:

$$V = \frac{C_s}{\left(\frac{R}{I}\right)} W$$

where:

$V$  = seismic base shear;

- $I$  = importance factor,  $I = 1.0$ ;
- $W$  = total *dead load* (does not include the supported wire, or ice and snow loads applied to the tower);
- $R$  = response modification factor, Table 14.2.1.1;
- $C_s$  = *seismic response coefficient* --  $S_{DS}$  but not greater than  $S_{DI}/T$  where  $S_{DS}$  and  $S_{DI}$  are as defined in Sec.1.4.2.2: and
- $T$  = The fundamental period of the tower.

A simplified static analysis and applying the seismic *base shear* (times a load factor of 1.0) at the center of mass of the *structure* can be used to determine if seismic load controls the design. The lateral force shall be evaluated in both the longitudinal and transverse directions to the support wire. When it is determined that seismic loads are significant (control the design of main load carrying members) a more detailed lateral force distribution shall be performed per Sec. 14.2.1 (with  $k=1$ ) of these *Provisions* and/or a modal analysis as specified by Sec. A.1.5 of Ref. 14-5.

Seismic lateral loads and design criteria for substation *equipment support structures* shall be in accordance with the requirements of Ref. 14-5.

The design, manufacture, and inspection shall be in accordance with the quality control and quality assurance requirements of the industry design standards and recommended practices specified in Sec. 14.1.9.

#### **A14.5 TELECOMMUNICATION TOWERS:**

**A14.5.1 General:** This section applies to telecommunication towers.

**A14.5.2 Design Basis:** Self-supporting telecommunication towers shall be designed to resist a minimum seismic lateral force obtained from the following formula:

$$V = \frac{C_s}{(R/I)} W \quad (\text{A14.5.2})$$

where:

- $V$  = seismic *base shear*;
- $I$  = importance factor, Table 14.2.1.2;
- $W$  = total *dead load* (including all *attachments*);
- $R$  = response modification factor, Table 14.2.1.1;
- $C_s$  = *seismic response coefficient*:  $S_{DS}$  but not greater than  $S_{DI}/T$  where  $S_{DI}$  and  $S_{DS}$  are as defined in Sec. 4.2.2 and  $T$  is the fundamental period of the tower

A simplified static analysis applying the lateral load (times a load factor of 1.0) at the center of mass of the tower can be used to determine if seismic load controls the design of self-supporting towers. When it is determined that seismic loads are significant (control the design of main load carrying members) a

more detailed lateral force distribution (with  $k = 1$ ) and analysis shall be performed per Sec. 14.2.1 of these *Provisions*.

The lateral force applied to a telecommunication tower supported on a structure should account for the *base* motion input amplification as a result of the building earthquake response (see Sec. 14.1.2 of these *Provisions*). Guyed towers require a more detailed computer analysis including nonlinear analysis and guy-tower interaction effects. An industry accepted modal analysis procedure should be used for guyed towers.

The design, manufacture, and inspection shall be in accordance with the quality control and quality assurance requirements of the industry design standards and recommended practices specified in Sec. 14.1.9.

## Appendix A

# DIFFERENCES BETWEEN THE 1994 AND 1997 EDITIONS OF THE *NEHRP RECOMMENDED PROVISIONS*

### EDITORIAL AND ORGANIZATIONAL CHANGES

Several editorial changes have been made for the 1997 Edition of the *Provisions*. These include: a change in the title to add “Other Structures”; change of the term “Seismic Performance Category” to “Seismic Design Category”; change of the term “Seismic Hazard Exposure Group” to “Seismic Use Group”; and change of the term “building” to “structure” as appropriate. In addition, the structure of the *Provisions* has been revised as follows:

- 1994 Sec. 1.4, Seismic Performance, has been moved to become part of 1997 Chapter 5, Ground Motion.
- 1994 Sec. 1.6, Quality Assurance, has become 1997 Chapter 3.
- 1994 Glossary and Notations sections have become 1997 Chapter 2.
- 1994 Sec. 2.1 through 2.5 have become 1997 Chapter 5, Structural Design Criteria.
- 1994 Sec. 2.6, Provisions for Seismically Isolated Structures, has become 1997 Chapter 13 and the 1994 Appendix to Chapter 2, Passive Energy Dissipation Systems, has become 1997 Appendix to Chapter 13.
- 1994 Sec. 2.7, Provisions for Nonbuilding Structures, has become 1997 Chapter 14.
- 1994 Chapters 3 through 9 have become 1997 Chapters 6 through 12.

To facilitate use of the 1997 Edition by those familiar with the 1994 Edition section numbers, this appendix concludes with a comparison of the contents of the two editions.

### 1997 CHAPTER 1, GENERAL PROVISIONS

In addition to the general editorial changes outlined above, this chapter has been reorganized. In addition, the seismic performance requirements (1994 Sec. 1.4) have been moved to a new chapter (1997 Chapter 5, Ground Motion) as have the quality assurance requirements (1994 Sec. 1.6/1997 Chapter 3).

#### 1997 and 1994 Sec. 1.1, Purpose

The language in this section has been modified for clarification and to emphasize that damage to an essential facility from a design earthquake is not expected to be severe enough to preclude the continued occupancy and function of the facility.

#### 1994 Sec. 1.2, Purpose and 1994 Sec. 1.3, Application of the Provisions/1997 Sec. 1.2, Scope and Application, and 1994 Alternative Materials and Methods of Construction

The language in this section has been modified to clarify the requirements concerning additions and alterations. In addition, Exception 2 has been changed to clarify that the sole trigger is whether a dwelling complies with the conventional light frame construction provisions and the other exceptions have been modified to reflect the new maps and design procedure. The listing of structures not covered by the *Provisions* has been deleted; instead this information is conveyed in Chapter 14, Nonbuilding Structures.

The main 1994 section on application of the *Provisions* has been deleted and the 1994 subsections of Sec. 1.3 are now subsections of 1997 Sec. 1.2. Those covering new structures and additions have been revised to clarify the requirements and a new subsection on alterations has been added. In addition, 1994 Sec. 1.5, Alternative Materials and Methods of Construction has been moved here as another subsection of 1997 Sec. 1.2 and the title has been changed to Alternate Materials and Alternate Means and Methods of Construction.

### **1994 Sec. 1.4.3, Seismic Hazard Exposure Groups/1997 Sec. 1.3, Seismic Use Groups**

In addition to the basic editorial change in terminology from “Seismic Hazard Exposure Group” to “Seismic Use Group, the list of potential Group III structures has been modified to be more specific and aviation control towers, air traffic control centers, and water treatment facilities required to maintain water pressure for fire suppression have been added. The list of potential Group II facilities has been modified to lower the capacity of day care centers to 150, to delete the item for colleges or adult education schools, and to add water treatment facilities required for primary treatment and disinfection for potable water and waste water treatment facilities required for primary treatment. The subsection on multiple use section has been modified to take into account situations where one building with multiple uses has been designed with seismically independent portions. Finally, the subsection on Group III function has been deleted because it erroneously implied that the *Provisions* do not properly address component and system function.

### **1997 Sec. 1.4, Occupancy Important Factor**

A section on the new Occupancy Importance Factor has been added. As noted above, the 1994 Sec. 1.4, Seismic Performance, has become part of 1997 Chapter 4, Ground Motion

### **1994 Sec. 1.5, Alternative Materials and Methods of Construction/1997 Sec. 1.2.6, Alternate Materials and Alternate Means and Methods of Construction**

As noted above, this section has been moved and retitled.

### **1994 Sec. 1.6, Quality Assurance**

As noted above, this section has become 1997 Chapter 3.

### **1994 Appendix to Chapter 1**

The Appendix to Chapter 1, Development of Design Value Maps, has been deleted and the new 1997 maps and their development are covered in the *Commentary* to 1997 Chapter 4, Ground Motion.

## **1997 CHAPTER 2, GLOSSARY AND NOTATIONS**

The 1994 Glossary and Notations sections appeared at the conclusion of the *Provisions* volume but now appear as Chapter 2.

### **1997 Sec. 2.1, Glossary**

A number of definitions have been added or deleted as a result of the changes in the design procedure and maps used for the 1997 *Provisions*. The definition of other terms have been clarified and a number of terms have been defined for the first time to further clarify various *Provisions* requirements and provide for the enforceability of requirements based on the *Provisions*.

Specifically, definitions have been added for the following terms: active fault, addition, adjusted resistance, alteration, basement, boundary elements, braced wall line, braced wall panel, cantilevered column system, construction documents, deformability (high deformability element, low deformability element, limited deformability element), deformation (limited deformation and ultimate deformation), design earthquake ground motion, blocked diaphragm, diaphragm boundary, diaphragm chord, drag strut, element (ductile element, limited ductile element, nonductile element, essential facility, factored resistance, grade plain, maximum considered earthquake, occupancy importance factor, owner, partition, reference resistance, registered design professional, seismic design category, seismic use group, shallow anchor, site class, story, story above grade, structure, structural observations, structural-use panel, subdiaphragm, tie-down, time effect factor, torsional force distribution, light-framed wood shear wall, and nonstructural wall.

Definitions for the following terms have been deleted: effective peak acceleration, effective peak velocity related acceleration, collector elements, composite (composite beam, composite brace, composite column, composite column, composite slab, composite shear wall, encased composite beam, fully composite beam, partially composite beam, partially restrained composite connection), design documents, encased composite beam, encased composite column, encased shape, filled composite column, maximum capable earthquake, restraining bars, seismic coefficients, seismic hazard exposure group, and Seismic Performance Category.

Definitions for the following terms have been modified: building, design earthquake, designated seismic system, diaphragm, displacement restraint system, isolation system, nonbuilding structure, quality assurance plan, cripple wall, and shear wall.

### **1997 Sec. 2.2, Notations**

Changes to the definitions for the notations have been made to reflect changes to the *Provisions*.

## **1997 CHAPTER 3, QUALITY ASSURANCE**

As noted above, the quality assurance provisions that previously appeared as part of Chapter 1 now appear in a dedicated chapter. With respect to specific changes from the 1994 requirements, the exemption for when a quality assurance plan is not required has been more clearly defined, and the details of the quality assurance plan have been systematically enumerated. Special inspection requirements have been added for cold-formed steel framing and seismic isolation systems. In addition, requirements concerning structural observations as well as a definition for structural observations have been included. The requirements for continuous special inspections during the placement of concrete in piles, for periodic inspections for components within the seismic-force-resisting system have been

clarified, and for which portions of construction are to be tested have been clarified. The testing requirements for structural steel also have been modified to reflect up-to-date reference standards and lessons learned from the Northridge earthquake.

## **1997 CHAPTER 4, GROUND MOTION**

### **1994 Sec. 1.4, Seismic Performance/1997 Sec. 4.1, Procedures for Determining Maximum Considered Earthquake and Design Earthquake Ground Motion Accelerations and Response Spectra**

In order to adopt the recommendations of the Seismic Design Procedures Group (SDPG) Ground Motion Task Group into the 1997 *Provisions* as a dedicated chapter, the title of 1994 Sec. 1.4 has been changed in recognition of the fact that the new design maps are maps of contours of ground motions characterized by spectral response accelerations.

The 1994 subsection dealing with the seismic ground acceleration maps has been replaced by a new subsection covering maximum considered earthquake ground motions and introducing the new maps (1997 Sec. 4.1.1).

In recognition of the fact that design spectral response accelerations can be obtained either from the maps or on the basis of a site-specific geotechnical study, the 1994 subsection dealing with seismic coefficients (1994 Sec. 1.4.2) has been modified to provide a general procedure for determining maximum considered earthquake and design spectral response accelerations (1997 Sec. 4.1.2) based on the new maps and a site-specific procedure for determining ground motion accelerations (1997 Sec. 4.1.3) based on site-specific study. Further, a methodology for construction of a general design response spectrum based on the mapped spectral response accelerations is provided.

Note that with the exception of a change in terminology from “Soil Profile Types” in the 1994 edition to “Site Classes” in the 1997 edition, the site classification requirements remain essentially the same.

### **1994 Sec. 1.4.4, Seismic Performance Category/1997 Sec. 4.2, Seismic Design Category**

This section has been modified to make the Seismic Design Categories compatible with the new ground motion representations recommended by the SDPG.

### **1994 Sec. 1.4.5, Site Limitation for Seismic Performance Category E/1997n Sec. 4.2.2, Site Limitation for Seismic Design Categories E and F**

The basis for categorizing structures into Seismic Design Category E has been changed and a new Seismic Design Category F has been added. In 1994, Category E consisted of Group III structures in regions anticipated to experience strong ground motion ( $A_v > 0.2$ ). In 1997, Category E consists of Seismic Use Group I or II structures located within a few kilometers of major active faults as indicated by the maximum considered earthquake spectral response maps. Category F includes Seismic Use Group III structures located within a few kilometers of major active faults. Most buildings assigned to Category E in the 1994 *Provisions* are now assigned to Category D.

## **1997 CHAPTER 5, STRUCTURAL DESIGN CRITERIA**

---



### **1994 Sec. 2.1/1997 Sec. 5.1, Reference Document**

This section has been modified to reference the 1995 edition of ASCE 7, *Minimum Design Loads for Buildings and Other Structures*.

### **1997 Sec. 5.2, Design Basis**

This new major heading has been added to permit better organization of the requirements that follow.

#### **1994 Sec. 2.1.1/1997 Sec. 5.2.1, General**

This subsection has been revised to focus on the important aspects of seismic resistive design while acknowledging the order in which these issues normally are addressed in the design process are clarified to emphasize the basic steps of the design process as follows: develop complete vertical- and lateral-force-resisting systems for the structure; ensure that the system has adequate strength, stiffness, and energy dissipation capacity to resist the design ground motions; the ground motions must be assumed to occur from any direction; adequacy of the structural system is demonstrated through evaluating the behavior of the structure, using a linear elastic model, with respect to the prescribed seismic forces and comparing the computed deflections and internal forces against acceptance criteria contained in the *Provisions*; alternative rational procedures may be utilized; regardless of the analysis procedure adopted, provide a continuous load path or paths; design the foundations to resist the expected movements and forces.

In addition, an error in the 1994 *Provisions* concerning deformation is corrected to indicate that the *Provisions* attempts to control the actual expected deformations of the building under the design ground motion (using the  $C_d$  factor) rather than evaluating the deformation under design seismic forces, which are reduced substantially by the  $R$  factor.

#### **1994 Sec. 2.2.2, Structural Framing Systems/1997 Sec. 5.2.2, Basic Seismic-Force-Resisting System**

This section has been significantly revised. The response modification coefficient,  $R$ , has been used since the inception of the *Provisions* to represent in an approximate manner the beneficial effects of the inelastic behavior of structural systems when responding to intense ground motion. Although a single coefficient,  $R$ , has historically been used for this purpose, it is known that a number of beneficial effects of inelastic behavior permit structures to resist much stronger ground motion than that which they have been designed to resist on an elastic basis. Some of the more important factors include material and system ductility, period shift, hysteretic damping, and structural overstrength. Although a full partitioning of the  $R$  factor has not been adopted for the 1997 *Provisions*, the importance of structural overstrength in the inelastic response and performance of structures is emphasized.

In the 1994 *Provisions*, overstrength was recognized for the design of a limited number of elements such as columns beneath discontinuous lateral-force-resisting elements, and certain “brittle” components and was approximated by the factor  $2/5R$ , independent of the structural system. In the 1997 *Provisions*, a separate tabulated  $\rho$  factor replaces the arbitrary  $2/5R$  value in order to allow somewhat greater (or lesser) values to be assigned to the structural overstrength of different systems, while emphasizing to the designer the importance of this inelastic behavioral parameter. Note that the  $\rho$  factors are intended to be approximate, upper bound estimates of the probable overstrength inherent in the typical lateral force resisting systems of common structures. For most systems, these values are comparable to the  $2/5R$  values used in the past so that the impact on most contemporary designs will

be limited. In addition, it is emphasized that the designer is encouraged to make a more accurate, and potentially lower, estimate of overstrength by performing mechanism analyses of the structure.

In addition, a number of changes have been made in 1994 Table 2.2.2/1997 Table 5.2.2 to reflect the above as well as the SDPG's recommendation that within any given system type (e.g., special moment resisting frames) to which a single response modification coefficient  $R$  is assigned, a consistent and uniform set of rules for detailing should be adopted, regardless of the Seismic Design Category the structure is assigned to. It was recognized that this might require adoption of some new system naming conventions (e.g., special reinforced walls, intermediate reinforced walls, ordinary reinforced walls, etc.) together with the assignment of new  $R$  values to these systems consistent with the margin against failure provided the detailing specified for this system. Further, a new column has been added to the table to identify where in the *Provisions* the user will find the detailing rules for each unique system.

The requirements for dual systems have been modified to prevent the inappropriate use of dual system designs with flexible diaphragm structures.

### **1994 Sec. 2.2.3, Building Configuration/1997 Sec. 5.2.3, Structure Configuration**

This section has been modified considerably to adopt the recommendations of the SDPG relative to control of irregularities in near-field regions and a new subsection has been added to define the concept of diaphragm flexibility. Two new irregularities -- extreme torsional irregularity and extreme soft story irregularity -- are introduced and structures assigned to Seismic Design Categories E (Group I and II structures near active sources) and F (Group III structures near active sources) not be permitted to have either of these irregularities or a weak story.

### **1997 Sec. 5.2.4, Redundancy**

This new section introduces a reliability factor,  $\rho$ , that has the effect of reducing the effective response modification factor,  $R$ , based on the extent of redundancy inherent in the design configuration of the building and its lateral-force-resisting system. The value of  $\rho$ , which varies between 1.0 and 1.5, is calculated based on the size of the building floor plate as well as the number and distribution of vertical elements of the lateral-force-resisting system. Thus, structures with adequately redundant systems will continue to be designed using the same force levels contained in the 1994 *Provisions*, but structures that are not redundant or that have highly torsional systems would have to be designed for larger seismic forces ranging up to 150 percent of those specified by the 1994 *Provisions*.

The  $\rho$  factor is applied in the load combination equations rather than in the base shear equation so that stiffness and drift control requirements are not directly affected. In addition, since redundancy is an important seismic resistant feature only for structures expected to experience severe inelastic demands, the proposed provision will not apply to structures in Seismic Design Categories A, B, or C.

### **1994 Sec. 2.2.4/1997 Sec. 5.2.5, Analysis Procedures**

This section has been revised significantly to reflect the recommendations of the Seismic Design Procedures Group and also to clarify the intent. The irregularities that trigger various types of analyses have been changed. Other major changes involve the placement of limits on design forces required for stiff regular buildings located within a few kilometers of major active faults so that design of these structures remains compatible with that specified by the 1994 *Provisions*.

The section also is reformatted somewhat to accommodate Seismic Design Categories E and F which directly include near-source requirements.

A new subsection on diaphragms (1997 Sec. 5.2.5.4) is added to recognize that the design forces for diaphragms are related to the height of their placement within the structure.

#### **1994 Sec. 2.2.5/1997 Sec. 2.2.6, Design, Detailing Requirements, and Structural Component Load Effects**

One major change in this section is the introduction in Sec. 5.2.6.1.1, Component Load Effects, of a minimum design seismic force equal to 1 percent of the weight of the structure at each level for Category A structures. This change reflects the SDPG recommendation that buildings in zones of very low seismicity (Seismic Design Category A) be designed for a minimum lateral force equal to 1 percent of the building's weight or the code specified wind loads as a means of assuring that a complete lateral-force-resisting system does exist in the structure.

In the 1994 *Provisions*, Sec. 2.2.6.1 required the use of amplified forces due to earthquake taken as  $0.4RE$  for the design of columns beneath discontinuous walls and frames as well as for the design of brittle elements. For 1997, the  $0.4RE$  has been changed to  $\rho E$ .

The requirements for minimum connections and continuity of the structure have been updated as have anchorage requirements to reflect lessons learned after the Northridge earthquake. In addition, the SDPG recommendation to delete  $C_a$  and replace it with a short period design spectral acceleration,  $S_{DS}$ , is implemented.

Requirements have been added for the design of collector elements in diaphragms to resist the maximum forces that they are likely to experience in an earthquake as opposed to the reduced forces for which the vertical elements of the lateral-force-resisting system are nominally designed.

#### **1994 Sec. 2.6/1997 Sec. 5.7, Combination of Load Effects**

The 1994 version of Sec. 2.2.6 required the use of overstrength for several conditions including columns beneath discontinuous lateral-force-resisting elements and certain unspecified "brittle" conditions. In the 1997 version, the requirements have been changed to require that overstrength be considered in the calculation of design seismic forces where specifically required by other sections of the *Provisions* rather than when so-called "brittle" conditions exist. Commentary provides discussion of other situations where consideration of structural overstrength in the design of elements would be appropriate.

The requirements for consideration of interaction effects between structural and nonstructural elements and for deformation compatibility for elements that are not part of the intended lateral-force-resisting system also have been strengthened and clarified.

In addition, the requirements to ensure both adequate deformation compatibility and the consideration of the interaction of rigid elements adjoining flexible frames have been clarified to point out that nonparticipating elements must be designed for the full moments, shears, and other forces imposed on them as a result of induced deformations equal to the design story drift and that the effect on these forces of the presence of rigid infills and other nonstructural elements must be considered when computing the forces. An exception is provided to permit elements provided with adequate ductile

detailing to be designed for reduced forces as if they were participating elements of the lateral-force-resisting system.

Additional guidance is provided concerning the modeling of certain concrete, masonry, and steel structures by requiring the application of more uniform modeling rules in the determination of drift so that the design of nonparticipating elements for deformation compatibility provides a more consistent level of protection.

Other changes have been made to implement the recommendations of the SDPG with respect to tying the the Seismic Design Categories (formerly termed Seismic Performance Categories) to the design spectra that incorporate site class effects. Special configuration rules within Seismic Design Categories C and D that increase the maximum permissible heights for structures with lateral-force-resisting systems comprised of braced frames and/or shear walls. The *1994 Provisions* permit increased height limits for such structures if the layout of the walls provides for adequate redundancy and torsional resistance. However, the *Provisions* are written in a manner that more closely relates to architectural layout than structural configuration and effectiveness. For example, rather than directly addressing whether or not the lines of resistance provide adequate torsional rigidity, the *Provisions* requires that the walls be located on the perimeter of the building. Such language is both highly restrictive and indirect with regard to the intended purpose. The revised language contained in this proposal relates directly to the distribution of lateral and torsional stiffness in the building and provides for greater design flexibility in its application.

#### **1994 Sec. 2.3.2.1/1997 Sec. 5.3.2.1, Calculation of Seismic Response Coefficient**

Changes are made to the base shear equations used in the equivalent lateral force analysis as required to accommodate the recommendations of the Seismic Design Procedures Group (SDPG); the term  $S_{DS}$  is substituted for the term  $2.5C_a$  used in the *1994 Provisions* to represent the demands on short period structures.  $S_{DS}$  represents the spectral acceleration at a period of 0.2 seconds, which in general is equivalent to  $2.5C_a$ , given the same assumptions with regard to fault characteristics, ground motion attenuation and design return period. In addition,  $1/T$  and  $1/T^2$  relationships, which are faithful to the true character of the typical response spectrum, are adopted; however, a modification to the standard response spectrum shape for structures in Seismic Design Categories E and F is introduced that is more representative of near-field spectra. Further, the Occupancy Importance Factor is integrated.

#### **1994 Sec. 2.3.3/1997 Sec. 5.3.3, Period Determination**

This section is modified to clarify that direct use of the approximate period is permitted. The title of 1994 Sec. 2.3.3.1 is corrected to indicate that the approximate period formula is applicable to structures of all types and coefficients are provided in the section for other types of structures. In addition, 1994 Table 2.3.3 is modified to accommodate the recommendations of the Seismic Design Procedures Group with regard to substitution of the quantity  $S_{Dl}$  for  $C_v$ .

#### **1994 Sec. 2.3.5/1997 Sec. 5.3.5, Horizontal Shear Distribution**

This section is modified to require that the amplification of the accidental component of torsional applies to the sum of computed torsion and accidental torsion when the equivalent lateral force technique is employed. The section also is modified to provide elements at the edges of torsionally irregular structures with the same level of protection against damage as that provided for all elements in regular buildings and structures.

### **1994 Sec. 2.3.7, 1997 Sec. 5.3.7, Drift Determination and P-Delta Effects**

This section is modified to emphasize the importance of considering the stiffening effects of adjoining rigid elements on the behavior of structural elements and incorporate guidelines for modeling of certain concrete, masonry, and steel structures.

Changes are made in 1994 Sec. 2.3.7.1/1997 Sec. 5.3.7.1 to require that for torsionally irregular structures, interstory drift be calculated at the edge of the structure rather than at the center of mass of the structure. The Occupancy Importance Factor is also integrated.

### **1994 Sec. 2.4/1997 Sec. 5.4, Modal Analysis Procedure**

In 1994 Sec. 2.4.2/1997 Sec. 5.4.2, changes are made that make the *Provisions* compatible with the level of analysis typically performed by today's design professional by updating the description of modal analysis to include three-dimensional modeling.

The changes made regarding base shear described above under the equivalent lateral force procedure are also reflected in 1994 Sec. 2.4.5/1997 Sec. 5.4.5.

### **1994 Sec. 2.4.9/1997 Sec. 5.4.9, Horizontal Shear Distribution**

This section is modified to indicate that the changes concerning amplification of torsion described above are not required for that portion of the torsion included in the dynamic analysis model.

### **1994 Sec. 2.6, Provisions for Seismically Isolated Structures, Sec. 2.7, Provisions for Nonbuilding Structures, and the Appendix to Chapter 2, Passive Energy Dissipation Systems**

As noted above, 1994 Sec. 2.4 has become Chapter 13, the 1994 Appendix to Chapter 2 has become an appendix to Chapter 13, and 1994 Sec. 2.7 has become Chapter 14.

## **1997 CHAPTER 6, ARCHITECTURAL, MECHANICAL, AND ELECTRICAL COMPONENTS AND SYSTEMS DESIGN REQUIREMENTS**

### **1994 Sec. 3.1/1997 Sec. 6.1, General**

The wording in Sec. 6.1 has been changed to more closely reflect to the intent of the *Provisions* and is more consistent with the *Seismic Use Group* terminology in Chapter 1. An exemption for all mechanical and electrical components weighing 20 pounds or less is added to be consistent with the *NEHRP Guidelines for the Seismic Rehabilitation of Buildings*.

The references are updated and modified to remove those that are covered in 1997 Chapter 14, Nonbuilding Structure Design Requirements.

The design equations and presentation and the values for  $a_p$  and  $R_p$  have been adjusted to be consistent with design forces in the 1997 *Uniform Building Code*.

Sec. 6.1.4 has been modified to correct editorial errors, add provisions for essential facilities to meet the performance goals for Group III buildings outlined in Sec. 1.4.3.6, stipulate a higher importance factor for storage racks in areas open to the public to provide an appropriate level of safety for rack installations in higher density occupancies, and clarify requirements for components that pose safety hazards.

New sections have been added to consolidate and clarify provisions for the design of component anchorage and to identify the minimum seismic requirements for inclusion in the construction documents that are to be specified by a registered design professional.

Sec. 6.2.3 has been modified to bring it into line with the 1997 *UBC*, to add some editorial clarifications, and to correct some errors in the 1994 *Provisions*. Sec. 6.2.6 has been changed to simplify suspended ceiling system requirements that reflect knowledge gained from recent earthquakes. Sec. 6.2.9 has been changed to refine the storage rack requirements to reflect performance observations after recent earthquakes. An expanded *Commentary* is also provided.

Sec. 6.3.7 has been modified to provide a cross-references to clarify the basis for required displacement calculations. Sec. 6.3.9 has been modified to clarify threshold values for at-grade storage tanks and delete some of the provisions concerning at-grade storage tanks that are now being treated in 1997 Chapter 14. Sec. 6.3.10 has been modified to clarify trigger importance values and other requirements. Sec. 6.3.11 has been revised to more clearly rely on national piping standards for the design and analysis of piping systems in cases where the seismic forces and displacements used are not less than those specified in the *Provisions*. Sec. 6.3.13 has been modified to limit the design of the equipment items themselves to only those components whose failure could result in a release of flammable or hazardous materials. Sec. 6.3.14 has been modified to relax requirements deemed to be too restrictive and not justified by past earthquake experience.

### **1997 CHAPTER 7, FOUNDATION DESIGN REQUIREMENTS**

New Sec. 7.5.3 is added to provide more specific requirements for dealing with the liquefaction hazard. The pile requirements in 1994 Sec. 4.5.3/1997 Sec. 7.5.4 have been clarified. In addition, *Commentary* has been added on horizontal ground displacement and mitigation of the liquefaction hazard and post-earthquake observations of retaining wall movements not associated with waterfront structures.

### **1997 CHAPTER 8, STEEL STRUCTURE DESIGN REQUIREMENTS**

The chapter has been revised significantly to reflect adoption of the 1997 version of the *AISC Seismic Provisions for Structural Steel Buildings* and the new *AISI Specification for the Design of Cold-Formed Steel Structural Members*.

### **1997 CHAPTER 9, CONCRETE STRUCTURE DESIGN REQUIREMENTS**

The chapter has been updated to reflect the 1995 edition of ACI-318. Other changes include the following: the addition of a requirement for both experimental evidence and analysis for precast elements has been added, clarification of the fact testing needs to verify capacities of only those portions of the system that will become elastic, separation of the diaphragm boundary element provisions from those of structural walls, the utilization of the entire wall cross section to resist factored gravity loads and factored overturning moments, an explicit limitation of the factored axial load on structural walls, the addition of rules for determining when special confinement becomes necessary at wall edges are added, the addition of an alternative methodology for establishing the need

for wall edge confinement, the limitation of confined concrete strain to reflect the degree of confinement required, the addition of a general procedure applicable to all shear wall configurations and a simple procedure for the common case of cantilever walls governed by flexural yielding at their base, the addition of explicit equations for the calculation of strain values, the addition of specific detailing requirements are given for shear wall boundary zones, and the addition of specific requirements for precast/prestressed structures in high seismic areas.

## **1997 CHAPTER 10, COMPOSITE STEEL AND CONCRETE STRUCTURE DESIGN REQUIREMENTS**

A major change to the chapter reflects the fact that detailed design requirements in the 1997 edition are now included by reference to the American Institute of Steel Construction's *Seismic Provisions for Structural Steel Buildings*. In particular, the 1997 AISC Seismic Provisions include a new section, "Part II - Composite Structural Steel and Reinforced Concrete Buildings," that was developed in coordination with the 1997 NEHRP update process. Thus, the AISC Part II seismic provisions are consistent with the 1997 update to the requirements for composite steel-concrete structures that were first introduced into the 1994 NEHRP Provisions. In referencing the AISC seismic provisions, new language has been added to require special review for the use of composite systems in Seismic Design Categories D and above.

Specific changes include the addition of several new composite seismic system categories and revision of requirements to maintain consistency with provisions for steel and reinforced concrete structures and to reflect the SDPG recommendation that detailing and design rules be applied consistently to all systems with the same  $R$  value. Changes to system categories and design requirements include the following: introduction of a new composite intermediate moment frame category based on a similar new system for steel structures with related modification of requirements for the existing composite ordinary and special moment frames and modification of usage restrictions for the three frame types to make them comparable to those for reinforced concrete frames; introduction of a new composite ordinary braced frame category intended for use in Seismic Design Categories A through C with related changes to requirements for composite concentrically and eccentrically braced frames, which are primarily intended for use in Seismic Design Categories D and above; and division of the reinforced concrete shear walls composite with structural steel elements category has been split into two categories that include the designations ordinary and special (a change made to consistent with comparable changes made for reinforced concrete shear wall systems).

The detailing rules for composite members have been revised to be consistent with the three basic categories of seismic performance termed ordinary, intermediate, and special. Some additional technical changes made to the member design requirements include: a relaxation of  $D/t$  limits for concrete filled round tubes, more stringent requirements for moment connections in composite special moment frames, and new cautionary language concerning the transition of composite to reinforced concrete columns.

## **1997 CHAPTER 11, MASONRY STRUCTURE DESIGN REQUIREMENTS**

As noted above, the masonry structure design requirements in 1994 Chapter 8 have been relocated to 1997 Chapter 11. In general, requirements have been revised to improve clarity or to correct prior inconsistencies and errors. Much like the 1994 masonry provisions, the 1997 provisions represent a true strength design of masonry. The basic design approach and fundamental concepts have not been changed.

The primary reference document for the 1997 provisions has been updated to the 1995 Masonry Standards Joint Committee (MSJC) requirements.

Masonry shear wall types have been categorized and given names that define the design approach (“plain” for designs neglecting reinforcement or “reinforced” for designs considering reinforcement) and the need for prescriptive reinforcement (“ordinary” for no prescriptive reinforcement, “detailed” or “intermediate” for walls with minimum reinforcement per the former Seismic Design Category C requirements, and “special” for walls with minimum reinforcement per the former Seismic Design Category D and E requirements). These new classifications are given to provide direct linkages with design and detailing requirements and  $R$ ,  $\phi$  and  $C_d$  factors in 1997 Table 5.2.2.

Maximum amounts of longitudinal reinforcement in reinforced masonry flexural members have been increased. The requirements contained in 1994 Sec. 8.6.2.2 have been relaxed by using a much smaller curvature for out-of-plane bending, toe compressive strains larger than the previous value of 0.002, and a rectangular stress block rather than a triangular distribution of compressive stress. The revised criterion is less restrictive than that given in the 1997 *UBC* for the typical range of axial compressive stress. Because longitudinal reinforcement is limited based on an ultimate masonry compressive strain, a large inelastic strain in tensile reinforcement and the level of axial compressive stress, actual masonry compressive strains cannot exceed peak values. Thus, requirements for confinement steel in reinforced masonry shear walls have been eliminated in the 1997 *Provisions*. Furthermore, because curvature ductility can be ensured despite the level of axial force, capacity reduction factors for combinations of axial load and flexure have been set equal to that for flexure alone.

No criteria had been given in the 1994 *Provisions* for maximum spacing of vertical reinforcement in masonry walls in Seismic Design Category C. A maximum spacing is specified at 4'-0" in the 1997 *Provisions* which is consistent with the 1997 *UBC* and per the 1995 MSJC code for walls not part of the lateral-force system.

Requirements for wall frames have been modified to be consistent with the 1997 *UBC* design requirements.

Provisions for the design of anchors in masonry have been revised to separate pull-out strengths for headed and bent-bar anchors. This revision removes the excessive conservatism for headed anchors that was formerly limited by the pullout strength of bent-bar anchors.

Design requirements for glass-unit masonry and masonry veneer per Chapters 11 and 12 of the 1995 MSJC code have been adopted by reference.

The 1994 Appendix to Chapter 8 has been shortened appreciably to form the 1997 Appendix to Chapter 11 by making reference to Chapter 10 of the 1995 MSJC requirements. These requirements constitute the same pseudo-strength design method as introduced in the 1991 *Provisions* masonry design requirements that were moved to the 1994 Appendix.



## 1997 CHAPTER 12, WOOD STRUCTURE DESIGN REQUIREMENTS

The wood structures chapter for the *Provisions* has been thoroughly reorganized and revised for the 1997 Edition. The sections have been reordered in an effort to make the chapter similar to that used in the other material chapters. The AF&PA/ASCE 16-95 *Standard for Load and Resistance Factor Design (LRFD) for Engineering Wood Construction* has been adopted as the reference standard for design and the soft conversion factors for use with allowable stress design have been moved to the *Commentary*. In addition, requirements related to Seismic Design Categories have been considered in three groups (i.e., A; B, C, and D; and E and F) in order to show that the detailing for wood structures is directly related to the structural system used rather than to the Seismic Design Category.

The engineered construction requirements have been changed significantly. Deformation compatibility requirements have been added and framing requirements, modified. The definition of aspect ratio for diaphragms has been clarified as have requirements concerning the horizontal distribution of shear. Anchorage requirements for shear walls also have been modified to require that steel plate washers be used instead of standard cut washers. Many of these changes reflect lessons learned after the 1994 Northridge earthquake.

The diaphragm and shear wall requirements also have been changed. The definition of aspect ratio for shear walls has been clarified. In addition, the capacities for shear walls have been reduced by 10 percent to account for the effects of cyclic loading in response to the racking damage observed after the Northridge earthquake. Note that diaphragm capacities have not been reduced since the since similar damage was not observed.

Conventional construction requirements have been significantly expanded in an effort to illustrate when structures should be engineered. Irregular structure examples with maximum dimensions for conventional construction (including setbacks, offset floors, stepped footings, and openings in diaphragms) have been added. Detailing examples for stepped footings and openings in diaphragms also have been added to illustrate how forces around these irregularities might be transferred. Details for transferring forces in truss roof systems to the shear walls have been added to the *Commentary* since transfer of these forces often is overlooked. The exception to allow wood framing to resist lateral forces associated with masonry construction has been expanded to allow an additional story of masonry veneer for structures that have either increased the required structural sheathing by 50 percent or include masonry or concrete shear walls on the first story above grade.

## 1997 CHAPTER 13, SEISMICALLY ISOLATED STRUCTURE DESIGN REQUIREMENTS

The base isolation provisions have been fully updated to be consistent with 1997 *Uniform Building Code*<sup>1</sup> design requirements and other improvements and to be consistent with the new seismic design procedures adopted for the 1997 *Provisions*<sup>2</sup>. Second, the 1994 Energy Dissipation Systems appendix has been deleted since its provisions were deemed to be insufficient for design and regulation. Instead, it has been replaced by only a few paragraphs giving only very general guidance concerning use of such systems. It is anticipated that during the effort to update the 1997 *Provisions* for re-issuance in 2000, a concerted effort will be made to develop up-to-date criteria covering energy dissipation systems.

## **1997 CHAPTER 14, NONBUILDING STRUCTURE DESIGN REQUIREMENTS**

As indicated above, the nonbuilding structures requirements which appeared as 1994 Sec. 2.6 now appears as 1997 Chapter 14 and the requirements have been expanded and modified to reflect the new design procedures for the 1997 *Provisions*. An appendix is included to provide the user with considerable extra guidance concerning nonbuilding structures for which no formal standards exist. *Commentary* changes have been made to reflect the *Provisions* changes.

**COMPARISON OF THE CONTENTS OF THE  
1994 AND 1997 EDITIONS OF THE *PROVISIONS***

**Changes from the 1994 to the 1997 Edition  
shown in underline and strikeout**

Chapter 1 GENERAL PROVISIONS

1.1 Purpose

1.2 Scope and Application

1.2.1 Scope

Exception 1

Exception 2

Exception 3

Exception 4

~~1.3 Application of Provisions~~

~~1.3.1 New Buildings~~

~~1.2.2 1.3.2 Additions to Existing Buildings~~

~~1.2.2.1 1.3.2.1~~

~~1.2.2.2 1.3.2.2~~

~~1.2.3 1.3.3 Change of Use~~

Exception

1.2.4 Alterations

~~1.2.4 1.5 Alternate~~ Alternative Materials and Alternate Means and Methods of Construction

*1994 Sec. 1.4, 1.4.1, 1.4.2 moved to 1997 Chapter 4*

~~1.3 1.4.3 Seismic Use Hazard Exposure Groups~~

~~1.3.1 1.4.3.1 Group III~~

~~1.3.2 1.4.3.2 Group II~~

~~1.3.3 1.4.3.3 Group I~~

~~1.3.4 1.4.3.4 Multiple Use~~

~~1.3.5 1.4.3.5 Group III Building Protected Structure Access Protection~~

~~1.4.3.6 Group III Function~~

*1994 Sec. 1.6 moved to 1997 Chapter 3*

1.4 Occupancy Importance Factor

~~Appendix to Chapter 1 DEVELOPMENT OF DESIGN VALUE MAPS~~

~~Maps 5 through 15~~

Chapter 2 GLOSSARY AND NOTATIONS

2.1 Glossary

2.2 Notations

Chapter 3 QUALITY ASSURANCE

1.6 Quality Assurance

3.1 Scope

3.2 1.6.1 Quality Assurance Plan

Exceptions 1, 2, 3, and 4

3.2.1 1.6.1.1 Details of Quality Assurance Plan

3.2.2 1.6.1.2 Contractor Responsibility

3.3 1.6.2 Special Inspection

3.3.1 1.6.2.1 Foundations Piers, Piles, Caissons

3.3.1.6.2.2 Reinforcing Steel

3.3.1.6.2.2.1

3.3.1.6.2.2.2

3.3.1.6.2.3 Structural Concrete

3.3.1.6.2.4 Prestressed Concrete

3.3.1.6.2.5 Structural Masonry

3.3.1.6.2.5.1

3.3.1.6.2.5.2

3.3.1.6.2.6 Structural Steel

3.3.1.6.2.6.1

Exception

3.3.1.6.2.6.2

3.3.1.6.2.7 Structural Wood

3.3.1.6.2.7.1

3.3.1.6.2.7.2

3.3.8 Cold-Formed Steel Framing

3.3.8.1

3.3.8.2

3.3.9 1.6.2.8 Architectural Components

Item 1

Exceptions a and b

Item 2

3.3.10 1.6.2.9 Mechanical and Electrical Components

3.3.11 Seismic Isolation System

3.4 1.6.3 Testing

3.4.1.6.3.1 Reinforcing and Prestressing Steel

3.4.1.6.3.1.1

3.4.1.6.3.1.2

3.4.1.6.3.1.3

3.4.1.6.3.2 Structural Concrete

3.4.1.6.3.3 Structural Masonry

3.4.1.6.3.4 Structural Steel

3.4.1.6.3.4.1

1.6.3.4.2

1.6.3.4.3

3.4.1.6.3.5 Mechanical and Electrical Equipment

- 3.4-6.3.6 Seismically Isolated Structures
- 3.5 Structural Observations
- 3.6 1.6.4 Reporting and Compliance Procedures

Chapter 4 GROUND MOTION

4.1 1.4 Seismic Performance Procedures for Determining Maximum Considered Earthquake and Design Earthquake Ground Motion Accelerations and Response Spectra

- Map 1 Maximum Considered Earthquake Ground Motion for the United States of 0.2 sec Spectral Response Acceleration
- Map 2 Maximum Considered Earthquake Ground Motion for the United States of 1.0 sec Spectral Response Acceleration
- Map 3 Maximum Considered Earthquake Ground Motion for California/Nevada of 0.2 sec Spectral Response Acceleration
- Map 4 Maximum Considered Earthquake Ground Motion for California/Nevada of 1.0 sec Spectral Response Acceleration
- Map 5 Maximum Considered Earthquake Ground Motion for the Southern California Area of 0.2 sec Spectral Response Acceleration
- Map 6 Maximum Considered Earthquake Ground Motion for the Southern California Area of 1.0 sec Spectral Response Acceleration
- Map 7 Maximum Considered Earthquake Ground Motion for the San Francisco Bay Area of 0.2 sec Spectral Response Acceleration
- Map 8 Maximum Considered Earthquake Ground Motion for the San Francisco Bay Area of 1.0 sec Spectral Response Acceleration
- Map 9 Maximum Considered Earthquake Ground Motion for the Pacific Northwest of 0.2 sec Spectral Response Acceleration
- Map 10 Maximum Considered Earthquake Ground Motion for the Pacific Northwest of 1.0 sec Spectral Response Acceleration
- Map 11 Maximum Considered Earthquake Ground Motion for Salt Lake City and the Intermountain Area of 0.2 sec Spectral Response Acceleration
- Map 12 Maximum Considered Earthquake Ground Motion for Salt Lake City and the Intermountain Area of 1.0 sec Spectral Response Acceleration
- Map 13 Maximum Considered Earthquake Ground Motion for the New Madrid Area of 0.2 sec Spectral Response Acceleration
- Map 14 Maximum Considered Earthquake Ground Motion for the New Madrid Area of 1.0 sec Spectral Response Acceleration
- Map 15 Maximum Considered Earthquake Ground Motion for the Charleston, South Carolina, Area of 0.2 sec Spectral Response Acceleration
- Map 16 Maximum Considered Earthquake Ground Motion for the Charleston, South Carolina, Area of 1.0 sec Spectral Response Acceleration
- Map 17 Maximum Considered Earthquake Ground Motion for Alaska at 0.2 sec Spectral Response Acceleration
- Map 18 Maximum Considered Earthquake Ground Motion for Alaska at 1.0 sec Spectral Response Acceleration

- Map 19 Maximum Considered Earthquake Ground Motion for Hawaii at 0.2 sec Spectral Response Acceleration
- Map 20 Maximum Considered Earthquake Ground Motion for Hawaii at 1.0 sec Spectral Response Acceleration
- Map 21 Maximum Considered Earthquake Ground Motion for Puerto Rico, Culebra, St. Thomas, Vieques, and St. Croix at 0.2 sec Spectral Response Acceleration
- Map 22 Maximum Considered Earthquake Ground Motion for Puerto Rico, Culebra, St. Thomas, Vieques, and St. Croix at 1.0 sec Spectral Response Acceleration
- Map 23 Maximum Considered Earthquake Ground Motion for Guam and Tutuila at 0.2 sec Spectral Response Acceleration
- Map 24 Maximum Considered Earthquake Ground Motion for Guam and Tutuila at 1.0 sec Spectral Response Acceleration

4.1.1 Maximum Considered Earthquake Ground Motion

1.4.1 Seismic Ground Acceleration Maps

- Map 1, Map for coefficient  $A_n$
- Map 2, Map for coefficient  $A_r$
- Map 3, Contour map for coefficient  $A_n$
- Map 4, Contour map for coefficient  $A_r$

1.4.1.1

- Table 1.4.1.1 Coefficients  $A_n$  and  $A_r$

1.4.1.2

4.1.2 1.4.2 Seismic Coefficients General Procedure for Determining Maximum Considered Earthquake and Design Spectral Response Acceleration

4.1.2.1 Site Class Definitions

4.1.2.2 1.4.2.1 Steps for Classifying a Site

Table 4.1.2.2 1.4.2.1 Soil Profile Type Site Classification

4.1.2.3 1.4.2.2 Definitions of Site Class Parameters

4.1.2.3 1.4.2.3 Site Coefficients and Adjusted Maximum Considered Earthquake Spectral Response Acceleration Parameters

Table 4.1.2.4a 1.4.2.3a Values of  $F_a$  as a Function of Site Class and Mapped Short Period Maximum Considered Earthquake Spectral Acceleration Conditions and Shaking Intensity

Table 4.1.2.4b 1.4.2.3a Values of  $F_v$  as a Function of Site Class and Mapped 1 Second Period Maximum Considered Earthquake Spectral Acceleration Conditions and Shaking Intensity

1.4.2.4 Seismic Coefficients  $C_n$  and  $C_r$

- Table 1.4.2.4a, Seismic Coefficient  $C_n$

- Table 1.4.2.4b, Seismic Coefficient  $C_r$

4.1.2.5 Design Spectral Response Acceleration Parameters

4.1.2.6 General Procedure Response Spectrum

4.1.3 Site-Specific Procedure for Determining Ground Motion Accelerations

4.1.3.1 Probabilistic Maximum Considered Earthquake Exception

4.1.3.2 Deterministic Limit on Maximum Considered Earthquake Ground Motion

4.1.3.3 Deterministic Maximum Considered Earthquake Ground Motion

- 4.1.3.5 Site-Specific Design Ground Motion
- 4.2.1.4.4 Seismic Design Performance Category  
Table 4.2.1.4.4 Seismic Performance Category
- 4.2.1 Determination of Seismic Design Category  
Table 4.2.1a Seismic Design Category Based on Short Period Response Accelerations  
Table 4.2.1b Seismic Design Category Based on 1 Second Period Response Accelerations
- 4.2.2.1.4.5 Site Limitation for Seismic Design Performance Category Categories E and F  
Exception

~~Chapter 5 Chapter 2~~ STRUCTURAL DESIGN CRITERIA, ANALYSIS, AND PROCEDURES

- 5.2.1 Reference Document
- 5.2.2 Structural Design Requirements
  - 5.2.2.1 Design Basis
    - 5.2.2.1 General
    - 5.2.2.2 Structural Framing Systems Basic Seismic-Force-Resisting System  
Table 5.2.2.2 Structural Systems (see separate legal-size sheet for 1997 version)
      - 5.2.2.2.1 Dual System
      - 5.2.2.2.2 Combinations of Framing Systems
        - 5.2.2.2.2.1 Combination Framing Factor  $R$  and  $\rho$  Factors  
Exceptions 1 and 2
        - 5.2.2.2.2.2 Combination Framing Detailing Requirements
        - 5.2.2.2.3 Seismic Performance Design Categories A, B, and C
        - 5.2.2.2.4 Seismic Performance Design Category D and E
          - 5.2.2.2.4.1 Limited Building Height
          - 5.2.2.2.4.2 Interaction Effects
          - 5.2.2.2.4.3 Deformational Compatibility  
Exception
          - 5.2.2.2.4.4 Special Moment Frames
        - 5.2.2.2.5 Seismic Performance Design Category E and F
      - 5.2.2.3 Structure Building Configuration
        - 5.2.2.3.1 Diaphragm Flexibility
          - 5.2.2.3.1.2 Plan Irregularity  
Table 5.2.2.3.1.2 Plan Structural Irregularities
          - 5.2.2.3.2 Vertical Irregularity  
Exceptions 1 and 2  
Table 5.2.2.3.2 Vertical Structural Irregularities
      - 5.2.4 Redundancy
        - 5.2.4.1 Seismic Design Categories A, B, and C
        - 5.2.4.2 Seismic Design Category D  
Exception
        - 5.2.4.3 Seismic Design Categories E and F  
Exception
        - 5.2.4.5 Analysis Procedures
          - 5.2.2.5.4.1 Seismic Performance Design Category A

- 52.2.54.2 Seismic Performance Design Categories B and C
- 52.2.54.3 Seismic Performance Design Categories D, and E, and F
  - Table 52.2.54.3 Analysis Procedures for Seismic Performance Design Categories D, and E, and F
- 5.2.5.4 Diaphragms
- 52.2.56 Design, Detailing Requirements, and Structural Component Load Effects
- 52.2.65.1 Seismic Performance Design Category A
  - 5.2.6.1.1 Component Load Effects
  - 52.2.65.1.12 Connections
  - 52.2.65.1.23 Anchorage of Concrete or Masonry Walls
  - 2.2.5.1.3 Anchorage of Nonstructural Systems
  - 52.2.65.2 Seismic Performance Design Category B
    - 52.2.65.2.1 Second-Order Component Load Effects
    - 52.2.65.2.2 Openings
    - 2.2.5.2.3 Orthogonal Effects
    - 52.2.65.2.43 Discontinuities in Vertical System
      - Exception
      - 52.2.65.2.54 Nonredundant Systems
      - 52.2.65.2.65 Collector Elements
      - 52.2.65.2.76 Diaphragms
      - 52.2.65.2.87 Bearing Walls
      - 52.2.65.2.98 Inverted Pendulum-Type Structures
    - 5.2.6.2.9 Anchorage of Nonstructural Systems
    - 5.2.6.2.10 Columns Supporting Discontinuous Walls or Frames
  - 52.2.65.3 Seismic Performance Design Category C
    - 52.2.65.3.1 Plan Irregularity
    - 5.2.6.3.2 Collector Elements
      - Exception
      - 5.2.6.3.3 Anchorage of Concrete or Masonry Walls
    - 52.2.65.4 Seismic Performance Categories Design Category D and E
      - 52.2.65.4.1 Orthogonal Load Effects
      - 5.2.6.4.2 Collector Elements
        - Exception
        - 52.2.65.4.23 Plan or Vertical Irregularities
        - 52.2.65.4.34 Vertical Seismic Forces
      - 5.2.6.5 Seismic Design Categories E and F
        - 5.2.6.5.1 Plan or Vertical Irregularities
      - 52.2.76 Combination of Load Effects
        - Eq. 2.2.6-1 5.2.7-1
        - Eq. 2.2.6-2 5.2.7-2
      - 5.2.7.1 Special Combination of Loads
        - Eq. 2.2.6-3 5.2.7.1-1
        - Eq. 2.2.6-4 5.2.7.1-2
    - 52.2.78 Deflection and Drift Limits
      - Table 5.2.8-2.2.7 Allowable Story Drift, *a*



52.3 Equivalent Lateral Force Procedure

52.3.1 General

52.3.2 Seismic Base Shear

Eq. ~~52.3.2-1~~

52.3.2.1 Calculation of Seismic Response Coefficient

Eq. 52.3.2.1-1

~~Eq. 2.3.2.1-2~~

Eq. 5.3.2.1-2

Eq. 5.3.2.1-3

Eq. 5.3.2.1-4

52.3.3 Period Determination

Table 52.3.3 Coefficient for Upper Limit on Calculated Period

52.3.3.1 Approximate Fundamental Period for ~~Concrete and Steel Moment Resisting Frame~~  
Buildings

Eq. 52.3.3-1

Eq. 52.3.3-2

52.3.4 Vertical Distribution of Seismic Forces

Eq. 52.3.4-1

Eq. 52.3.4-2

52.3.5 Horizontal Shear Distribution

Eq. 52.3.5

52.3.5.1 Torsion

5.3.5.2 Accidental Torsion

5.3.5.3 Dynamic Amplification of Torsion

Eq. ~~2.3.5-1~~ 5.3.5.3

52.3.6 Overturning

Eq. 52.3.6

52.3.7 Drift Determination and *P*-delta Effects

52.3.7.1 Story Drift Determination

Eq. 52.3.7.1

52.3.7.2 P-Delta Effects

Eq. 52.3.7.2-1

Eq. 52.3.7.2-2

52.4 Modal Analysis Procedure

52.4.1 General

52.4.2 Modeling

52.4.3 Modes

52.4.4 ~~Periods~~ Modal Properties

52.4.5 Modal Base Shear

Eq. 52.4.5-1

Eq. 52.4.5-2

Eq. 52.4.5-3

Exceptions ~~1 and 2~~

Eq. 52.4.5-4

Exception 3

- Eq. 52.4.5-5
- 52.4.6 Modal Forces, Deflections, and Drifts
  - Eq. 52.4.6-1
  - Eq. 52.4.6-2
  - Eq. 52.4.6-3
  - Eq. 52.4.6-4
- 52.4.7 Modal Story Shears and Moments
- 52.4.8 Design Values
  - Eq. 52.4.8
  - Exception
- 52.4.9 Horizontal Shear Distribution
- 52.4.10 Foundation Overturning
- 52.4.11 *P*-delta Effects
- 52.5 Soil-Structure Interaction Effects
  - 52.5.1 General
  - 52.5.2 Equivalent Lateral Force Procedure
    - 52.5.2.1 Base Shear
      - Eq. 52.5.2.1-1
      - Eq. 52.5.2.1-2
    - 52.5.2.1.1 Effective Building Period
      - Eq. 52.5.2.1.1-1
      - Eq. 52.5.2.1.1-2
      - Table 52.5.2.1.1 Values of  $G/G_o$  and  $v_s/v_{so}$
      - Eq. 52.5.2.1.1-3
      - Eq. 52.5.2.1.1-4
      - Eq. 52.5.2.1.1-5
      - Eq. 52.5.2.1.1-6
    - 52.5.2.1.2 Effective Damping
      - Eq. 52.5.2.1.2-1
      - Figure 52.5.2.1.2 Foundation damping factor
      - Eq. 52.5.2.1.2-2
      - Eq. 52.5.2.1.2-3
      - Exception
      - Eq. 52.5.2.1.2-4
  - 52.5.2.2 Vertical Distribution of Seismic Forces
  - 52.5.2.3 Other Effects
    - Eq. 52.5.2.3
  - 52.5.3 Modal Analysis Procedure
    - 52.5.3.1 Modal Base Shears
      - Eq. 52.5.3.1-1
      - Eq. 52.5.3.1-2
    - 52.5.3.2 Other Modal Effects
      - Eq. 52.5.3.2-1
      - Eq. 52.5.3.2-2
    - 52.5.3.3 Design Values

1996 Sec. 2.6 moved to 1997 Chapter 13

1994 Sec. 2.7 moved to 1997 Chapter 14

1994 Appendix to Chapter 2 moved to 1997 Appendix to Chapter 13

~~Chapter 6~~ ~~Chapter 3~~ ARCHITECTURAL, MECHANICAL, AND ELECTRICAL  
COMPONENTS AND SYSTEMS DESIGN REQUIREMENTS

~~63.1~~ General

Exception

Exception 1

Exception 2

Exception 3

Exception 4

Exception ~~4~~ 5

Exception 6

~~63.1.1~~ References and Standards

~~6.1.1.1~~ Consensus Standards

Ref. ~~3-1 through 3-16~~ 6-1 through 6-12

~~6.1.1.2~~ Accepted Standards

Ref. 6-13 through 6-18

~~63.1.2~~ Component Force Transfer

~~63.1.3~~ Seismic Forces

Eq. ~~63.1.3-1 through 63.1.3-5~~

~~63.1.4~~ Seismic Relative Displacements

Eq. ~~63.1.4-1 through 63.1.4-4~~

~~63.1.5~~ Component Importance Factor

~~6.1.6~~ Component Anchorage

~~6.1.6.1 through 6.1.6.7~~

~~6.1.7~~ Construction Documents

Table 6.1.7 Construction Documents

~~63.2~~ Architectural Component Design

~~63.2.1~~ General

~~63.2.2~~ Architectural Component Forces and Displacements

Table ~~63.2.2~~ Architectural Component Coefficients

~~63.2.3~~ Architectural Component Deformation

~~63.2.4~~ Exterior Wall Panel Connections

~~63.2.5~~ Out-of-Plane Bending

~~63.2.6~~ Suspended Ceilings

~~63.2.6.1~~ Seismic Forces

~~3.2.6.2~~ Installation

~~63.2.6.32~~ Industry Standard Construction

~~63.2.6.32.1~~ Seismic Design Category C

~~63.2.6.32.2~~ Seismic Design Categories D, E, and F

- 3.2.6.3.3
- ~~63.2.6.4 Unbraced Construction~~
- ~~63.2.6.4.1~~
  - ~~Eq. 63.2.6.4.1-1~~
  - ~~Eq. 63.2.6.4.1-2~~
- ~~63.2.6.4.2~~
  - ~~Eq. 63.2.6.4.2-1~~
  - ~~Eq. 63.2.6.4.2-2~~
- ~~63.2.6.5 Braced Construction~~
- ~~63.2.6.5.1~~
- ~~63.2.6.5.2~~
- ~~63.2.6.5.3~~
- 63.2.6.63 Integral Ceiling/Sprinkler Construction
- ~~63.2.6.7 Partitions~~
- 63.2.7 Access Floors
  - 63.2.7.1 General
  - 63.2.7.2 Special Access Floors
- 63.2.8 Partitions
- 63.2.9 Steel Storage Racks
- ~~3.2.9.1 At-Grade Elevation~~
- ~~3.2.9.2 Above-Grade Elevations~~
- 63.3 Mechanical and Electrical Component Design
  - 63.3.1 General
  - 63.3.2 Mechanical and Electrical Component Forces and Displacements
    - Table 63.3.2, Mechanical and Electrical Components Coefficients
  - 63.3.3 Mechanical and Electrical Component Period
    - Eq. 63.3.3
  - 63.3.4 Mechanical and Electrical Component Attachments
  - 63.3.5 Component Supports
  - 63.3.6 Component Certification
  - 63.3.7 Utility and Service Lines at Building Interfaces
  - 63.3.8 Site-Specific Considerations
  - 63.3.9 Storage Tanks
    - ~~3.3.9.1 Above-Grade Storage Tanks~~
    - ~~3.3.9.2 At-Grade Storage Tanks~~
  - 63.3.10 HVAC Ductwork
  - 63.3.11 Piping Systems
    - ~~63.3.11.1 Pressure Piping Systems~~
      - ~~63.3.11.21 Fire Protection Sprinkler Systems~~
      - ~~63.3.11.32 Other Piping Systems~~
        - ~~63.3.11.42.1 Supports and Attachments for Other Piping~~
    - 63.3.12 Boilers and Pressure Vessels
      - 63.3.12.1 ASME Boilers and Pressure Vessels
      - 63.3.12.2 Other Boilers and Pressure Vessels
      - 63.3.12.3 Supports and Attachments for Boilers and Pressure Vessels

- 63.3.13 Mechanical Equipment, Attachments, and Supports
  - 63.3.13.1 Mechanical Equipment
  - 63.3.13.2 Attachments and Supports for Mechanical Equipment
    - Exception
  - 63.3.14 Electrical Equipment, Attachments, and Supports
    - 63.3.14.1 Electrical Equipment
    - 63.3.14.2 Attachments and Supports for Electrical Equipment
  - 63.3.15 Alternative Seismic Qualification Methods
  - 63.3.16 Elevator Design Requirements
    - 3.3.16.1 Elevators and Hoistway Structural System
    - 63.3.16.2 Elevator Machinery and Controller Supports and Attachments
    - 63.3.16.3 Seismic Controls
    - 63.3.16.4 Retainer Plates

Chapter 7 ~~Chapter 4~~ FOUNDATION DESIGN REQUIREMENTS

- 74.1 General
- 74.2 Strength of Components and Foundations
  - 74.2.1 Structural Materials
  - 74.2.2 Soil Capacities
- 74.3 Seismic Design Performance Categories A and B
- 74.4 Seismic Design Performance Category C
  - 74.4.1 Investigation
  - 74.4.2 Pole-Type Structures
  - 74.4.3 Foundation Ties
  - 74.4.4 Special Pile Requirements
    - 74.4.4.1 Uncased Concrete Piles
    - 74.4.4.2 Metal-Cased Concrete Piles
      - Exception
    - 74.4.4.3 Concrete-Filled Pipe
    - 74.4.4.4 Precast Concrete Piles
    - 74.4.4.5 Precast-Prestressed Piles
  - 74.5 Seismic Design Performance Categories D, and E, and F
    - 74.5.1 Investigation
    - 74.5.2 Foundation Ties
    - 7.5.3 Liquefaction Potential and Soil Strength Loss
      - 74.5.43 Special Pile Requirements
        - 74.5.43.1 Uncased Concrete Piles
        - 74.5.43.2 Metal-Cased Concrete Piles
          - Exception
        - 74.5.43.3 Precast Concrete Piles
        - 74.5.43.4 Precast-Prestressed Piles
        - 74.5.43.5 Steel Piles

Chapter 8 ~~Chapter 5~~ STEEL STRUCTURE DESIGN REQUIREMENTS

85.1 Reference Documents

Ref. ~~85-1~~ through ~~8-7~~ ~~5-8~~

85.2 ~~Structural Steel~~ Design Seismic Requirements for Steel Structures

~~5.6~~ Seismic Provisions for Steel Structural Members

8.3 ~~5.6.1~~ Seismic Performance Design Categories A, and B, and C

~~85.6.2~~ Seismic Performance Design Category C

8.4 ~~5.6.3~~ Seismic Performance Design Categories D, and E, and F

8.5 ~~5.3~~ Cold-Formed Steel Seismic Requirements

8.5.1 ~~5.3.1~~ Ref. ~~5-4~~ Modifications to Ref. 8-4

~~5.3.2~~ Ref. ~~5-4~~

8.5.2 ~~5.3.3~~ Ref. ~~5-5~~ Modifications to Ref. 8-5

~~5.3.4~~ Ref. ~~5-6~~

8.6 ~~5.7~~ Light Framed Walls

8.6.1 ~~5.7.1~~ Boundary Members

8.6.2 ~~5.7.2~~ Connections

8.6.3 ~~5.7.3~~ Braced Bay members

8.6.4 ~~5.7.4~~ Diagonal Braces

8.6.5 Shear Walls

Table 8.6 Nominal Shear Values for Seismic Forces for Shear Walls Framed with Cold-Formed Steel Studs

8.7 ~~5.4~~ Seismic Requirements for Steel Deck Diaphragms

8.8 ~~5.5~~ Steel Cables

Chapter 9 ~~Chapter 6~~ CONCRETE STRUCTURE DESIGN REQUIREMENTS

96.1 Reference Documents

Ref. 6-1

Ref. 6-2

96.1.1 Modifications to Ref. 6-1

96.1.1.1

9.1.1.2

96.1.1.23

96.1.1.34

96.1.1.45

96.1.1.56

96.1.1.67

96.1.1.78

96.1.1.89

~~6.1.1.9~~

96.1.1.10

96.1.1.11

9.1.1.12

9.1.1.13

96.1.1.1214

- 6.1.1.13
- 9.1.1.15
- 96.1.1.1416
- ~~6.1.2 Modifications to Ref. 6-2~~
- ~~96.1.2.1~~
- 96.2 Bolts and Headed Stud Anchors in Concrete
- 96.2.1 Load Factor Multipliers
- 96.2.2 Strength of Anchors
- 96.2.3 Strength Based on Tests
- 96.2.4 Strength Based on Calculations
- 96.2.4.1 Strength in Tension
  - Eq. 96.2.4.1-1
  - Eq. 96.2.4.1-2
  - Figure 96.2.4.1a Shear cone failure for a single headed anchor
  - Eq. 96.2.4.1-3
  - Figure 96.2.4.1b Truncated pyramid failure for a group of headed anchors
  - Figure 96.2.4.1c Pull-out failure surface for a group of headed anchors in tension
- 96.2.4.2 Strength in Shear
  - Eq. 96.2.4.2-1 through 96.2.4.2-68
  - Figure 96.2.4.2 Shear on a group of headed anchors
- 96.2.4.3 Combined Tension and Shear
  - Eq. 96.2.4.3-1a and 1b through 96.2.4.3-2a and 2b
- 9.3 Classification of Seismic-Force-Resisting Systems
- 96.3.1 Classification of Moment Frames
- 96.3.1.1 Ordinary Moment Frames
  - 9.3.1.1.1
  - 9.3.1.1.2
- 96.3.1.2 Intermediate Moment Frames
- 96.3.1.3 Special Moment Frames
- 9.3.2 Classification of Shear Walls
- 9.3.2.1 Ordinary Plain Concrete Shear Walls
- 9.3.2.2 Detailed Plain Concrete Shear Walls
- 9.3.2.3 Ordinary Reinforced Concrete Shear Walls
- 9.3.2.4 Special Reinforced Concrete Shear Walls
- 96.4 Seismic Performance Design Category A
- 96.5 Seismic Performance Design Category B
  - ~~96.5.1 Ordinary Moment Frames~~
  - 96.5.21 Moment Frames
- 96.6 Seismic Performance Design Category C
- 9.6.1 Seismic-Force-Resisting Systems
- 96.6.1.1 Moment Frames
- 9.6.1.2 Shear Walls
- 96.6.2 Discontinuous Members
- 96.6.3 Plain Concrete
  - 96.6.3.1 Walls

96.6.3.2 Footings

Exceptions

96.6.3.3 Pedestals

96.7 Seismic Performance Design Categories D, and E, or F

9.7.1 Seismic-Force-Resisting Systems

96.7.1.1 Moment Frames

9.7.1.2 Shear Walls

96.7.2 Seismic Force Resisting System

96.7.32 Frame Members Not Proportioned To Resist Forces Induced by Earthquake Motions

96.7.43 Plain Concrete

Exceptions 1 through 3

Appendix to Chapter 9 9A6A., Reinforced Concrete Structural Systems Composed from Interconnected Precast Elements

Preface

9A6A.1 General

9A6A.1.1 Scope

9A6A.1.2 Reference Document

Ref. 6A-1

9A6A.2 General Principles

9A6A.3 Lateral Force Resisting Structural Framing Systems

9A6A.3.1

9A6A.3.2

9A6A.3.3

Table 9A6A.3.3 Restrictions on  $R$  and  $C_d$

9A6A.3.4

9A6A.4 Connection Performance Requirements

9A6A.4.1

9A6A.4.2

9A6A.4.3

9A6A.4.4

9A6A.4.5

9A6A.5 Connection Design Requirements

9A6A.5.1

9A6A.5.2

9A6A.5.3

9A6A.5.4

Chapter 10 ~~Chapter 7~~ COMPOSITE STEEL AND CONCRETE STRUCTURE DESIGN REQUIREMENTS

7.1 Scope

10.1 ~~7.2~~ Reference Documents

Ref. ~~107-1~~ through ~~7-5~~ 10-4

10.2 Requirements

~~7.3~~ Definitions and Symbols



- 7.3.1 Definitions
- 7.3.2 Symbols
- 7.4 Composite Systems
  - 7.4.1 Composite Partially Restrained Frames (C-PRF)
    - 7.4.1.1 Limitations
      - 7.4.1.1.1
      - 7.4.1.1.2
    - 7.4.1.2 Columns
    - 7.4.1.2 Composite Beams
    - 7.4.1.4 Partially Restrained Connection
  - 7.4.2 Composite Ordinary Moment Frames (C-OMF)
    - 7.4.2.1 Columns
    - 7.4.2.2 Beams
    - 7.4.2.3 Moment Connections
  - 7.4.34 Composite Special Moment Frames (C-SMF)
    - 7.4.34.1 Columns
    - 7.4.34.2 Beams
    - 7.4.34.3 Moment Connections
    - 7.4.34.4 Column-Beam Moment Ratio
  - 7.4.46 Composite Concentrically Braced Frames (C-CBF)
    - 7.4.4.1 Limitations
    - 7.4.4.2 Columns
    - 7.4.4.3 Beams
    - 7.4.4.4 Braces
    - 7.4.4.5 Bracing Connections
  - 7.4.57 Composite Eccentrically Braced Frames (C-EBF)
    - 7.4.5.1 Limitations
    - 7.4.5.2 Columns
    - 7.4.5.3 Link Beams
    - 7.4.5.4 Braces
    - 7.4.5.5 Connections
  - 7.4.6 RC Shear Walls Composite with Steel Elements
    - 7.4.6.1 Limitations
    - 7.4.6.2 Boundary Elements
      - 7.4.6.2.1 Steel Shapes
      - 7.4.6.2.2 Encased Steel Shapes
      - 7.4.6.2.3 Shear Connectors
    - 7.4.6.3 Coupling Beams
      - 7.4.6.3.1
      - 7.4.6.3.2
      - 7.4.6.3.3
  - 7.4.7 Composite Shear Walls
    - 7.4.7.1 Wall Element
      - 7.4.7.1.1 Calculation of Shear Strength
        - Eq. 7.4.7.1.1

- 7.4.7.1.2 Concrete Stiffening
- 7.4.7.1.3 Shear Transfer
- 7.4.7.2 Boundary Members
- 7.4.7.3 Openings in Composite Walls
- 7.5 Composite Members
  - 7.5.1 Composite Slabs
    - 7.5.1.1 Shear Fasteners
    - 7.5.1.2 Shear Strength
  - 7.5.2 Composite Beams
    - 7.5.2.1 Additional Requirements for Special Moment Frames
    - 7.5.2.2 Plastic Stress Distribution
      - Eq. 7.5.2.2
    - 7.5.2.3 Width-Thickness Ratios
  - 7.5.3 Encased Composite Columns
    - 7.5.3.1 Shear Strength
    - 7.5.3.2 Shear Connectors
    - 7.5.3.3 Transverse Reinforcement
    - 7.5.3.4 Longitudinal Reinforcement
    - 7.5.3.5 Steel Core
    - 7.5.3.6 Additional Requirements in Seismic Performance Category C
    - 7.5.3.7 Additional Requirements in Seismic Performance Categories D and E
      - 7.5.3.7.1 Columns
        - 7.5.3.7.2 Transverse Reinforcement
          - Eq. 7.5.3.7.2
        - 7.5.3.7.3 Longitudinal Bars
        - 7.5.3.7.4 Steel Core
        - 7.5.3.7.5 Columns Supporting Discontinuous Walls
        - 7.5.3.7.6 Columns Supported by Walls or Footings
      - 7.5.3.8 Additional Requirements in Special Moment Frames
        - 7.5.3.8.1 Strong Column/Weak Beam
        - 7.5.3.8.2 Shear Strength
        - 7.5.3.8.3 Transverse Reinforcement
  - 7.5.4 Filled Composite Columns
    - 7.5.4.1 Shear Strength
    - 7.5.4.2 Additional Requirements in Seismic Performance Categories D and E
      - 7.5.4.2.1 Columns
        - 7.5.4.2.2 Steel Tube
    - 7.5.4.3 Additional Requirements for Special Moment Frames
      - 7.5.4.3.1 Shear Strength
      - 7.5.4.3.2 Strong Column/Weak Beam
      - 7.5.4.3.3 Structural Steel Pipe and Tubing
- 7.6 Composite Connections
  - 7.6.1 General Requirements
  - 7.6.2 Strength Design Criteria
    - 7.6.2.1 Force Transfer Between Structural Steel and Concrete

- ~~7.6.2.2~~ Structural Steel Elements
- ~~7.6.2.3~~ Shear Friction and Bearing Stresses in Concrete
- ~~7.6.2.4~~ Panel Zones
- ~~7.6.2.5~~ Reinforcing Bar Detailing Provisions
- ~~7.6.2.5.1~~ Slab Reinforcement in Connection Region
- ~~7.6.2.5.2~~ Transverse Reinforcement in Columns or Walls near Joint
- ~~7.6.2.5.3~~ Longitudinal Reinforcement in Columns near Joints

~~Chapter 11~~ ~~Chapter 8~~ MASONRY STRUCTURE DESIGN REQUIREMENTS

- ~~118.1~~ General
  - ~~118.1.1~~ Scope
  - ~~118.1.2~~ Reference Documents
    - ~~Design and Construction Standards~~
      - Ref. ~~118-1~~ and ~~118-2~~
    - ~~Materials Standards~~
      - Ref. ~~8-3~~ through ~~8-36~~
  - ~~118.1.3~~ Definitions
  - ~~118.1.4~~ Notations
- ~~118.2~~ Construction Requirements
  - ~~118.2.1~~ General
  - ~~118.2.2~~ Quality Assurance
- ~~118.3~~ General Design Requirements
  - ~~118.3.1~~ Scope
  - ~~118.3.2~~ Empirical Masonry Design
  - ~~118.3.3~~ Plain (Unreinforced) Masonry Design
    - ~~118.3.3.1~~
    - ~~118.3.3.2~~
    - ~~118.3.3.3~~
  - ~~118.3.4~~ Reinforced Masonry Design
  - ~~118.3.5~~ Seismic Performance Design Category A
  - ~~118.3.6~~ Seismic Performance Design Category B
  - ~~118.3.7~~ Seismic Performance Design Category C
    - ~~8.3.7.6~~ ~~11.3.7.1~~ Material Requirements
    - ~~11.3.7.2~~ Masonry Shear Walls
    - ~~118.3.7.1~~
    - ~~118.3.7.23~~ Minimum Wall Reinforcement
    - ~~11.3.7.4~~ Stack Bond Construction
    - ~~118.3.7.45~~ Multiple Wythe Walls Not Acting Compositely
    - ~~118.3.7.56~~ Walls Separated from the Basic Structural System
    - ~~11.3.7.7~~ Connections to Masonry Columns
  - ~~118.3.8~~ Seismic Performance Design Category D
    - ~~118.3.8.1~~ Material Requirements
    - ~~11.3.8.2~~ Masonry Shear Walls
    - ~~118.3.8.23~~ Minimum Wall Reinforcement

- 118.3.8.34 Stack Bond Construction
- 8.3.8.4
- 118.3.8.5 Minimum Dimensions Minimum Wall Thickness
- 11.3.8.6 Minimum Column Reinforcement
- ~~118.3.8.5.1~~
- 118.3.8.5.27 Minimum Column Dimension
- 8.3.8.6 — Shear Walls
- 8.3.8.6.1
- 8.3.8.6.2
- 8.3.8.7
- 11.3.8.8 Separation Joints
- 118.3.9 Seismic Performance Design Category E and F
- 118.3.9.1 Material Construction Requirements
- 11.3.9.2 Masonry Shear Walls
- 8.3.9.2 Reinforced Hollow Unit Masonry
- 11.3.9.38.3.9.3 Stacked Bond Construction
- 11.3.9.3.1 8.3.9.3.1
- 11.3.9.3.2 8.3.9.3.2
- 118.3.10 Properties of Materials
- 118.3.10.1 Steel Reinforcement Modulus of Elasticity
- 118.3.10.2 Masonry Modulus of Elasticity
  - Eq. 118.3.10.2
- 118.3.10.3
- 118.3.10.4 Masonry Compressive Strength
  - 118.3.10.4.1
  - 118.3.10.4.2
- 118.3.10.5 Modulus of Rupture
  - 118.3.10.5.1 Out-of-Plane Bending Running Bond Masonry
    - Table 118.3.10.5.1, Modulus of Rupture for Masonry Laid in Running Bond ( $f_r$ )
  - 118.3.10.5.2 Stack Bond Masonry In-Plane Bending
- 118.3.10.6 Reinforcement Strength
- 118.3.11 Section Properties
  - 118.3.11.1
  - 118.3.11.2
- 118.3.12 Plate, Headed, and Bent Bar Anchor Bolts
  - 118.3.12.1
    - Eq. 118.3.12.1-1
    - Eq. 118.3.12.1-2
  - 118.3.12.1.1
    - Eq. 118.3.12.1.1-1
    - Eq. 118.3.12.1.1-2
  - 118.3.12.1.2
  - 8.3.12.1.3
  - ~~118.3.12.1.4~~11.1.3
  - 11.3.12.2

Eq. 11.3.12.2-1  
Eq. 11.3.12.2-2  
Eq. 11.3.12.2-3  
118.3.12.2.1  
Eq. 118.3.12.2.1-1  
Eq. 118.3.12.2.1-2  
11.2.12.2.2  
11.3.12.2.3  
118.3.12.3  
Eq. 118.3.12.3.1  
Eq. 11.3.12.3-2  
11.3.12.3.1  
11.3.12.4  
Eq. 11.3.12.4  
118.4 Details of Reinforcement  
118.4.1 General  
118.4.1.1  
118.4.1.2  
118.4.2 Size of Reinforcement  
118.4.2.1  
8.4.2.2  
118.4.2.3  
118.4.3 Placement Limits for Reinforcement  
118.4.3.1  
118.4.3.2  
118.4.3.3  
118.4.3.4  
8.4.3.5  
118.4.4 Cover for Reinforcement  
118.4.4.1  
11.4.4.2  
118.4.4.3  
118.4.4.34  
118.4.5 Development of Reinforcement  
118.4.5.1 General  
118.4.5.2 Embedment of Reinforcing Bars and Wires in Tension  
Eq. 118.4.5.2  
118.4.5.3 Standard Hooks  
118.4.5.3.1  
118.4.5.3.1.1  
118.4.5.3.1.2  
11.4.5.3.1.3  
118.4.5.3.1.34  
11.4.5.3.2  
11.4.5.3.3

118.4.5.4 Minimum Bend Diameter for Reinforcing Bars

118.4.5.4.1

Table 118.4.5.4.1, Minimum Diameters of Bend

8.4.5.4.2

— Eq. 8.4.5.4.2

8.4.5.4.3

118.4.5.5 Development of Shear Reinforcement

8.4.5.5.1 Bar and Wire Reinforcement

118.4.5.5.1.1

118.4.5.5.1.2

11.4.5.5.3

8.4.5.5.2 Wire Fabric

8.4.5.5.2.1

8.4.5.5.2.2

118.4.5.6 Splices of Reinforcement

118.4.5.6.1 Lap Splices

118.4.5.6.1.1

118.4.5.6.1.2

8.4.5.6.1.3

118.4.5.6.2 Welded Splices

118.4.5.6.3 Mechanical Connections

118.4.5.6.4 End Bearing Splices

118.4.5.6.4.1

118.4.5.6.4.2

118.4.5.6.4.3

118.5 Strength and Deformation Requirements

118.5.1 General

118.5.2 Required Strength

118.5.3 Design Strength

Table 118.5.3, Strength Reduction Factor

118.5.4 Deformation Requirements

118.5.4.1

118.5.4.1.1

118.5.4.2

118.5.4.3

Eq. 118.5.4.3

118.5.4.4

118.6 Flexure and Axial Loads

118.6.1 Scope

118.6.2 Design Requirements of Reinforced Masonry Members

118.6.2.1

118.6.2.2

118.6.2.3

118.6.3 Design of Plain (Unreinforced) Masonry Members

118.6.3.1

- 118.6.3.2
- 118.6.3.3
- 118.6.3.4
- 118.6.3.5
  - Eq. 118.6.3.5-1
  - Eq. 118.6.3.5-2
- 118.7 Shear
  - 118.7.1 Scope
  - 118.7.2 Shear Strength
    - 118.7.2.1
      - Eq. 118.7.2.1
    - 118.7.2.2
  - 118.7.3 Design of Reinforced Masonry Members
    - 118.7.3.1
      - Eq. 118.7.3.1-1
      - Eq. 118.7.3.1-2
      - Eq. 118.7.3.1-3
    - 118.7.3.2
      - Eq. 118.7.3.2-1
      - Eq. 8.7.3.2-2
    - 118.7.3.3
      - Eq. 118.7.3.3
  - 118.7.4 Design of Plain (Unreinforced) Masonry Members
    - 118.7.4.1
  - 118.8 Special Requirements for Beams
    - 118.8.1
    - 118.8.2
    - 118.8.3
    - 118.8.4 Deep Flexural Members
      - 118.8.4.1
      - 118.8.4.2
      - 118.8.4.3
  - 118.9 Special Requirements for Columns
    - 118.9.1
    - 118.9.2
    - 118.9.3
  - 118.10 Special Requirements for Walls
    - 118.10.1
  - 118.11 Special Requirements for Shear Walls
    - 11.11.1 Ordinary Plain Masonry Shear Walls
    - 11.11.2 Detailed Plain Masonry Shear Walls
    - 11.11.3 Ordinary Reinforced Masonry Shear Walls
    - 11.11.4 Intermediate Reinforced Masonry Shear Walls
    - 11.11.5 Special Reinforced Masonry Shear Walls
      - 11.11.5.1 Vertical Reinforcement

- 11.11.5.2 Horizontal Reinforcement
- 11.11.5.3 Shear Keys
- 8.11.1 Reinforcement
- 8.11.2 Confinement of Compressive Stress Zone
- 8.11.2.1
- 8.11.2.2
- 8.11.2.3
- 118.11.36 Flanged Shear Walls
- 118.11.36.1
- 8.11.3.2
- 118.11.3.36.2
- 118.11.3.46.3
- 118.11.47 Coupled Shear Walls
- 118.11.47.1 Design of Coupled Shear Walls
- 118.11.47.2 Shear Strength of Coupling Beams  
Eq. 118.11.47.2
- 118.12 Wall Frames Special Moment Frames of Masonry
- 8.12.1
- 118.12.21 Calculation of Required Stress
- 118.12.32 Flexural Yielding
- 118.12.43 Reinforcement
- 118.12.43.1
- 118.12.43.2
- 118.12.43.3
- 118.12.43.4
- 118.12.54 Wall Frames Beams
- 118.12.54.1
- 8.12.5.2
- 118.12.5.34.2
- 118.12.5.44.3
- 118.12.5.54.4
- 11.12.4.5
- 118.12.5.64.6 Longitudinal Reinforcement
- 118.12.5.6.14.6.1
- 118.12.5.6.24.6.2
- 118.12.5.6.34.6.3
- 11.12.4.6.4
- 118.12.5.74.7 Transverse Reinforcement
- 118.12.5.7.14.7.1
- 118.12.5.7.24.7.2
- 118.12.5.7.34.7.3
- 118.12.5.7.44.7.4
- 11.12.4.7.5
- 118.12.65 Wall Frame Columns
- 118.12.6.15.1



118.12.6.25.2

118.12.6.35.3

11.12.5.4

118.12.6.45.5 Longitudinal Reinforcement

118.12.6.4.15.5.1

118.12.6.4.25.5.2

11.12.5.5.3

11.12.5.5.4

8.12.6.4.3

118.12.6.55.6 Transverse Reinforcement

118.12.6.5.15.6.1

118.12.6.5.25.6.2

118.12.6.5.35.6.3

118.12.76 Wall Frame Beam-Column Intersection

118.12.7.16.1

Eq. 118.12.76.1-1

Eq. 118.12.76.1-2

118.12.7.26.2

Eq. 118.12.7.26.2

11.13 Glass-Unit Masonry and Masonry Veneer

11.13.1 Design Lateral Force Displacements

11.13.2 Glass-Unit Masonry Design

11.13.2.1

11.13.3 Masonry Veneer Design

11.13.3.1

11.13.3.2

Appendix to Chapter 11 ~~Chapter 8~~, ALTERNATIVE MASONRY STRUCTURE DESIGN PROVISIONS

11A8A.1 General

11A8A.1.1 Scope

11A8A.1.2 Reference Documents

Ref. 8A-1

11A8A.1.2.1 Modifications to Chapter 10 ~~Appendix A~~ of Reference 118A-1

11A.1.2.1.1

11A.1.2.1.2

11A.1.2.1.3

11A.2 Response Modification Coefficients

8A.1.2.1.1

— Table 8A.1.2.1.1

8A.1.2.1.2

8A.1.2.1.3

8A.1.2.1.4

8A.1.2.1.5

8A.1.2.1.6

8A.1.2.1.7

- ~~8A.2 Strength of Members and Connections~~
- ~~8A.3 Response Modification Coefficients~~
- ~~8A.4 Seismic Performance Category A~~
- ~~8A.5 Seismic Performance Category B~~
- ~~8A.6 Seismic Performance Category C~~
  - ~~8A.6.1 Construction Requirements~~
    - ~~8A.6.1.1 Multiple Wythe Walls Not Acting Compositely~~
    - ~~8A.6.1.2 Screen Walls~~
      - ~~8A.6.1.2.1~~
      - ~~8A.6.1.2.2~~
  - ~~8A.6.2 Material Requirements~~
- ~~8A.7 Seismic Performance Category D~~
  - ~~8A.7.1 Construction Requirements for Masonry Laid in Other than Running Bond~~
  - ~~8A.7.2 Shear Wall Requirements~~
    - ~~8A.7.2.1~~
    - ~~8A.7.2.2~~
- ~~8A.8 Seismic Performance Category E~~
  - ~~8A.8.1 Construction Requirements~~
    - ~~8A.8.1.1 Reinforced Hollow Unit Masonry~~
    - ~~8A.8.1.2 Stack Bond Construction~~
      - ~~8A.8.1.2.1~~
      - ~~8A.8.1.2.2~~

Chapter 12 ~~Chapter 9~~ WOOD STRUCTURES DESIGN REQUIREMENTS

- 12.1 General
    - 12.1.1 Scope
      - ~~12.1.2.1~~ Reference Documents
        - ~~Ref. 9-1 through 9-14~~
      - 12.1.2.1 Engineered Wood Construction
        - Ref. 12-1 through 12-4
      - 12.1.2.2 Conventional Light Frame Construction
        - Ref. 12-5 through 12-6
      - 12.1.2.3 Material Standards
        - Ref. 12-8 through 12-14
    - 12.1.3 Notations
  - 12.2 Design Methods
    - 12.2.1 Engineered Wood Design
    - 12.2.2 Conventional Light-Frame Construction
      - 12.2.2.1
  - ~~12.3.8~~ Engineered Wood Construction
    - 12.3.1 General
    - ~~12.3.2.8.1~~ Framing Requirements
    - 12.3.3.8.2 Diaphragm and Shear Wall Requirements Deformation Compatibility Requirements
  - ~~9.8.2.1~~ Framing
-

~~9.8.2.2 Anchorage and Connections~~

~~9.8.2.3 Torsion~~

~~Exception~~

12.3.4 Design Limitations

12.3.4.1 Wood Members Resisting Horizontal Seismic Forces Contributed by Masonry and Concrete

Exceptions 1 and 2

12.3.4.2 Horizontal Distribution of Shear

Exception

12.3.4.3 Framing and Anchorage Limitations

12.3.4.4 Shear Wall Anchorage

12.4.9 Diaphragms and Shear Walls

12.4.1 Diaphragm and Shear Wall Aspect Ratios

12.4.2 Shear Resistance Based on Principles of Mechanics

12.4.3.9.1 Sheathing Shear Panel Requirements

Exception

12.4.3.19.9.1.1 Structural-Use Shear Panels Sheathing

12.4.3.29.9.1.2 Shear Panels Sheathed with Other Sheet Materials Other Panel Sheathing Materials

12.4.3.39.9.1.3 Single Diagonally Sheathed Lumber Diaphragms and Shear Panels Walls

12.4.3.49.9.1.4 Double Diagonally Sheathed Lumber Diaphragms and Shear Panels Walls

Table ~~12.4.3-1a~~ 9.9.1-1a Allowable Shear in Pounds per Foot (at Working Stress Factored Shear Resistance) for Horizontal Diaphragms with Framing Members of Douglas Fir, Larch, or Southern Pine for Seismic Loadings

Table ~~12.4.3-2a~~ 9.9.1-1b Allowable Working Stress Shear in Pounds per Lineal Foot Factored Shear Resistance for Seismic Forces on Structural-Use Panel Shear Walls with Framing of Douglas Fir, Larch, or Southern Pine

~~12.5.9.10~~ Conventional Light Frame Construction

Exception

~~9.10.1 Braced Walls~~

Table ~~12.5.1-19.10.1-1a~~ Conventional Light-Frame Construction Braced Wall Requirements

Table ~~12.5.2-19.10.1-1b~~ Conventional Light-Frame Construction Braced Wall Requirements in Minimum Length of Wall Bracing per Each 25 Lineal Feet of Braced Wall Line

~~12.5.1.19.10.1.1~~ Braced Wall Spacing Scope

Exceptions 1 and 2

12.5.1.1 Irregular Structures

12.5.1.1.1

12.5.1.1.2

Exception

12.5.1.1.3

Exception

12.5.1.1.4

12.5.1.1.5

12.5.1.1.6

12.5.1.1.7 Stepped Foundation

12.5.2 Braced Walls

- 12.5.2.1 Spacing Between Braced Wall Lines
- 12.5.2.2 Braced Wall Line Sheathing Requirements
- 12.5.2.3 Attachment
  - 12.5.2.3.1
  - 12.5.2.3.2
  - 12.5.2.3.3
- ~~9.10.1.2 Braced Wall Sheathing Requirements~~
- 12.5.3 Detailing Requirements
- ~~9.10.2 Wall Framing and Connections~~
  - ~~12.5.3.19.10.2.1 Wall Anchorage~~
  - ~~12.5.3.29.10.2.2 Top Plates~~
  - ~~12.5.3.39.10.2.3 Bottom Plates~~
  - ~~12.5.3.49.10.2.4 Roof and Floor to Braced Wall Panel Connection~~
- 12.5.3.5 Foundations Supporting Braced Wall Panels
- 12.5.3.6 Stepped Footings
- 12.5.3.7 Detailing for Openings in Diaphragms
- ~~9.2 Strength of Members and Connections~~
- 12.69.3 Seismic Performance Design Category A
- 12.79.4 Seismic Performance Design Category B, C, and D
  - ~~12.7.19.4.1 Construction Limitations; Conventional Light-Frame Construction~~
- 12.7.2 Engineered Construction
- ~~9.5 Seismic Performance Design Category C~~
  - ~~9.5.1 Material Limitations, Structural-Use Panel Sheathing~~
  - ~~9.5.2 Detailing Requirements~~
    - ~~9.5.2.1 Anchorage of Concrete or Masonry Walls~~
    - ~~9.5.2.2 Lag Screws~~
- ~~9.6 Seismic Performance Design Category D~~
  - ~~9.6.1 Framing Systems~~
    - ~~9.6.1.1 Diaphragms~~
    - ~~9.6.1.2 Anchorage of Concrete and Masonry Walls~~
- 12.89.7 Seismic Performance Design Category E and F
- ~~9.7.1 Framing Systems~~
- ~~12.8.19.7.2 Diaphragm and Shear Wall Limitations~~
  - 12.8.1.1
    - Exception
  - 12.8.1.2

## Chapter 13 SEISMICALLY ISOLATED STRUCTURE DESIGN REQUIREMENTS

- ~~2.6 Provisions for Seismically Isolated Structures~~
  - 132.6.1 General
  - 132.6.2 Criteria Selection
    - 132.6.2.1 Basis for Design
    - 132.6.2.2 Stability of the Isolation System
    - 132.6.2.3 Seismic Hazard Exposure Group

- 132-6.2.4 Configuration Requirements
- 132-6.2.5 Selection of Lateral Response Procedure
  - 132-6.2.5.1 General
  - 132-6.2.5.2 Equivalent Lateral Force Procedure
  - 132-6.2.5.3 Dynamic Analysis
    - 132-6.2.5.3.1 Response-Spectrum Analysis
    - 132-6.2.5.3.2 Time-History Analysis
    - 132-6.2.5.3.3 Site-Specific Design Spectra
- 132-6.3 Equivalent Lateral Force Procedure
  - 132-6.3.1 General
  - 132-6.3.2 Deformation Characteristics of the Isolation System
  - 132-6.3.3 Minimum Lateral Displacements
    - 132-6.3.3.1 Design Displacements
      - Eq. 132-6.3.3.1
      - ~~Table 2.6.3.3.1a~~ Near-Field Site Response Coefficient  $N_s$
      - Table 132-6.3.3.1b Damping Coefficient  $B_I$
    - 132-6.3.3.2 ~~Effective Isolated-Building~~ Period
      - Eq. 132-6.3.3.2
      - 13.3.3.3 Maximum Displacement
      - 13.3.3.4 Effective Period at Maximum Displacement
      - 132-6.3.3.3.5 Total Design Displacement
        - Eq. 132-6.3.3.3.5-1 and 13.3.3.5-2
    - ~~2.6.3.3.4~~ Total Maximum Displacement
      - ~~Eq. 2.6.3.3.4~~
      - ~~Table 2.6.3.3.4~~ Maximum Capable Earthquake Displacement Coefficient  $M_{\gamma}$
  - 132-6.3.4 Minimum Lateral Forces
    - 132-6.3.4.1 Isolation System and Structural Elements at or Below the Isolation System
      - Eq. 132-6.3.4.1
    - 132-6.3.4.2 Structural Elements Above the Isolation System
      - Eq. 132-6.3.4.2
    - 132-6.3.4.3 Limits on  $V_s$
  - 132-6.3.5 Vertical Distribution of Force
    - Eq. 132-6.3.5
  - 132-6.3.6 Drift Limits
- 132-6.4 Dynamic Lateral Response Procedure
  - 132-6.4.1 General
  - 132-6.4.2 Isolation System and Structural Elements Below the Isolation System
    - Eq. 132-6.4.2
  - 132-6.4.3 Structural Elements Above the Isolation System
    - Exception
    - Exception
  - 132-6.4.4 Ground Motion
    - 132-6.4.4.1 Design Spectra
      - Exception
      - ~~Table 2.6.4.4.1~~ Construction of Response Spectra

- Eq. 132-6.4.4.1-1
- Eq. 132-6.4.4.1-2
- Eq. 132-6.4.4.1-3
- 132-6.4.4.2 Time Histories
- 132-6.4.5 Mathematical Model
  - 132-6.4.5.1 General
  - 132-6.4.5.2 Isolation System
  - 132-6.4.5.3 Isolated Building
    - 132-6.4.5.3.1 Displacement
    - 132-6.4.5.3.2 Forces and Displacements in Key Elements
- 132-6.4.6 Description of Analysis Procedures
  - 132-6.4.6.1 General
  - 132-6.4.6.2 Input Earthquake
  - 132-6.4.6.3 Response-Spectrum Analysis
  - 132-6.4.6.4 Time-History Analysis
  - 132-6.4.7 Design Lateral Force
    - 132-6.4.7.1 Isolation System and Structural Elements at or Below the Isolation System
    - 132-6.4.7.2 Structural Elements Above the Isolation System
    - 132-6.4.7.3 Scaling of Results
    - 132-6.4.7.4 Drift Limits
- 132-6.5 Lateral Load on Elements of Buildings and Nonstructural Components Supported by Buildings
  - 132-6.5.1 General
  - 132-6.5.2 Forces and Displacements
    - 132-6.5.2.1 Components at or Above the Isolation Interface
      - Exception
    - 132-6.5.2.2 Components Crossing the Isolation Interface
    - 132-6.5.2.3 Components Below the Isolation Interface
- 132-6.6 Detailed System Requirements
  - 132-6.6.1 General
  - 132-6.6.2 Isolation System
    - 132-6.6.2.1 Environmental Conditions
    - 132-6.6.2.2 Wind Forces
    - 132-6.6.2.3 Fire Resistance
    - 132-6.6.2.4 Lateral-Restoring Force
      - Exception
    - 132-6.6.2.5 Displacement Restraint
    - 132-6.6.2.6 Vertical-Load Stability
    - 132-6.6.2.7 Overturning
    - 132-6.6.2.8 Inspection and Replacement
    - 132-6.6.2.9 Quality Control
  - 132-6.6.3 Structural System
    - 132-6.6.3.1 Horizontal Distribution of Force
    - 132-6.6.3.2 Building Separations
    - 132-6.6.3.3 Nonbuilding Structures

- 132.6.7 Foundations
- 132.6.8 Design and Construction Review
  - 132.6.8.1 General
  - 132.6.8.2 Isolation System
- 132.6.9 Required Tests of the Isolation System
  - 132.6.9.1 General
  - 132.6.9.2 Prototype Tests
    - 132.6.9.2.1 General
    - 132.6.9.2.2 Record
    - 132.6.9.2.3 Sequence and Cycles
    - 132.6.9.2.4 Units Dependent on Loading Rates
    - 132.6.9.2.5 Units Dependent on Bilateral Load
    - 132.6.9.2.6 ~~Maximum and Minimum Downward~~-Vertical Load
    - 132.6.9.2.7 Sacrificial-Wind-Restraint Systems
    - 132.6.9.2.8 Testing Similar Units
  - 132.6.9.3 Determination of Force-Deflection Characteristics
    - Eq. 132.6.9.3
  - 132.6.9.4 ~~Test Specimen System~~ Adequacy
  - 132.6.9.5 Design Properties of the Isolation System
    - 13.9.5.1 ~~Maximum and Minimum Effectiveness Stiffness~~
    - 13.9.5.2 ~~Effective Damping~~
      - 2.6.9.5.1 ~~Effective Stiffness~~
      - 2.6.9.5.2 ~~Effective Damping~~
        - Eq. 2.6.9.5.2

Appendix to Chapter 2 13, Passive Energy Dissipation Systems

Preface

- 2A.1 General
- 2A.2 Structural Framing Systems
- 2A.3 Analysis Procedures
  - Exception
  - Table 2A.3 Reduction Factors for Increased Building Damping
    - 2A.3.1 Linear Viscous Devices
    - 2A.3.2 Other Energy Dissipation Devices
      - 2A.3.2.1 Equivalent Viscously Damped System
        - Eq. 2A.3.2.1
      - 2A.3.2.2 Nonlinear Dynamic Response Verification
        - 2A.3.2.2.1 Ground Motion Records
        - 2A.3.2.2.2 Mathematical Model
          - Exception
- 2A.4 Testing
  - 2A.4.1 Prototype Tests
    - Exception
  - 2A.4.2 Force-Deformation Characteristics
  - 2A.4.3 System Adequacy

- Item a
- Exception
- Item b
- Exception
- Item c
- Exception

## Chapter 14 NONBUILDING STRUCTURES

### 2.7 Provisions for Nonbuilding Structures

#### 14.2.7.1 General

##### 14.2.7.1.1 Scope

#### 14.1.2 Nonbuilding Structures Supported by Other Structures

##### 2.7.1.2

#### 14.1.3 Architectural, Mechanical, and Electrical Components

##### 14.1.4.2.7.1.3 Loads

##### 14.1.5.2.7.1.4 Fundamental Period

##### 14.1.6.2.7.1.5 Drift Limitations

##### 2.7.1.6

##### 2.7.2

##### Exception

#### 14.1.7.2.7.3 Material Requirements

##### Eq. 2.7.3

##### 2.7.4

##### 2.7.5

#### Table 2.7.5 R Factors for Nonbuilding Structures

### 14.2 Structural Design Requirements

#### 14.2.1 Design Basis

#### 14.2.2 Rigid Nonbuilding Structures

#### 14.2.3 Deflection Limits and Structure Separation

### 14.3 Nonbuilding Structures Similar to Buildings

#### 14.3.1 General

#### 14.3.2 Pipe Racks

#### 14.3.3 Steel Storage Racks

#### 14.3.4 Electrical Power Generating Facilities

#### 14.3.5 Structural Towers for Tanks and Vessels

#### 14.3.6 Piers and Wharves

### 14.4 Nonbuilding Structures Not Similar to Buildings

#### 14.4.1 General

#### 14.4.2 Earth Retaining Structures

#### 14.4.3 Tanks and Vessels

#### 14.4.4 Electrical Transmission, Substation, and Distribution Structures

#### 14.4.5 Telecommunication Towers

#### 14.4.6 Stacks and Chimneys



14.4.7 Amusement Structures

14.4.8 Special Hydraulic Structures

14.4.9 Buried Structures

14.4.10 Inverted Pendulums

Appendix to Chapter 14

Preface

A14.1 References and Standards

A14.1.1 Standards

A14.1.2 Industry Standards

A14.1.3 General References

A14.2 Industry Design Standards and Recommended Practice

A14.3 Tanks and Vessels

A14.3.1 General

A14.3.2 Ground-Suported Storage Tanks for Liquids

A14.3.3 Ground-Supported Storage Tanks for Granular Materials

A14.3.4 Elevated Tanks for Liquids and Granular Materials

A14.3.5 Boiler and Pressure Vessels

A14.3.6 Liquid and Gas Spheres

A14.3.7 Refrigerated Gas Liquid Storage Tanks and Vessels

A14.3.8 Horizontal, Saddle Supported Vessels for Liquid or Vapor Storage

A14.3.9 Impoundment Dikes and Walls

A14.4 Electrical Transmission, Substation, and Distribution Structures

A14.4.1 General

A14.4.2 Design Basis

A14.5 Telecommunication Towers

A14.5.1 General

A14.5.2 Design Basis

*Remainder of Chapter 14 and Appendix to Chapter 14 are new*

**GLOSSARY** *moved to 1997 Sec. 2.1*

**NOTATIONS** *moved to 1997 Sec. 2.2*

## Appendix B

### BSSC 1997 UPDATE PROGRAM PARTICIPANTS

#### 1995 BOARD OF DIRECTION

<b>Chairman</b>	James E. Beavers, MS Technology, Inc., Oak Ridge, Tennessee
<b>Vice Chairman</b>	Allan R. Porush, Dames and Moore, Los Angeles, California
<b>Secretary</b>	Joseph "Jim" Messersmith, Portland Cement Association, Rockville, Virginia;
<b>Ex-Officio</b>	Gerald H. Jones, Kansas City, Missouri
<b>Members</b>	Mark B. Hogan, National Concrete Masonry Association, Herndon, Virginia; Nestor Iwankiw, American Institute of Steel Construction, Chicago, Illinois
	Les Murphy, AFL-CIO Building and Construction Trades Department, Washington, D.C.
	Clifford J. Ousley, Bethlehem Steel Corporation, Bethlehem, Pennsylvania (representing the American Iron and Steel Institute)
	F. Robert Preece, Preece/Goudie and Associates, San Francisco, California (representing the Earthquake Engineering Research Institute)
	Jack Prosek, Turner Construction Company, San Francisco, California (representing the Associated General Contractors of America)
	William W. Stewart, Stewart-Schaberg Architects, Clayton, Missouri (representing the American Institute of Architects)
	John C. Theiss, Theiss Engineers, Inc., St. Louis, Missouri (representing the American Society of Civil Engineers)
	David P. Tyree, American Forest and Paper Association, Georgetown, California
	David Wismer, Department of Licenses and Inspections, Philadelphia, Pennsylvania (representing the Building Officials and Code Administrators International)
	Richard Wright, National Institute of Standards and Technology, Gaithersburg, Maryland (representing the Interagency Committee for Seismic Safety in Construction)

## 1996 BOARD OF DIRECTION

### **Chairman**

Eugene Zeller, Director of Planning and Building, Department of Planning and Building, Long Beach, California

### **Vice Chairman**

Richard Wright, Director, Building and Fire Research Laboratory, National Institute of Standards and Technology, Gaithersburg, Maryland (representing the Interagency Committee for Seismic Safety in Construction)

### **Secretary**

Joseph J. Messersmith, Coordinating Manager, Regional Code Services, Portland Cement Association, Rockville, Virginia

### **Members**

James E. Beavers, Ex officio, MS Technology, Inc., Oak Ridge, Tennessee

Mark B. Hogan, Vice President of Engineering, National Concrete Masonry Association, Herndon, Virginia

Nestor Iwankiw, Vice President, Technology and Research, American Institute of Steel Construction, Chicago, Illinois

Gerald H. Jones, Kansas City, Missouri (representing the National Institute of Building Sciences)

Joseph Nicoletti, Senior Consultant, URS/John A. Blume and Associates, San Francisco, California (representing the Earthquake Engineering Research Institute)

Allan R. Porush, Structural Engineer, Dames and Moore, Los Angeles, California (representing the Structural Engineers Association of California)

Jack Prosek, Project Manager, Turner Construction Company, Palo Alto, California (representing the Associated General Contractors of America)

William W. Stewart, Stewart Schaberg/Architects, Clayton, Missouri (representing the American Institute of Architects)

John C. Theiss, Vice President, EQE - Theiss, St. Louis, Missouri (representing the American Society of Civil Engineers)

Charles H. Thornton, Chairman, The LZA Group, Thornton-Tomasetti Engineers, New York, New York (representing the Applied Technology Council)

David P. Tyree, Regional Manager, American Forest and Paper Association, Colorado Springs, Colorado

David Wismer, Director of Planning and Code Development, Department of Licenses and Inspections, Philadelphia, Pennsylvania (representing Building Officials and Code Administrators International)

## 1997 BOARD OF DIRECTION

### **Chairman**

Eugene Zeller, City of Long Beach, California

### **Vice Chairman**

William W. Stewart, Stewart-Scholberg Architects, Clayton, Missouri (representing the American Institute of Architects)

### **Secretary**

Mark B. Hogan, National Concrete Masonry Association, Herndon, Virginia

### **Ex-Officio**

James E. Beavers, Beavers and Associates, Oak Ridge, Tennessee

### **Members**

Eugene Cole, Carmichael, California (representing the Structural Engineers Association of California)

S. K. Ghosh, Portland Cement Association, Skokie, Illinois

Nestor Iwankiw, American Institute of Steel Construction, Chicago, Illinois

Gerald H. Jones, Kansas City, Missouri (representing the National Institute of Building Sciences)

Joseph Nicoletti, URS/John A. Blume and Associates, San Francisco, California (representing the Earthquake Engineering Research Institute)

Jack Prosek, Turner Construction Company, San Francisco, California (representing the Associated General Contractors of America)

W. Lee Shoemaker, Metal Building Manufacturers Association, Cleveland, Ohio

John C. Theiss, Theiss Engineers, Inc., St. Louis, Missouri (representing the American Society of Civil Engineers)

Charles Thornton, Thornton-Tomasetti Engineers, New York, New York (representing the Applied Technology Council)

David P. Tyree, American Forest and Paper Association, Georgetown, California

David Wismer, Department of Licenses and Inspections, Philadelphia, Pennsylvania (representing the Building Officials and Code Administrators International)

Richard Wright, National Institute of Standards and Technology, Gaithersburg, Maryland (representing the Interagency Committee for Seismic Safety in Construction)

## **BSSC STAFF**

**Executive Director** — James R. Smith

**Deputy Director** — Thomas Hollenbach

**Program Manager/Technical Writer-Editor** — Claret M. Heider

**Director, Special Projects** — Lee Lawrence Anderson

**Administrative Assistants** — Mary Marshall and Patricia Blasi

## **1997 PROVISIONS UPDATE COMMITTEE**

### **Chair**

William T. Holmes, Vice President, Rutherford and Chekene, San Francisco, California

### **Representing Technical Subcommittee 2, Design Criteria and Analysis**

Ronald O. Hamburger, Vice President, EQE International, San Francisco, California

James R. Harris, J. R. Harris and Company, Denver, Colorado

Fred Turner, Staff Structural Engineer, Seismic Safety Commission (California), Sacramento

### **Representing Technical Subcommittee 3, Foundations and Geotechnical Considerations**

Edward Rinne, Senior Principal, Kleinfelder, Inc., Pleasanton, California

Klaus Jacob, Senior Research Scientist, Lamont-Doherty Geological Observatory of Columbia University, Palisades, New York

### **Representing Technical Subcommittee 4, Concrete Structures**

W. Gene Corley, Vice President, Construction Technology Laboratories, Skokie, Illinois

S. K. Ghosh, Director, Engineering Services, Codes and Standards, Portland Cement Association, Skokie, Illinois (through January 1997)

Joseph J. Messersmith, Coordinating Manager, Regional Code Services, Portland Cement Association, Rockville, Virginia (from February 1997)

Vilas Mujumdar, Chief, Division of State Architect, Office of Regulation Services, Sacramento, California

### **Representing Technical Subcommittee 5, Masonry Structures**

Daniel P. Abrams, Professor, Civil Engineering, University of Illinois, Urbana

J. Gregg Borchelt, Director of Engineering and Research, Brick Institute of America, Reston, Virginia

John Tawresey, KPFF Consulting Engineers, Seattle, Washington

### **Representing Technical Subcommittee 6, Steel Structures**

C. Mark Saunders, Vice President, Rutherford and Chekene, San Francisco, California

Harry W. Martin, American Iron and Steel Institute, Auburn, California

Thomas Sabol, Englekirk and Sabol, Los Angeles, California

### **Representing Technical Subcommittee 7, Wood Structures**

J. Daniel Dolan, Virginia Polytechnic Institute and State University, Blacksburg

Kenneth R. Andreason, Senior Engineer, American Plywood Association, Tacoma, Washington

Kelly Cobeen, GFDS Engineers, San Francisco, California

### **Representing Technical Subcommittee 8, Mechanical/Electrical Systems and Building Equipment and Architectural Elements**

Robert E. Bachman, Department Manager, Civil/Structural Engineering, Fluor Daniel, Inc., Irvine, California

Christopher Arnold, President, Building Systems Development, Palo Alto, California

John D. Gillengerten, Senior Program Manager, John A. Martin and Associates, Inc., Roseville, California

Russell Fleming, Vice President of Engineering, National Fire Sprinkler Association, Patterson, New York

**Representing Technical Subcommittee 9, Quality Assurance**

Charles A. Spitz, Architect-Planner-Code Consultant, West Long Branch, New Jersey

Jim W. Sealy, Jim W. Sealy/Architect/Consultant, Dallas, Texas

**Representing Technical Subcommittee 10, Interface with Codes and Standards**

Susan Dowty, Senior Staff Engineer, International Conference of Building Officials, Whittier, California

John Battles, Southern Building Code Congress, International, Birmingham, Alabama

Karl Deppe, Assistant Deputy Superintendent of Building, City of Los Angeles, California

Scott Humphreys, Building Officials and Code Administrators International, Country Club Hills, Illinois (through March 1997)

**Representing Technical Subcommittee 11, Composite Steel and Concrete Structures**

Gregory Deierlein, Associate Professor, School of Civil and Environmental Engineering, Cornell University, Ithaca, New York

Lawrence Griffis, Senior Vice President, Walter P. Moore and Associates, Inc., Houston, Texas

**Representing Technical Subcommittee 12, Base Isolation and Energy Dissipation**

Charles Kircher, Principal, Charles Kircher and Associates, Consulting Engineers, Mountain View, California

Lawrence Reaveley, Professor and Chair, Civil Engineering Department, University of Utah, Salt Lake City

**Representing Technical Subcommittee 13, Nonbuilding Structures**

Harold Sprague, Structural Engineer, Black and Veatch, Overland Park, Kansas

Robert E. Bachman, ex-officio member of TS13

**At-Large Member**

Robert Elliott, Construction Technology and Codes Specialist, National Association of Home Builders, Washington, D.C. (through June 1997)

Ed Sutton, Construction, Codes & Standards Department, National Association of Home Builders, Washington, D.C. (since June 1997)

**Ex-officio Voting Member**

Loring Wyllie, Degenkolb Engineers, San Francisco, California

**Corresponding Member**

Robert McClure, Building Officials and Code Administrators International, Inc., Country Club Hills, Illinois (beginning April 1997)

## **Technical Subcommittee 2, DESIGN CRITERIA AND ANALYSIS**

### **Chair**

Ronald O. Hamburger, Vice President, EQE International, Inc., San Francisco, California

### **Members**

James R. Harris, President, J. R. Harris and Company, Denver, Colorado

Richard J. Phillips, Vice President/Chief Engineer, Hillman, Biddison and Loevenguth, Los Angeles, California

Fred Turner, Staff Structural Engineer, Seismic Safety Commission (California), Sacramento

Chia-Ming Uang, Associate Professor, Division of Structural Engineering, University of California, San Diego

### **Corresponding Members**

Mohammad Ayub, Office of Construction and Engineering, Department of Labor, Occupational Safety and Health Administration, Washington, D.C.

David R. Bonneville, Degenkolb Engineers, San Francisco, California

John Webster Brown, President, John Webster Brown, Civil and Structural Engineers, Reno, Nevada

James E. Carpenter, Bruce C. Olsen Consulting Engineers, Seattle, Washington

Harish Chander, Civil/Structural Engineer, Office of Nuclear Safety Policy and Standards, Department of Energy, Germantown, Maryland

Anthony Brooks Court, Vice President, Architectural Engineering, Travis, Verdugo, Curry and Associates, San Diego, California

Donald W. Evick, U.S. Postal Service, Columbia, Maryland

S. K. Ghosh, Director, Engineering Services, Codes and Standards, Portland Cement Association, Skokie, Illinois

Walter B. Grossman, Project Engineer, Department of Advanced Technology, Brookhaven National Laboratory, Upton, New York

Husein Hasan, Tennessee Valley Authority, Knoxville, Tennessee

John D. Hooper, Skilling Ward Magnusson Barkshire Inc., Seattle, Washington

Warner Howe, Consulting Structural Engineer, Germantown, Tennessee

Mary Ellen Hynes, Chief, Earthquake Engineering and Seismology Branch, U.S. Army Engineers Waterways Experiment Station, Geotechnical Laboratory, Vicksburg, Mississippi

Helmut Krawinkler, Professor, Department of Civil Engineering, Stanford University, Stanford, California

Uno Kula, Principal, Una Kula, P.E., Phoenix, Arizona

Stanley D. Lindsey, President, Stanley D. Lindsey and Associates, Ltd., Atlanta, Georgia

Richard L. Maskil, Structural Engineer, U.S. Army Corps of Engineers, Missouri River Division, Omaha, Nebraska

Lawrence D. Reaveley, Professor and Chair, Department of Civil Engineering, University of Utah, Salt Lake City

Andrei M. Reinhorn, Professor of Structural Engineering, State University of New York, Buffalo

Thomas A. Sabol, President, Englekirk and Sabol, Consulting Structural Engineers, Los Angeles, California



Roland L. Sharpe, President, Sharpe Consulting Structural Engineers, Los Altos, California

John G. Shipp, Manager, Design Services, EQE Engineering and Design, Irvine, California

Scott Stedman, Stedman and Dyson, San Diego, California

Diana Todd, Consultant, Silver Spring, Maryland

Nabih Youssef, Principal, Nabih Youssef and Associates, Los Angeles, California

### **Technical Subcommittee 3, FOUNDATIONS AND GEOTECHNICAL CONSIDERATIONS**

#### **Chair**

Edward Rinne, Senior Principal, Kleinfelder, Inc., Pleasanton, California

#### **Members**

C. B. Crouse, Associate, Dames and Moore, Seattle, Washington

Klaus Jacob, Senior Research Scientist, Lamont-Doherty Geological Observatory of Columbia University, Palisades, New York

Maurice S. Power, Principal Engineer, Geomatrix Consultants, San Francisco, California

Cetin Soydemir, Vice President, Haley and Aldrich, Inc., Cambridge, Massachusetts

Les Youd, Brigham Young University, Provo, Utah

#### **Corresponding Members**

Harish Chander, Civil/Structural Engineer, Office of Nuclear Safety Policy and Standards, Department of Energy, Germantown, Maryland

Ricardo Dobry, Rensselaer Polytechnic Institute, Civil and Environmental Engineering, Troy, New York

Richard Fallgren, Vice President, Myers, Nelson, Houghton, Inc., Lawndale, California

Robert A. Garbini, National Ready Mixed Concrete Association, Silver Spring, Maryland

Neil M. Hawkins, Head, Civil Engineering, University of Illinois, Urbana

Husein Hasan, Tennessee Valley Authority, Knoxville, Tennessee

William F. Marcuson, III, Director, Geotechnical Laboratory, U.S. Army Engineer Waterways Experiment Station, Vicksburg, Mississippi

Thomas O'Rourke, Professor, Civil and Environmental Engineering, Cornell University, Ithaca, New York

C. Mark Saunders, Vice President, Rutherford and Chekene, San Francisco, California

J. P. Singh, Geospectra, Pleasanton, California

Steven A. Wendland, Geotechnical Engineer, Black and Veatch, Overlook Park, Kansas

## **Technical Subcommittee 4, CONCRETE STRUCTURES**

### **Chair:**

W. Gene Corley, Vice President, Construction Technology Laboratories, Skokie, Illinois

### **Members:**

David R. Bonneville, Vice President, Degenkolb Engineers, San Francisco, California

James E. Carpenter, Bruce C. Olsen Consulting Engineers, Seattle, Washington

Ned M. Cleland, Vice President-Engineering, Shockey Industries, and President, Blue Ridge Design, Inc., Winchester, Virginia

S. K. Ghosh, Director, Engineering Services, Codes and Standards, Portland Cement Association, Skokie, Illinois

David P. Gustafson, Vice President, Engineering, Concrete Reinforcing Steel Institute, Schaumburg, Illinois

James R. Harris, President, J. R. Harris and Company, Denver, Colorado

Neil M. Hawkins, Head, Civil Engineering, University of Illinois, Urbana

H. S. Lew, Chief, Structures Division, Building and Fire Research Laboratory, National Institute of Standards, Gaithersburg, Maryland

Vilas S. Mujumdar, Chief, Office of Regulation Services, Division of State Architect, Sacramento, California

James K. Wight, Professor, Department of Civil and Environmental Engineering, University of Michigan, Ann Arbor

### **Corresponding Members:**

David E. Arndt, Structural Engineer, KPFF Consulting Engineers, Seattle, Washington

Catherine E. French, Associate Professor, University of Minnesota, Minneapolis, Minnesota

Robert A. Garbini, National Ready Mixed Concrete Association, Silver Spring, Maryland

Max A. Gregersen, Senior Structural Engineer, CEntry Constructors and Engineers, Salt Lake City, Utah

Lawrence G. Griffis, Senior Vice President, Walter P. Moore and Associates, Houston, Texas

Phillip J. Iverson, Technical Director, Precast/Prestressed Concrete Institute, Chicago, Illinois

Mark Scott Jokerst, Associate, Forell/Elsesser Engineers, Inc., San Francisco, California

Colin Kumabe, Structural Engineer, Department of Building and Safety, City of Los Angeles, California

Kevin Kurt McDonnell, Commission Secretary, Board of Building and Safety Commission, Los Angeles, California

Robert F. Mast, Berger/ABAM Engineers, Federal Way, Washington

Joseph J. Messersmith, Coordinating Manager, Regional Code Services, Portland Cement Association, Rockville, Virginia

Robert F. Moehle, Professor, Civil Engineering and Director, Earthquake Engineering Research Center, University of California, Richmond

Antonio Nanni, Associate Professor, Architecture and Engineering Department, Pennsylvania State University, University Park

Mark Oakford, Project Engineer, Structural Division, Seattle, Washington

Joe Peyton, Tennessee Valley Authority, Knoxville, Tennessee

Richard J. Phillips, Vice President/Chief Engineer, Hillman, Biddison and Loevenguth, Los Angeles, California

Clarkson W. Pinkham, President, S. B. Barnes Associates, Los Angeles, California

Nigel Priestley, Professor, Structural Engineering, University of San Diego, and Principal, SEQAD Consulting Engineers, La Jolla, California

Andrei M. Reinhorn, Professor of Structural Engineering, State University of New York, Buffalo

David A. Sheppard, D. A. Sheppard, Consulting Engineers, Sonoma, California

Mete A. Sozen, Kettlehut Distinguished Professor of Structural Engineering, Purdue University, West Lafayette, Indiana

Jacob Grossman, Rosenwasser-Grossman and Associates, New York, New York

## **Technical Subcommittee 5, MASONRY STRUCTURES**

### **Chair**

Daniel P. Abrams, Professor, Civil Engineer, University of Illinois, Urbana

### **Members**

J. Gregg Borchelt, Director of Engineering and Research, Brick Institute of America, Reston, Virginia

Mark B. Hogan, Vice President of Engineering, National Concrete Masonry Institute, Herndon, Virginia

John C. Kariotis, President, Kariotis and Associates, Structural Engineers, Inc., South Pasadena, California

Richard E. Klingner, Phil M. Ferguson Professor in Civil Engineering, University of Texas, Austin

Ronald L. Mayes, President, Dynamic Isolation Systems, Inc., Lafayette, California

Max L. Porter, Professor, Department of Civil Engineering, Iowa State University, Ames

Daniel Shapiro, Principal, SOH and Associates, Structural Engineers, San Francisco, California

John Tawresey, KPFF Consulting Engineers, Seattle, Washington

Terence A. Weigel, Associate Professor, Department of Civil Engineering, University of Louisville, Kentucky

### **Corresponding Members**

James E. Amrhein, Consultant, Masonry Institute of America, Los Angeles, California

Robert Beiner, Deputy Executive Director, International Masonry Institute, Washington, D.C.

Ramon Gilsanz, Gilsanz Murray Steficek, New York, New York

Robert Chittenden, Senior Structural Engineer, Division of the State Architect, Fair Oaks, California

John Chrysler, Executive Director, Masonry Institute of America, Los Angeles, California

Thomas M. Corcoran, Structural Engineer, Integrus Architecture, Seattle, Washington

Gary C. Hart, Hart Consultant Group, Santa Monica, California

Antonio Nanni, Associate Professor, Architectural Engineering Department, Pennsylvania State University, University Park

Frank K. H. Park, Construction Plan Review Supervisor, Gilford County Planning and Development, Greensboro, North Carolina

Joe Peyton, Tennessee Valley Authority, Knoxville, Tennessee

Arturo E. Schultz, Research Structural Engineer, Building and Fire Research Laboratory, National Institute of Standards and Technology, Gaithersburg, Maryland

Alan R. Scott, Vice President, EQE International, St. Louis, Missouri

David L. Tennebaum, President, Innis-Tennebaum Architects, Inc., San Diego, California

## **Technical Subcommittee 6, STEEL STRUCTURES**

### **Chair**

C. Mark Saunders, Vice President, Rutherford and Chekene, San Francisco, California

### **Members**

Larry G. Griffis, Senior Vice President, Walter P. Moore and Associates, Houston, Texas

John L. Gross, Research Structural Engineer, National Institute of Standards and Technology, Gaithersburg, Maryland

Robert D. Hanson, Federal Emergency Management Agency, Pasadena, California

Nestor R. Iwankiw, Vice President, Technology and Research, American Institute of Steel Construction, Chicago, Illinois

Harry W. Martin, Regional Director, Construction Codes and Standards, American Iron and Steel Institute, Auburn, California

Clarkson W. Pinkham, President, S. B. Barnes Associates, Los Angeles, California

Thomas A. Sabol, Englekirk and Sabol, Inc., Los Angeles, California

Walter E. Schultz, Research Engineer, Nucor Rand, Norfolk, Nebraska

W. Lee Shoemaker, Director of Research, Metal Building Manufacturers Association, Cleveland, Ohio

Kurt D. Swensson, Associate, Stanley D. Lindsey and Associates, Ltd., Atlanta, Georgia

Chia-Ming Uang, Assistant Professor, Division of Structural Engineering, University of California, San Diego

### **Corresponding Members:**

Atorod Azizinamini, Associate Professor, University of Nebraska, Lincoln

Victor Azzi, Consulting Engineer, The Rack Manufacturers Institute, Rye, New Hampshire

Richard M. Drake, Principal Structural Engineer, Fluor Daniel, Inc., Irvine, California

Mohamed Elgaaly, Professor of Structural Engineering, Drexel University, Philadelphia, Pennsylvania

John D. Gillengerten, Senior Program Manager, John A. Martin and Associates, Inc., Roseville, California

Maury Golovin, Director of Engineering, Ceco Building Systems, Columbus, Mississippi  
Max A. Gregersen, Senior Structural Engineer, CEntry Constructors and Engineers, Salt Lake City, Utah  
Richard E. Holguin, Chief of Building Bureau, Department of Building and Safety, City of Los Angeles, California  
David L. Houghton, Principal and General Partner, Myers, Nelson, Houghton, Inc., Lawndale, California  
Clifton "Skip" Hyder, Varco-Pruden Buildings, Memphis, Tennessee  
Der Wang Jan, Tennessee Valley Authority, Knoxville, Tennessee  
Stanley D. Lindsey, President, Stanley D. Lindsey and Associates, Ltd., Atlanta, Georgia  
Terry R. Lundeen, Principal, Coughlin Porter Lundeen, Inc., Seattle, Washington  
James O. Malley, Principal, Degenkolb Engineers, San Francisco, California  
Guy J.P. Nordenson, Guy Nordenson and Associates, New York, New York  
Clifford J. Ousley, Structural Consultant, Bethlehem Steel Corporation, Bethlehem, Pennsylvania  
Thomas Scarangelo, Thorton Tomasetti Engineers, New York, New York

## **Technical Subcommittee 7, WOOD STRUCTURES**

### **Chair**

J. Daniel Dolan, Department of Wood Science and Forest, Virginia Polytechnic Institute and State University, Blacksburg

### **Members**

Kenneth R. Andreason, Senior Engineer, American Plywood Association, Tacoma, Washington  
L. F. "Skip" Bush, Owner, L.F. Bush Consulting Structural Engineer, Tacoma, Washington  
Kelly Cobeen, Structural Engineer, GFDS Engineers, San Francisco, California  
Robert S. George, Robert S. George Architect, San Bruno, California  
Frank Park, Gilford County Planning and Development, Greensboro, North Carolina  
David P. Tyree, Regional Manager, American Forest and Paper Association, Colorado Springs, Colorado  
Edwin Zacher, Vice President, H. J. Brunnier Associates, San Francisco, California

### **Corresponding Members**

Allan E. Bessett, Principal, AHBL, Tacoma, Washington  
Kevin C. K. Cheung, Director, Engineering Support, Western Wood Products Association, Portland, Oregon  
Ted Christensen, Chief Structural Engineer, Wheeler and Gray Inc., Los Angeles, California  
John M. Coil, President, John Coil Associates, Inc., Tustin, California  
Robert F. Elliott, Construction Technology and Codes Specialist, National Association of Home Builders, Washington, D.C. (through June 1997)  
Robert F. Harder, Manager, West Los Angeles Office, Los Angeles Department of Building and Safety, California  
Der Wang Jan, Tennessee Valley Authority, Knoxville, Tennessee

Erol Karacabeyli, Professional Engineer, Wood Engineering Scientist, Forintek Canada Corporation, Vancouver, British Columbia, Canada

Lincoln Kwok Wai Lee, Structural Engineering Consultant, City of Los Angeles, Monterey Park, California

Rene W. Luft, Simpson Gumpertz and Heger, San Francisco, California

Jeffrey M. McIntyre, Structural Engineering Associate, Los Angeles Department of Building and Safety, California

Robert M. Powell, President and CEO, Powell, Mika/Burkett and Wong, Los Angeles, California

Ed Sutton, Construction, Codes & Standards Department, National Association of Home Builders, Washington, D.C. (since June 1997)

Victor L. Taugher, Owner, Taugher and Associates, Castro Valley, California

### **Technical Subcommittee 8, MECHANICAL/ELECTRICAL SYSTEMS AND BUILDING EQUIPMENT AND ARCHITECTURAL ELEMENTS**

#### **Chair**

Robert E. Bachman, Department Manager, Civil/Structural Engineering, Fluor Daniel, Inc., Irvine, California

#### **Members**

Leo Argiris, Ove Arup and Partners, New York, New York

Christopher Arnold, President, Building Systems Development, Inc., Palo Alto, California

Leo Bragagnolo, EQE International, San Francisco, California

Richard M. Drake, Principal Structural Engineer, Fluor Daniel, Inc., Irvine, California

Russell Fleming, Vice President of Engineering, National Fire Sprinkler Association, Patterson, New York

John D. Gillengerten, Senior Program Manager, John A. Martin and Associates, Inc., Roseville, California

John V. Loscheider, Principal, Loscheider Engineering Company, Renton, Washington

Gary McGavin, Architect, Tehachapi, California

Vilas Mujumdar, Chief, Division of State Architect, Sacramento, California

Brian C. Olson, National Park Service, Denver, Colorado

William W. Stewart, Stewart Schaberg/Architects, Clayton, Missouri

#### **Corresponding Members**

J. Marx Ayres, Ayres and Ezer Associates Consulting Engineers, Los Angeles, California

Victor Azzi, Consulting Engineer, The Rack Manufacturers Institute, Rye, New Hampshire

Eric Brown, Hillman, Biddison and Loevenguth, Los Angeles, California

Charles Ebbing, Carrier Corporation, Syracuse, New York

John L. Fisher, Architect/Engineer, Marysville, California

Edgar F. Glock, Jr., Executive Director, Masonry Institute of St. Louis, Richmond Heights, Missouri

Subhash C. Goel, Professor of Civil Engineering, University of Michigan, Ann Arbor

Husein Hasan , Tennessee Valley Authority, Knoxville, Tennessee  
Ronald W. Haupt, Pressure Piping Engineering Assocs., Inc., Foster City, California  
Gerald M. Herber, Boeing Commercial Airplanes, Bellevue, Washington  
Leonard Joseph, Thornton Tomasetti Engineers, New York, New York  
Pat Lama, Mason Industries, New York, New York  
Paul Meisel, Kinetics Noise Control, Dublin, Ohio  
Todd Noce, Mason Industries, Anaheim, California  
Guy J.P. Nordenson, Guy Nordenson and Associates, New York, New York  
Allan Porush, Dames and Moore, Los Angeles, California  
James Rearden, Sverdrup Facilities, Inc., St. Louis, Missouri  
Dan Robinson, M. W. Sausse and Co., Inc., Valencia, California  
Richard E. Schaffstall, Schaffstall Associates, Reston, Virginia  
Anshel J. Schiff, Stanford University, Los Altos, California  
Thomas Lee Smith, Director of Technology and Research, National Roofing Contractors Association, Rosemont, Illinois  
Larry Soong, Department of Civil Engineering, State University of New York, Buffalo  
William Staehlin, California - OSHPD, Sacramento, California  
Bob Vlick, Air Conditioning Co., Inc., Glendale, California  
Robert Waslewski, SMACNA, Chantilly, Virginia  
William Wilcox, Factory Mutual Research Corporation, Norwood, Massachusetts  
Richard Wollmershauser, Hilti, Inc., Tulsa, Oklahoma

**Ex-officioMember**

Harold Sprague, Structural Engineer, Black and Veatch, Overland Park, Kansas

**Observer**

Erdem Ural, Factory Mutual Research Corporation, Norwood, Massachusetts

## **Technical Subcommittee 9, QUALITY ASSURANCE**

### **Chair**

Charles A. Spitz, Architect-Planner-Code Consultant, West Long Branch, New Jersey

### **Members**

Susan Dowty, Senior Staff Engineer, International Conference of Building Officials, Whittier, California  
Warner Howe, Consulting Structural Engineer, Germantown, Tennessee  
Mark Kluver, Manager, Regional Code Services, San Ramon, California

Richard J. Phillips, Vice President/Chief Engineer, Hillman, Biddison and Loevenguth, Los Angeles, California

Tom Schlafly, American Institute of Steel Construction, Chicago, Illinois

Jim W. Sealy, Jim W. Sealy/Architect/Consultant, Dallas, Texas

### **Corresponding Members**

Robert F. Elliott, Construction Technology and Codes Specialist, National Association of Home Builders, Washington, D.C. (through June 1997)

Richard T. Kanemasu, President, Terracon Consultants Western, Inc., Denver, Colorado

Said Larbi-Cherif, Plan Check Engineer, Public Inspection Department, El Paso, Texas

Doreen Christian LaRoche, Civil Engineer, Engineering Branch, U.S. Department of Agriculture, Facilities Management Division, Washington Area Service Center, Washington, D.C.

John V. Loscheider, Principal, Loscheider Engineering Company, Renton, Washington

Ronald F. "Rawn" Nelson, Principal, Saunders/MNH, Costa Mesa, California

Rick Chandler, Department of Buildings, New York, New York

John R. "Jack" Prosek, Jr., Project Manager, Turner Construction Company, Palo Alto, California

Ed Sutton, Construction, Codes & Standards Department, National Association of Home Builders, Washington, D.C. (since June 1997)

## **Technical Subcommittee 10**

### **INTERFACE WITH CODES AND STANDARDS**

#### **Chair**

Susan Dowty, Senior Staff Engineer, Codes and Standards Department, International Conference of Building Officials, Whittier, California

#### **Members**

John Battles, Manager, Codes, Southern Building Code Congress, International, Birmingham, Alabama

Robert N. Chittenden, Code Engineer, Division of State Architect, Fair Oaks, California

Karl Deppe, Assistant Deputy Superintendent of Building, City of Los Angeles, California

Scott Humphreys, Staff Engineer, Building Officials and Code Administrators, International, Country Club Hills, Illinois (through March 1997)

Joseph J. Messersmith, Coordinating Manager, Regional Code Services, Portland Cement Association, Rockville, Virginia

Mark Nunn, Senior Building Codes Engineer, Brick Institute of America, Reston, Virginia

Douglas M. Smits, Certified Building Official/Director, Department of Public Service/Chief Building./Fire Official, City of Charleston, Charleston, South Carolina



Charles A. Spitz, Architect-Planner-Code Consultant, West Long Branch, New Jersey

David P. Tyree, American Forest and Paper Association, Colorado Springs, Colorado

Robert J. Wills, Jr., Regional Director, American Iron and Steel Institute, Birmingham, Alabama

### **Corresponding Members**

Harish Chander, Civil/Structural Engineer, Office of Nuclear Safety, Policy and Standards, U.S. Department of Energy, Germantown, Maryland

Rick D. Chandler, Deputy Borough Superintendent, New York City Department of Buildings, New York

Walter B. Grossman, Brookhaven National Laboratory, Upton, New York

Cynthia A. Hoover, Structural Building Inspector, Department of Construction and Land Use, City of Seattle, Seattle, Washington

Robert McClure, Building Officials and Code Administrators International, Inc., Country Club Hills, Illinois (beginning April 1997)

Brian Charles Olson, Safety Engineer, National Park Service, Denver, Colorado

Frank Park, Guilford County Planning and Development, Greensboro, North Carolina

Diana Todd, Consultant, Silver Spring, Maryland

## **Technical Subcommittee 11, COMPOSITE STEEL AND CONCRETE STRUCTURES**

### **Chair**

Gregory Deierlein, Associate Professor, School of Civil and Environmental Engineering, Cornell University, Ithaca, New York

### **Members**

Richard W. Furlong, Professor of Civil Engineering, University of Texas, Austin

Lawrence G. Griffis, Senior Vice President, Director of Structural Engineering, Walter P. Moore and Associates, Houston, Texas

Robert A. Halvorson, Principal, Halvorson and Kaye, Structural Engineers, PC, Chicago, Illinois

Roberto T. Leon, Professor, School of Civil and Environmental Engineering, Georgia Institute of Technology, Atlanta

James O. Malley, Principal, Degenkolb Engineers, San Francisco, California

Ivan M. Viest, Hellertown, Pennsylvania

### **Corresponding Members**

Atorod Azizinamini, Associate Professor, Civil Engineering Department, University of Nebraska, Lincoln

W. Gene Corley, Vice President, Construction Technology Laboratories, Skokie, Illinois

Grant Davis, Principal, KPFF Consulting Engineers, Portland, Oregon

Subhash Goel, Department of Civil Engineering, University of Michigan, Ann Arbor

Thomas Scarangelo, Thornton Tomasetti Engineers, New York, New York

Neil W. Hawkins, Head, Civil Engineering, University of Illinois, Urbana

Nestor Iwankiw, Vice President, Technology and Research, American Institute of Steel Construction, Chicago, Illinois

Manuel Morden, Senior Associate, Brandow and Johnston Associates, Los Angeles, California

Joe Peyton, Tennessee Valley Authority, Knoxville, Tennessee

Clarkson W. Pinkham, S.B. Barnes Associates, Los Angeles, California

James Ricles, Lehigh University, Bethlehem, Pennsylvania

Bahram M. Sharooz, Associate Professor, Department of Civil and Environmental Engineering, University of Cincinnati, Ohio

Kurt D. Swensson, Associate, Stanley D. Lindsey and Associates, Ltd, Atlanta, Georgia

Nabih Youssef, Principal, Nabih Youssef and Associates, Los Angeles, California

## **Technical Subcommittee 12, BASE ISOLATION AND ENERGY DISSIPATION**

### **Chair**

Charles Kircher, Principal, Charles Kircher and Associates, Consulting Engineers, Mountain View, California

### **Members**

Michael Constantinou, Professor, Department of Civil Engineering, State University of New York, Buffalo

Saif Hussain, Principal, Saif Hussain and Associates, Woodland Hills, California

Ronald L. Mayes, President, Dynamic Isolation Systems, Lafayette, California

Lawrence Reaveley, Professor and Chair, Civil Engineering Department, University of Utah, Salt Lake City

Roger E. Scholl, President, CounterQuake Corporation, Redwood City, California (deceased)

Andrew W. Taylor, Research Structural Engineer, Building and Fire Research Laboratory, National Institute of Standards and Technology, Gaithersburg, Maryland

Andrew Whittaker, Associate Director, Earthquake Engineering Research Center, University of California, Richmond

### **Corresponding Members**

Leo Argiris, Ove Arup and Partners, New York, New York

Jefferson W. Asher, Vice President, KPFF Consulting Engineers, Santa Monica, California

Finley A. Charney, President, Advanced Structural Concepts, Inc., Golden, Colorado

Yeuan Chou, Major Structures Plan Check Supervisor, Los Angeles Department of Building and Safety, California

John R. Gavan, Associate, KPFF Consulting Engineers, Santa Monica, California

Husein Hasan, Tennessee Valley Authority, Knoxville, Tennessee

Jean-Paul Pinelli, Assistant Professor, Civil Engineering, Florida Tech, Melbourne

Andrei M. Reinhorn, State University of New York, Buffalo

Tsu T. Soong, State University of New York, Buffalo

David B. Swanson, Project Engineer, Reid Middleton, Inc., Lynnwood, Washington

### **Technical Subcommittee 13, NONBUILDING STRUCTURES**

#### **Chair**

Harold Sprague, Structural Engineer, Black and Veatch, Overland Park, Kansas

#### **Members**

Clayton L. Clem, Manager, Structural and Foundation Engineering Department, Tennessee Valley Authority, Chattanooga, Tennessee

Gerald M. Herber, Bellevue, Washington

Frank J. Hsiu, Civil Structural Team Leader, Chevron Research and Technology Company, Richmond, California

Leon Kempner, Jr., Principal Transmission Civil and Mechanical Facilities Analysis Manager, Bonneville Power Administration, Portland, Oregon

Nicholas A. Legatos, Vice President, Preload Inc., Garden City, New York

#### **Corresponding Members**

Mark Anderson, Alyeska Pipeline Service Company, Anchorage, Alaska

Victor Azzi, Consulting Engineer, The Rack Manufacturers Institute, Rye, New Hampshire

Leo J. Bragagnolo, Associate Principal Engineer, EQE International, San Francisco, California

Ralph T. Eberts, Senior Project Manager, Black and Veatch, Los Angeles, California

Rulon Fronk, LADWP, Los Angeles, California

Warner Howe, Consulting Structural Engineer, Germantown, Tennessee

Der Wang Jan, Tennessee Valley Authority, Knoxville, Tennessee

Ed Matsuda, Senior Structural/Seismic Engineer, Pacific Gas and Electric Company, San Francisco, California

Stephen W. Meier, Chicago Bridge and Iron, Plainfield, Illinois

Dennis K. Ostrom, Consultant, Canyon County, California

Michael R. Simac, President and Principal Engineer, Earth Improvement Technologies, Cramerton, North Carolina

Bud Stacy, Walt Disney Imagineering, Glendale, California

Albert J. Tharnish, Black and Veatch, Lake Oswego, Oregon

#### **Ex-Officio Member**

Robert E. Bachman, Fluor Daniel, Inc., Irvine, California

### **TASK 3 ("PROJECT '97") MANAGEMENT COMMITTEE**

#### **Chair**

Allan R. Porush, Dames and Moore, Los Angeles, California

---

## **Members**

Clarence R. Allen, California Institute Inc., Pasadena, California

Glenn R. Bell, Simpson, Gumpertz and Heger, Inc., Arlington, Massachusetts

William T. Holmes, Vice President, Rutherford and Chekene, San Francisco, California

Robert Wesson, U.S. Geological Survey, Office of Earthquakes, Volcanoes and Engineering, Reston, Virginia

## **FEMA Representatives**

Michael Mahoney, Physical Scientist, FEMA, Washington, D.C.

Robert D. Hanson, FEMA, Pasadena, California

## **Seismic Design Procedure Group**

### **Chair**

R. Joe Hunt, Lockheed-Martin Energy Systems, Oak Ridge, Tennessee

Roger D. Borchardt, Office of Earthquakes, Volcanoes and Earthquakes, U.S. Geological Survey, Menlo Park, California

C. B. Crouse, Dames and Moore, Seattle, Washington

James R. Harris, J. R. Harris and Company, Denver, Colorado

Jeffrey K. Kimball, Engineering and Operations Support, U.S. Department of Energy, Germantown, Maryland

Charles A. Kircher, Principal, Charles Kircher and Associates, Mountain View, California

E. V. Leyendecker, Research Civil Engineer, U.S. Geological Survey, Denver, Colorado

Guy J.P. Nordenson, Guy Nordenson and Associates, New York, New York

Todd W. Perbix, Skilling Ward Magnusson Barkshire Inc., Seattle, Washington

Chris D. Poland, Degenkolb Engineers, San Francisco, California

Lawrence D. Reaveley, Civil Engineering Department, University of Utah, Salt Lake City

Thomas A. Sabol, Englekirk and Sabol, Inc., Los Angeles, California

Roland Sharpe, President, Sharpe Consulting Structural Engineers, Los Altos, California

John C. Theiss, Vice President, EQE - Theiss, St. Louis, Missouri

### **Nonvoting Members**

Loring Wyllie, Jr., Degenkolb Engineers, San Francisco, California

Ronald O. Hamburger, Vice President, EQE International, San Francisco, California

## **RESOURCE GROUP**

John R. Battles, Southern Building Code Congress, International, Birmingham, Alabama

David A. Bugni, Jacobs-Sirrine Engineers, Lake Oswego, Oregon (representing the Structural Engineers Association of Oregon)

Warner Howe, Germantown, Tennessee (representing the Center for Earthquake Research and Information of The University of Memphis)

Mehrdad Mahdiyar, Vortex Rock Consultants, Inc., Corona, California (representing the Southern California Earthquake Center)

Bijan Mohraz, National Institute of Standards and Technology, Building and Fire Research Laboratory, Gaithersburg, Maryland (representing the Applied Technology Council)

Robert McCluer, Manager, Codes, Building Officials and Code Administrators, International, Country Club Hills, Illinois

H. S. Lew, Chief, Structures Division, Building and Fire Research Laboratory, National Institute of Standards and Technology, Gaithersburg, Maryland (representing the Interagency Committee on Seismic Safety and Construction)

## **REPRESENTATIVES OF BSSC MEMBER ORGANIZATIONS AND THEIR ALTERNATES**

### **AFL-CIO Building and Construction Trades Department**

**Representative** Sandra Tillett, Acting Director, Safety and Health, AFL-CIO Building and Construction Trades Department, Washington, D.C.

**Alternate** Pete Stafford, Center to Protect Workers' Rights, Washington, D.C.

### **AISC Marketing, Inc.**

**Representative** Robert Pyle, AISC Marketing, Inc., Buena Park, California

**Alternate** None on record

### **American Concrete Institute**

**Representative** Arthur J. Mullkoff, Staff Engineer, American Concrete Institute, Farmington Hills, Michigan

**Alternate** Ward R. Malisch, Managing Director, Engineering, American Concrete Institute, Farmington Hills, Michigan

### **American Consulting Engineers Council**

**Representative** Roy G. Johnston, Structural Engineer, Brandow and Johnston Associates, Los Angeles, California

**Alternate** Edward Bajer, Director of Energy and Interprofessional, American Consulting Engineers Council, Washington, D.C.

### **American Forest and Paper Association**

**Representative** David P. Tyree, Regional Manager, American Forest and Paper Association, Colorado Springs, Colorado

**Alternate** Bradford K. Douglas, Director of Engineering, American Forest and Paper Association, Washington, D.C.

### **American Institute of Architects**

**Representative** William W. Stewart, Stewart Schaberg/Architects, Clayton, Missouri

**Alternate** Gabor Lorant, Gabor Lorant Architect, Inc., Phoenix, Arizona

**American Institute of Steel Construction**

**Representative** Nestor Iwankiw, American Institute of Steel Construction, Chicago, Illinois

**Alternate** None on record

**American Insurance Services Group, Inc.**

**Representative** John A. Mineo, Manager, Construction, American Insurance Services Group, Inc., New York, New York

**Alternate** Phillip Olmstead, Senior Technical Consultant, ITT Hartford Insurance Group, Hartford, Connecticut

**American Iron and Steel Institute**

**Representative** Harry W. Martin, Regional Director, American Iron and Steel Institute, Newcastle, California

**Alternate** None on record

**American Plywood Association**

**Representative** Kenneth R. Andreason, American Plywood Association, Tacoma, Washington

**Alternate** William A. Baker, Manager, Market Support Services, American Plywood Association, Tacoma, Washington

**American Society of Civil Engineers**

**Representative** John C. Theiss, Vice President, EQE - Theiss, St. Louis, Missouri

**Alternate** Ashvin Shah, American Society of Civil Engineers, Washington, D.C.

**American Society of Civil Engineers - Kansas City Chapter**

**Representative** Harold Sprague, Kansas City Chapter of ASCE, Overland, Missouri

**Alternate** Brad Vaughan, Kansas City Chapter of ASCE, Overland, Missouri

**American Society of Heating, Refrigerating and Air-Conditioning Engineers, Inc.**

**Representative** William Staehlin, Chairman, ASHRAE Task Group on Seismic Restraint Design, Sacramento, California

**Alternate** J. Richard Wright, Director of Technology, ASHRE, Atlanta, Georgia

**American Society of Mechanical Engineers**

**Representative** Evangelos Michalopoulos, Senior Engineer, Hartford Steam Boiler Inspection and Insurance Company, Codes and Standards Department, Hartford, Connecticut

**Alternate** Ronald W. Haupt, President, Pressure Piping Engineering Associates, Foster City, California

**American Welding Society**

**Representative** Hardy C. Campbell III, Senior Engineer, American Welding Society, Miami, Florida

**Alternate** Charles R. Fassinger, Managing Director, Technical Services, American Welding Society, Miami, Florida

**Applied Technology Council**

**Representative** Christopher Rojahn, Executive Director, Applied Technology Council, Redwood City, California

**Alternate** Charles N. Thornton, Chairman, The LZA Group, Inc., Thornton-Tomasetti, New York, New York

**Associated General Contractors of America**

**Representative** Jack Prosek, Project Manager, Turner Construction Company, Palo Alto, California

**Alternate** Christopher Monek, Associated General Contractors of America, Washington, D.C.

**Association of Engineering Geologists**

**Representative** Ellis Krinitzky, U.S. Army Corps of Engineers, Waterways Experiment Station, Vicksburg, Mississippi

**Alternate** Patrick J. Barosh, Patrick J. Barosh and Associates, Concord, Massachusetts

**Association of Major City Building Officials**

**Representative** Arthur J. Johnson, Jr., City of Los Angeles, Department of Building and Safety, Los Angeles, California

**Alternate** Karl Deppe, City of Los Angeles, Department of Building and Safety, Los Angeles, California

**Brick Institute of America**

**Representative** J. Gregg Borchelt, Director of Engineering and Research, Brick Institute of America, Reston, Virginia

**Alternate** Mark Nunn, Brick Institute of America, Reston, Virginia



### **Building Officials and Code Administrators International**

**Representative** David Wismer, Director of Planning and Code Development, Department of Licenses and Inspections, Philadelphia, Pennsylvania

**Alternate** Paul K. Heilstedt, Chief Executive Officer, Building Officials and Code Administrators International, Country Club Hills, Illinois

### **Building Owners and Managers Association International**

**Representative** Michael Jawer, BOMA International, Washington, D.C.

**Alternate** None on record

### **California Geotechnical Engineers Association**

**Representative** Alan Kropp, Alan Kropp and Associates, Berkeley, California

**Alternate** John A. Baker, Anderson Geotechnical Consultants, Roseville, California

### **California Seismic Safety Commission**

**Representative** Fred Turner, Staff Structural Engineer, California Seismic Safety Commission, Sacramento, California

**Alternate** None on record

### **Canadian National Committee on Earthquake Engineering**

**Representative** R. H. Devall, Chair, Canadian National Committee on Earthquake Engineering, Read Jones Christoffersen Ltd., Vancouver, British Columbia, Canada

**Alternate** D. A. Lutes, Canadian National Committee on Earthquake Engineering, National Research Council of Canada, Division of Research Building, Ottawa, Ontario, Canada

### **Concrete Masonry Association of California and Nevada**

**Representative** Stuart R. Beavers, Executive Director, Concrete Masonry Association of California and Nevada, Citrus Heights, California

**Alternate** Daniel Shapiro, Principal, SOH and Associates, Structural Engineers, San Francisco, California

### **Concrete Reinforcing Steel Institute**

**Representative** David P. Gustafson, Concrete Reinforcing Steel Institute, Schaumburg, Illinois

**Alternate** H. James Nevin, Western Regional Director, Concrete Reinforcing Steel Institute, Glendora, California

**Earthquake Engineering Research Institute**

**Representative** Joseph Nicoletti, URS Consultants, San Francisco, California

**Alternate** F. Robert Preece, Preece/Goudie and Associates, San Francisco, California

**Insulating Concrete Form Association**

**Representative** Dick Whitaker, President, Insulating Concrete Form Association, Glenview, Illinois

**Alternate** Dan Mistick, Vice President, Insulating Concrete Form Association, c/o Portland Cement Association, Skokie, Illinois

**Insurance Institute for Property Loss Reduction**

**Representative** Gregory L. F. Chiu, Engineer, Insurance Institute for Property Loss Reduction, Boston, Massachusetts

**Alternate** Karen Gahagan, Assistant Vice President for Information Services, Insurance Institute for Property Loss Reduction, Boston, Massachusetts

**Interagency Committee on Seismic Safety in Construction**

**Representative** Richard Wright, National Institute of Standards and Technology, Building and Fire Research Laboratory, Gaithersburg, Maryland

**Alternate** H. S. Lew, Chief, Structures Division, Building and Fire Research Laboratory, National Institute of Standards and Technology, Gaithersburg, Maryland

**International Conference of Building Officials**

**Representative** Rick Okawa, International Conference of Building Officials, Whittier, California

**Alternate** Susan M. Dowty, Senior Staff Engineer, International Conference of Building Officials, Whittier, California

**Masonry Institute of America**

**Representative** John Chrysler, Executive Director, Masonry Institute of America, Los Angeles, California

**Alternate** James E. Amrhein, Masonry Institute of America, Los Angeles, California

**Metal Building Manufacturers Association**

**Representative** W. Lee Shoemaker, Metal Building Manufacturers Association, Cleveland, Ohio

**Alternate** Joe N. Nunnery, AMCA Buildings Division, Memphis, Tennessee

### **National Association of Home Builders**

- Representative** Robert Elliott, Construction Technology and Codes Specialist, National Association of Home Builders, Washington, D.C. (through June 1997)  
Ed Sutton, Construction, Codes & Standards Department, National Association of Home Builders, Washington, D.C. (since June 1997)
- Alternate** None on record

### **National Concrete Masonry Association**

- Representative** Mark B. Hogan, Vice President of Engineering, National Concrete Masonry Association, Herndon, Virginia
- Alternate** Phillip J. Samblanet, Structural Engineer, National Concrete Masonry Association, Herndon, Virginia

### **National Conference of States on Building Codes and Standards**

- Representative** Richard T. Conrad, California Building Standards Commission, Sacramento, California
- Alternate** Robert C. Wible, Executive Director, National Conference of States on Bldg. Codes and Standards, Herndon, Virginia

### **National Council of Structural Engineers Associations**

- Representative** Howard Simpson, Simpson, Gumpertz and Heger, Arlington, Massachusetts
- Alternate** W. Gene Corley, Vice President, Construction Technology Laboratories, Skokie, Illinois

### **National Elevator Industry, Inc.**

- Representative** George A. Kappenhagen, Schindler Elevator Corporation, Morristown, New Jersey
- Alternate** None on record

### **National Fire Sprinkler Association, Inc.**

- Representative** Russell P. Fleming, Director, Engineering and Standards, National Fire Sprinkler Association, Patterson, New York
- Alternate** Kenneth E. Isman, Associate Director, Engineering and Standards, National Fire Sprinkler Association, Patterson, New York

### **National Institute of Building Sciences**

- Representative** Gerald H. Jones, Kansas City, Missouri
- Alternate** None on record

**National Ready Mixed Concrete Association**

**Representative** Robert A. Garbini, National Ready Mixed Concrete Association, Silver Spring, Maryland  
**Alternate** Jon I. Mullarky, First Vice President, National Ready Mixed Concrete Association, Silver Spring, Maryland

**Portland Cement Association**

**Representative** S. K. Ghosh, Director, Engineering Services, Codes and Standards, Portland Cement Association, Skokie, Illinois  
**Alternate** Joseph J. Messersmith, Portland Cement Association, Rockville, Virginia

**Precast/Prestressed Concrete Institute**

**Representative** Phillip J. Iverson, Technical Director, Precast/Prestressed Concrete Institute, Chicago, Illinois  
**Alternate** David A. Sheppard, D.A. Sheppard Consulting Structural Engineer, Inc., Sonoma, California

**Rack Manufacturers Institute**

**Representative** Victor Azzi, Rack Manufacturers Institute, Rye, New Hampshire  
**Alternate** John Nofsinger, Managing Director, Rack Manufacturers Institute, Charlotte, North Carolina

**Southern Building Code Congress International**

**Representative** John Battles, Manager/Codes, Southern Building Code Congress, International, Birmingham, Alabama  
**Alternate** T. Eric Stafford, E.I.T., Southern Building Code Congress International, Birmingham, Alabama

**Steel Deck Institute**

**Representative** Bernard E. Cromi, Managing Director, Steel Deck Institute, Canton, Ohio  
**Alternate** Richard B. Heagler, Nicholas J. Bouras Inc., Summit, New Jersey

**Structural Engineers Association of Arizona**

**Representative** Robert Stanley, Structural Engineers Association of Arizona, Scottsdale, Arizona  
**Alternate** None on record

**Structural Engineers Association of California**

**Representative** Allan R. Porush, Dames and Moore, Los Angeles, California

**Alternate** Thomas Wosser, Degenkolb Engineers, San Francisco, California

**Structural Engineers Association of Central California**

**Representative** Robert N. Chittenden, Structural Engineers Association of Central California, c/o Division of State Architect, Fair Oaks, California

**Alternate** Tom H. Hale, Retired, Cole, Yee, Schubert and Associates Retired, Sacramento, California

**Structural Engineers Association of Colorado**

**Representative** James R. Harris, President, J. R. Harris and Company, Denver, Colorado

**Alternate** Robert B. Hunnes, President, JVA, Incorporated, Boulder, Colorado

**Structural Engineers Association of Illinois**

**Representative** W. Gene Corley, Vice President, Construction Technology Laboratories, Skokie, Illinois

**Alternate** None on record

**Structural Engineers Association of Northern California**

**Representative** Ronald F. Middlebrook, S.E., Principal, Middlebrook + Louis, San Francisco, California

**Alternate** Edwin G. Zacher, H. J. Brunnier Associates, San Francisco, California

**Structural Engineers Association of Oregon**

**Representative** Joseph C. Gehlen, Kramer Gehlen Associates, Inc., Vancouver, Washington

**Alternate** Grant L. Davis, Structural Engineers Association of Oregon, c/o KPFF Consulting Engineers, Portland, Oregon

**Structural Engineers Association of Southern California**

**Representative** Saif Hussain, Principal, Saif Hussain and Associates, Woodland Hills, California

**Alternate** None on record

**Structural Engineers Association of San Diego**

**Representative** Ali Sadre, Structural Engineers Association of San Diego, c/o ESGIL Corporation, San Diego, California

**Alternate** Carl Schulze, San Diego, California

**Structural Engineers Association of Utah**

**Representative** Lawrence D. Reaveley, Civil Engineering Department, University of Utah, Salt Lake City  
**Alternate** Newland Malmquist, Structural Engineers Association of Utah, West Valley City, Utah

**Structural Engineers Association of Washington**

**Representative** James Carpenter, Bruce Olsen Consulting Engineer, Seattle, Washington  
**Alternate** Bruce C. Olsen, Bruce Olsen Consulting Engineer, Seattle, Washington

**The Masonry Society**

**Representative** John Kariotis, President, Kariotis and Associates, Structural Engineers, Inc., South Pasadena, California  
**Alternate** None on record

**Western States Clay Products Association**

**Representative** Donald A. Wakefield, Western States Clay Products Association, Sandy, Utah  
**Alternate** None on record

**Western States Council of Structural Engineers Association**

**Representative** Roger McGarrigle, Western States Council of Structural Engineers Association, Portland, Oregon  
**Alternate** William T. Rafferty, Western States Council of Structural Engineers Association, c/o Structural Design North, Spokane, Washington

**Wire Reinforcement Institute, Inc.**

**Representative** Roy H. Reiterman, Technical Director, Wire Reinforcement Institute, Inc., Findlay, Ohio  
**Alternate** Robert C. Richardson, Consultant, Wire Reinforcement Institute, Inc., Sun Lakes, Arizona

## **REPRESENTATIVES OF BSSC AFFILIATE MEMBER ORGANIZATIONS AND THEIR ALTERNATES**

### **Bay Area Structural, Inc.**

**Representative** David Benaroya Helfant, President/RMO, Bay Area Structural, Inc., Berkeley, California

### **Building Technology Inc.**

**Representative** David R. Hattis, President, Building Technology Inc., Silver Spring, Maryland

### **General Reinsurance Corporation**

**Representative** Cynthia L. Bordelon, Assistant Vice President, General Reinsurance Corporation, Chicago, Illinois

### **Permanent Commission for Structural Safety of Buildings**

**Representative** Arnaldo Gutierrez R., Civil Engineer/Chairman, Permanent Commission for Structural Safety of Buildings, Miami, FL

**Alternate** Joaquin Marin, Civil Engineer, Executive Director, Permanent Commission for Structural Safety of Buildings, Caracas, Venezuela

### **Southern California Gas Company**

**Representative** Manuel J. Parra, Director, Model Codes and Standards, Southern California Gas Company, Los Angeles, California

### **Steel Joist Institute**

**Representative** R. Donald Murphy, Managing Director, Steel Joist Institute, Myrtle Beach, South Carolina

### **Westinghouse Electric Corporation**

**Representative** William S. Lapay, Advisory Engineer, Westinghouse Electric Corporation, Export, Pennsylvania

### **Steven Winter Associates, Inc.**

**Representative** Steven Winter, President, Steven Winter Associates, Inc., Norwalk, Connecticut

### **U.S. Postal Service**

**Representative** Les L. Hegyi, H and H Group Inc., McLean, Virginia

